

WSM

WORKSHOP MANUAL
DIESEL ENGINE

SM-E2B SERIES

Kubota

TO THE READER

This Workshop Manual has been prepared to provide servicing personnel with information on the mechanism, service and maintenance of SM-E2B series. It is divided into three parts, "General", "Mechanism" and "Servicing".

■ General

Information on the engine identification, the general precautions, maintenance check list, check and maintenance and special tools are described.

■ Mechanism

Information on the construction and function are included. This part should be understood before proceeding with troubleshooting, disassembling and servicing.

Refer to Diesel Engine Mechanism Workshop Manual (Code No. 9Y021-01870) for the one which has not been described to this workshop manual.

■ Servicing

Information on the troubleshooting, servicing specification lists, tightening torque, checking and adjusting, disassembling and assembling, and servicing which cover procedures, precautions, factory specifications and allowable limits.

All information illustrations and specifications contained in this manual are based on the latest product information available at the time of publication.

The right is reserved to make changes in all information at any time without notice.

Due to covering many models of this manual, information or picture being used have not been specified as one model.

November 2004

© KUBOTA Corporation 2004



SAFETY FIRST

This symbol, the industry's "Safety Alert Symbol", is used throughout this manual and on labels on the machine itself to warn of the possibility of personal injury. Read these instructions carefully.

It is essential that you read the instructions and safety regulations before you attempt to repair or use this unit.



DANGER

: Indicates an imminently hazardous situation which, if not avoided, will result in death or serious injury.



WARNING

: Indicates a potentially hazardous situation which, if not avoided, could result in death or serious injury.



CAUTION

: Indicates a potentially hazardous situation which, if not avoided, may result in minor or moderate injury.



IMPORTANT

: Indicates that equipment or property damage could result if instructions are not followed.



NOTE

: Gives helpful information.

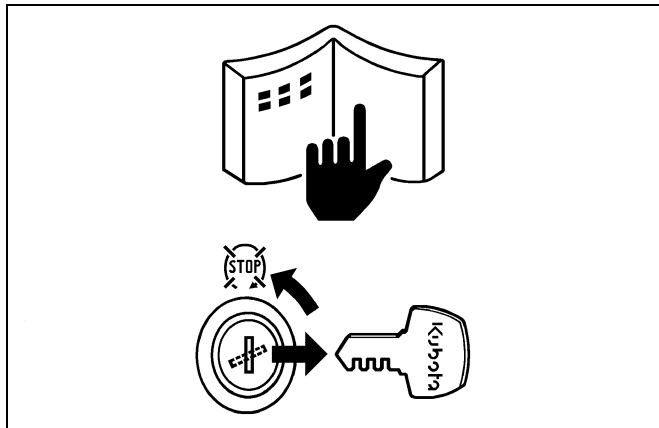

BEFORE SERVICING AND REPAIRING

- Read all instructions and safety instructions in this manual and on your engine safety decals.
- Clean the work area and engine.
- Park the machine on a firm and level ground.
- Allow the engine to cool before proceeding.
- Stop the engine, and remove the key.
- Disconnect the battery negative cable.
- Hang a "**DO NOT OPERATE**" tag in operator station.

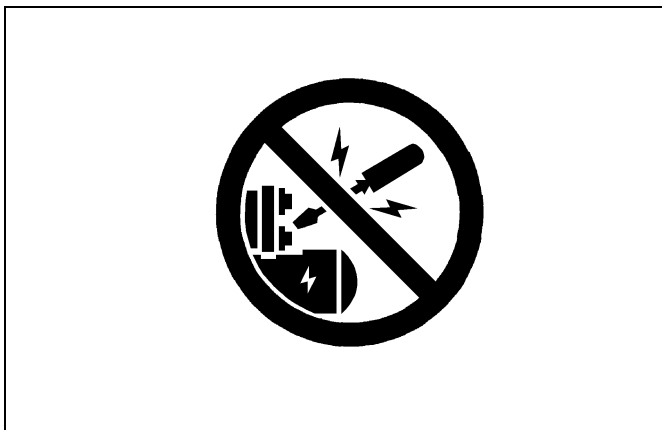

SAFETY STARTING

- Do not start the engine by shorting across starter terminals or bypassing the safety start switch.
- Unauthorized modifications to the engine may impair the function and / or safety and affect engine life.

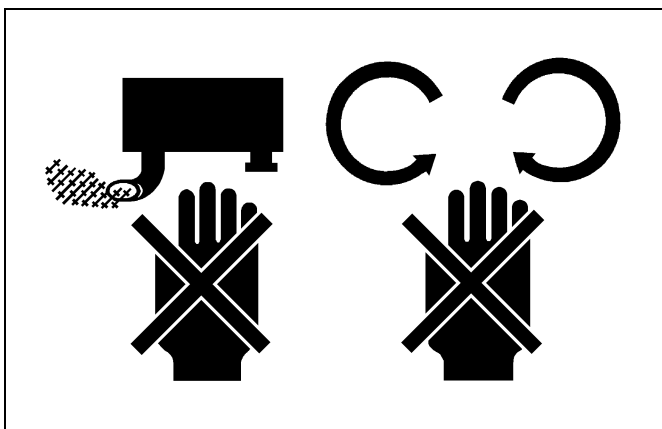

SAFETY WORKING

- Do not work on the machine while under the influence of alcohol, medication, or other substances or while fatigued.
- Wear close fitting clothing and safety equipment appropriate to the job.
- Use tools appropriate to the work. Makeshift tools, parts, and procedures are not recommended.
- When servicing is performed together by two or more persons, take care to perform all work safely.
- Do not touch the rotating or hot parts while the engine is running.
- Never remove the radiator cap while the engine is running, or immediately after stopping. Otherwise, hot water will spout out from radiator. Only remove radiator cap when cool enough to touch with bare hands. Slowly loosen the cap to first stop to relieve pressure before removing completely.
- Escaping fluid (fuel or hydraulic oil) under pressure can penetrate the skin causing serious injury. Relieve pressure before disconnecting hydraulic or fuel lines. Tighten all connections before applying pressure.
- Wear a suitable hearing protective device such as earmuffs or earplugs to protect against objectionable or uncomfortable loud noises.

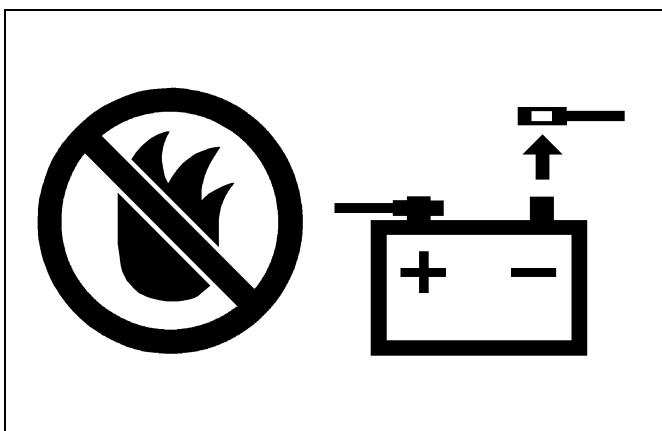
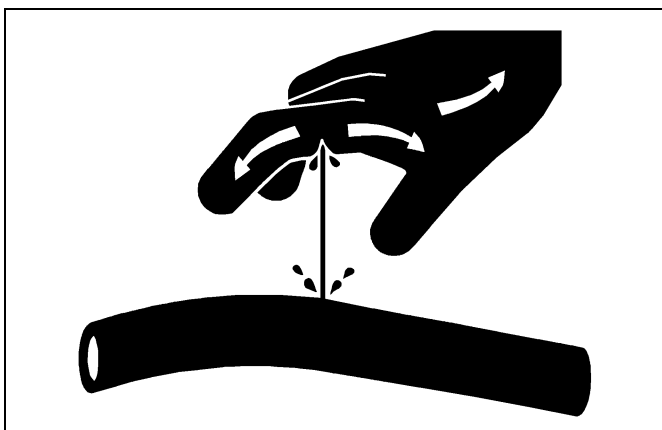

AVOID FIRES

- Fuel is extremely flammable and explosive under certain conditions. Do not smoke or allow flames or sparks in your working area.
- To avoid sparks from an accidental short circuit, always disconnect the battery negative cable first and connect it last.
- Battery gas can explode. Keep sparks and open flame away from the top of battery, especially when charging the battery.
- Make sure that no fuel has been spilled on the engine.

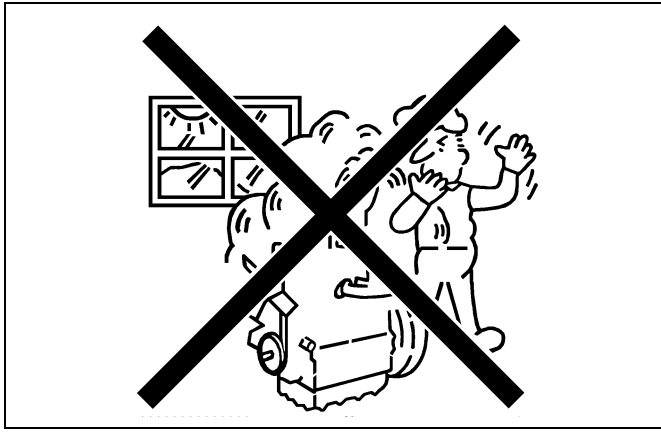

VENTILATE WORK AREA

- If the engine must be running to do some work, make sure the area is well ventilated. Never run the engine in a closed area. The exhaust gas contains poisonous carbon monoxide.

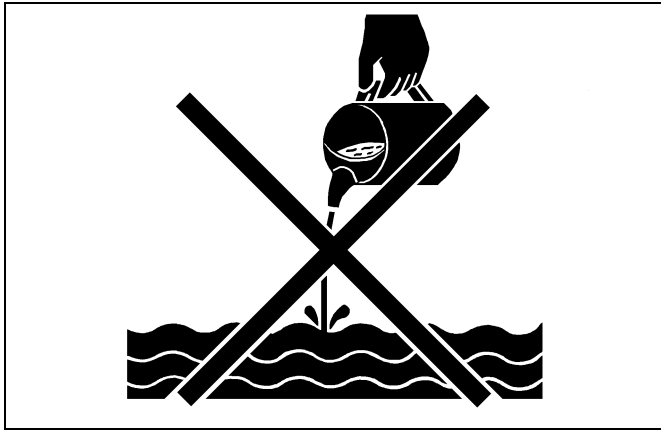

DISPOSE OF FLUIDS PROPERLY

- Do not pour fluids into the ground, down a drain, or into a stream, pond, or lake. Observe relevant environmental protection regulations when disposing of oil, fuel, coolant, electrolyte and other harmful waste.

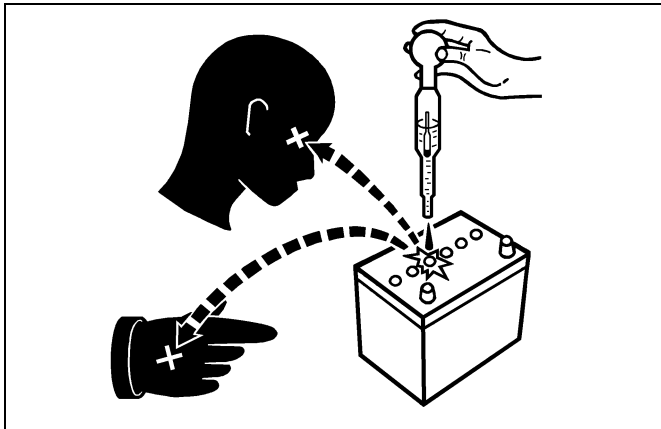

PREVENT ACID BURNS

- Sulfuric acid in battery electrolyte is poisonous. It is strong enough to burn skin, clothing and cause blindness if splashed into eyes. Keep electrolyte away from eyes, hands and clothing. If you spill electrolyte on yourself, flush with water, and get medical attention immediately.

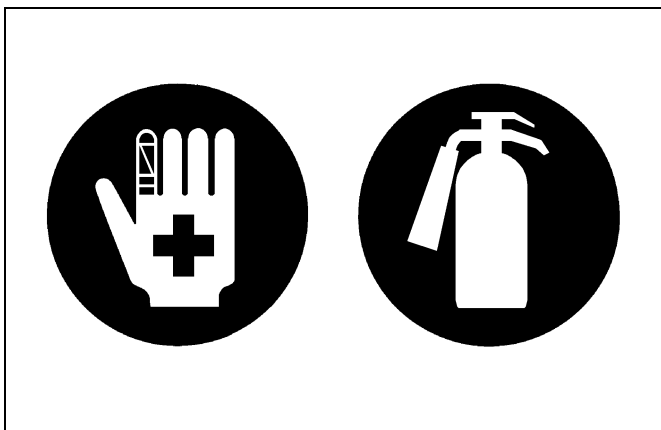

PREPARE FOR EMERGENCIES

- Keep a first aid kit and fire extinguisher handy at all times.
- Keep emergency numbers for doctors, ambulance service, hospital and fire department near your telephone.

SPECIFICATIONS

Model	Z482-E2B		Z602-E2B	
Number of Cylinders	2			
Type	Vertical, Water-cooled, 4 cycle IDI diesel engine			
Bore × Stroke	mm (in.)	67 × 68 (2.64 × 2.68)	72 × 73.6 (2.83 × 2.90)	
Total Displacement	cm ³ (cu.in.)	479 (29.23)	599 (36.55)	
ISO Net Continuous kW/min ⁻¹ (rpm) (HP/min ⁻¹ (rpm))		8.1 / 3600 (10.9 / 3600)	8.8 / 3200 (11.8 / 3200)	10.1 / 3600 (13.5 / 3600)
ISO / SAE Net Intermittent kW/min ⁻¹ (rpm) (HP/min ⁻¹ (rpm))		9.3 / 3600 (12.5 / 3600)	10.1 / 3200 (13.5 / 3200)	11.6 / 3600 (15.5 / 3600)
SAE Gross Intermittent kW/min ⁻¹ (rpm) (HP/min ⁻¹ (rpm))		9.9 / 3600 (13.3 / 3600)	10.8 / 3200 (14.5 / 3200)	12.5 / 3600 (16.8 / 3600)
Maximum Bare Speed	(min ⁻¹ (rpm))	3800	3450	3800
Minimum Bare Idling Speed	(min ⁻¹ (rpm))	900 to 1000		
Combustion Chamber	Spherical type (E-TVCS)			
Fuel Injection Pump	Bosch MD type mini pump			
Governor	All speed mechanical governor			
Direction of Rotation	Counter-clockwise (viewed from flywheel side)			
Injection Nozzle	Bosch "Throttle" type			
Injection Timing		0.35 rad (20 °) before T.D.C.	0.31 rad (18 °) before T.D.C.	0.35 rad (20 °) before T.D.C.
Firing Order	1-2			
Injection Pressure	13.73 MPa (140 kgf/cm ² , 1991 psi)			
Compression Ratio		23.5 : 1	24 : 1	
Lubricating System	Forced lubrication by trochoid pump			
Oil Pressure Indicating	Electrical type switch			
Lubricating Filter	Full flow paper filter (Cartridge type)			
Cooling System	Pressurized radiator, forced circulation with water pump (not included in the basic engine)			
Starting System	Electric Starting with Starter			
Starting Motor		12 V, 0.8 kW	12 V, 1.0 kW	
Starting Support Device	By glow plug in combustion chamber			
Battery		12 V, 28 AH equivalent	12 V, 36 AH equivalent	
Charging Alternator		12 V, 150 W	12 V, 480 W	
Fuel	Diesel Fuel No.2-D (ASTM D975)			
Lubricating Oil	Class CF lubricating oil as per API classification is recommended. If this class of lubricating oil is not available, preferably use Class CD or CE lubricating oil. For details on recommended lubricating oils, see page G-5, 8.			
Lubricating Oil Capacity	Oil Pan Depth 101 mm (3.98 in.)	2.1 L (0.55 U.S.gals)	2.5 L (0.66 U.S.gals)	
	Oil Pan Depth 121 mm (4.76 in.)	2.5 L (0.66 U.S.gals)	-	
Weight (Dry)	kg (lbs)	53.1 (117.1)	57.0 (125.7)	

* The specification described above is of the standard engine of each model.

* Conversion Formula : HP = 0.746 kW, PS = 0.7355 kW

W10336300

Model	D662-E2B		D722-E2B	
Number of Cylinders	3			
Type	Vertical, Water-cooled, 4 cycle IDI diesel engine			
Bore × Stroke	mm (in.)	64 × 68 (2.52 × 2.68)		67 × 68 (2.64 × 2.68)
Total Displacement	cm ³ (cu.in.)	656 (40.03)		719 (43.88)
ISO Net Continuous	kW/min ⁻¹ (rpm) (HP/min ⁻¹ (rpm))	11.2 / 3600 (15.0 / 3600)		12.2 / 3600 (16.4 / 3600)
ISO / SAE Net Intermittent	kW/min ⁻¹ (rpm) (HP/min ⁻¹ (rpm))	12.9 / 3600 (17.3 / 3600)		14.0 / 3600 (18.8 / 3600)
SAE Gross Intermittent	kW/min ⁻¹ (rpm) (HP/min ⁻¹ (rpm))	14.3 / 3600 (19.2 / 3600)		14.9 / 3600 (20.0 / 3600)
Maximum Bare Speed	(min ⁻¹ (rpm))	3800		
Minimum Bare Idling Speed	(min ⁻¹ (rpm))	900 to 1000		
Combustion Chamber	Spherical type (E-TVCS)			
Fuel Injection Pump	Bosch MD type mini pump			
Governor	All speed mechanical governor			
Direction of Rotation	Counter-clockwise (viewed from flywheel side)			
Injection Nozzle	Bosch "Throttle" type			
Injection Timing	0.35 rad (20 °) before T.D.C.			
Firing Order	1-2-3			
Injection Pressure	13.73 MPa (140 kgf/cm ² , 1991 psi)			
Compression Ratio	23 : 1		23.5 : 1	
Lubricating System	Forced lubrication by trochoid pump			
Oil Pressure Indicating	Electrical type switch			
Lubricating Filter	Full flow paper filter (Cartridge type)			
Cooling System	Pressurized radiator, forced circulation with water pump (not included in the basic engine)			
Starting System	Electric Starting with Starter			
Starting Motor	12 V, 0.8 kW			
Starting Support Device	By glow plug in combustion chamber			
Battery	12 V, 36 AH equivalent			
Charging Alternator	12 V, 150 W			
Fuel	Diesel Fuel No.2-D (ASTM D975)			
Lubricating Oil	Class CF lubricating oil as per API classification is recommended. If this class of lubricating oil is not available, preferably use Class CD or CE lubricating oil. For details on recommended lubricating oils, see page G-5, 8.			
Lubricating Oil Capacity	Oil Pan Depth 101 mm (3.98 in.)	3.2 L (0.85 U.S.gals)		
	Oil Pan Depth 121 mm (4.76 in.)	3.8 L (1.00 U.S.gals)		
Weight (Dry)	kg (lbs)	63.7 (140.4)		63.1 (139.1)

* The specification described above is of the standard engine of each model.

* Conversion Formula : HP = 0.746 kW, PS = 0.7355 kW

W10304910

Model	D782-E2B		D902-E2B	
Number of Cylinders	3			
Type	Vertical, Water-cooled, 4 cycle IDI diesel engine			
Bore × Stroke	mm (in.)	67 × 73.6 (2.64 × 2.90)	72 × 73.6 (2.83 × 2.90)	
Total Displacement	cm ³ (cu.in.)	778 (47.48)	898 (54.80)	
ISO Net Continuous kW/min ⁻¹ (rpm) (HP/min ⁻¹ (rpm))		11.7 / 3200 (15.7 / 3200)	13.4 / 3200 (18.0 / 3200)	15.2 / 3600 (20.4 / 3600)
ISO / SAE Net Intermittent kW/min ⁻¹ (rpm) (HP/min ⁻¹ (rpm))		13.5 / 3200 (18.1 / 3200)	15.4 / 3200 (20.6 / 3200)	17.5 / 3600 (23.5 / 3600)
SAE Gross Intermittent kW/min ⁻¹ (rpm) (HP/min ⁻¹ (rpm))		14.1 / 3200 (18.9 / 3200)	16.1 / 3200 (21.6 / 3200)	18.5 / 3600 (24.8 / 3600)
Maximum Bare Speed	(min ⁻¹ (rpm))	3450		3800
Minimum Bare Idling Speed	(min ⁻¹ (rpm))	900 to 1000		
Combustion Chamber	Spherical type (E-TVCS)			
Fuel Injection Pump	Bosch MD type mini pump			
Governor	All speed mechanical governor			
Direction of Rotation	Counter-clockwise (viewed from flywheel side)			
Injection Nozzle	Bosch "Throttle" type			
Injection Timing		0.30 rad (17 °) before T.D.C.	0.31 rad (18 °) before T.D.C.	0.35 rad (20 °) before T.D.C.
Firing Order	1-2-3			
Injection Pressure	13.73 MPa (140 kgf/cm ² , 1991 psi)			
Compression Ratio	24 : 1			
Lubricating System	Forced lubrication by trochoid pump			
Oil Pressure Indicating	Electrical type switch			
Lubricating Filter	Full flow paper filter (Cartridge type)			
Cooling System	Pressurized radiator, forced circulation with water pump (not included in the basic engine)			
Starting System	Electric Starting with Starter			
Starting Motor		12 V, 1.0 kW	12 V, 1.2 kW	
Starting Support Device	By glow plug in combustion chamber			
Battery		12 V, 36 AH equivalent	12 V, 52 AH equivalent	
Charging Alternator		12 V, 150 W	12 V, 480 W	
Fuel	Diesel Fuel No.2-D (ASTM D975)			
Lubricating Oil	Class CF lubricating oil as per API classification is recommended. If this class of lubricating oil is not available, preferably use Class CD or CE lubricating oil. For details on recommended lubricating oils, see page G-5, 8.			
Lubricating Oil Capacity	Oil Pan Depth 101 mm (3.98 in.)	–	3.7 L (0.98 U.S.gals)	
	Oil Pan Depth 121 mm (4.76 in.)	3.6 L (0.95 U.S.gals)	–	
Weight (Dry)	kg (lbs)	63.5 (139.7)	72.0 (158.7)	

* The specification described above is of the standard engine of each model.

* Conversion Formula : HP = 0.746 kW, PS = 0.7355 kW

W10321290

PERFORMANCE CURVES

■ Z482-E2B

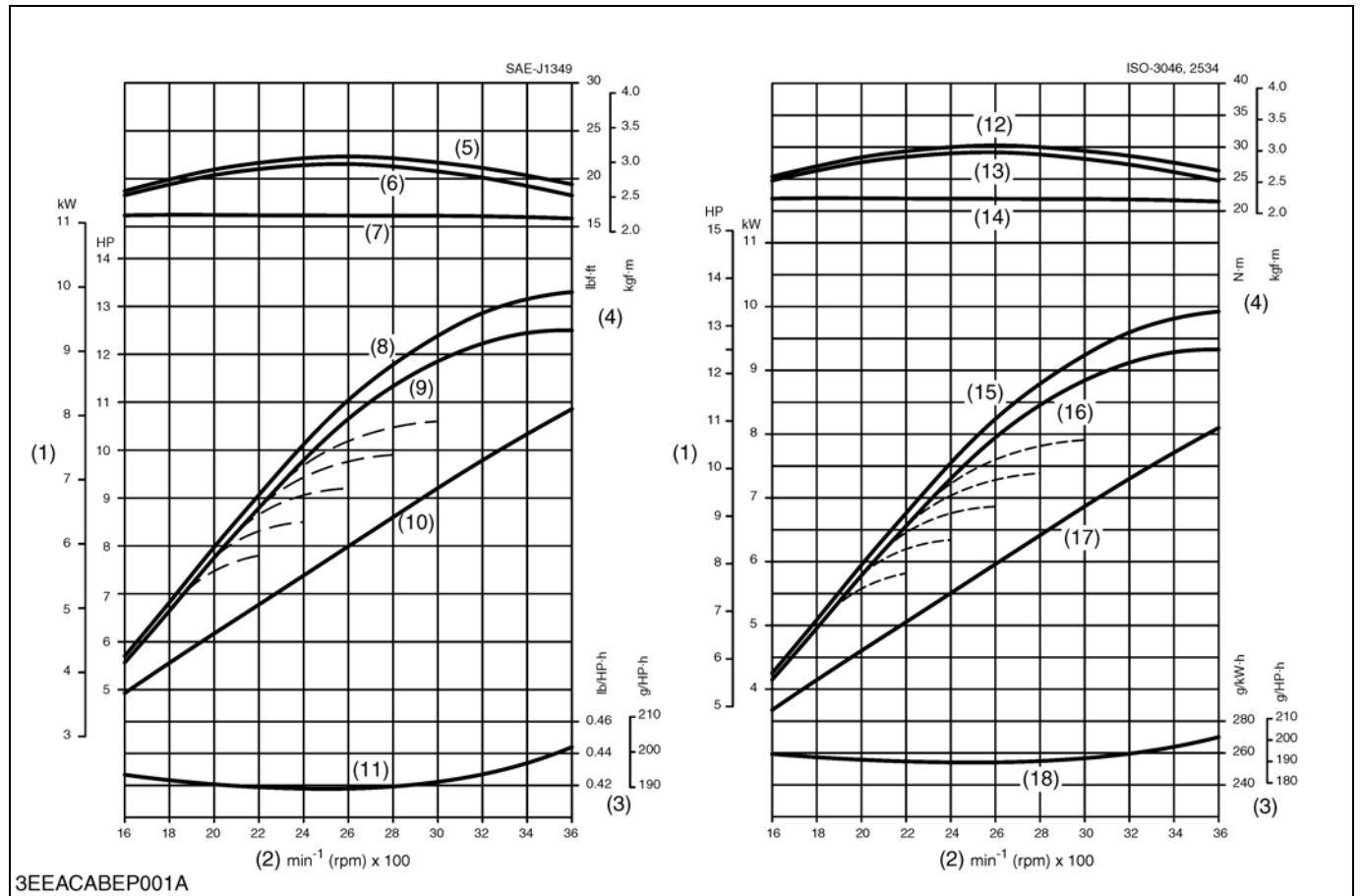

3EEACABEP001A

- | | | | |
|------------------------------|------------------------------|-------------------------------|------------------------|
| (1) Brake Horsepower | (6) Net Intermitent Torque | (11) Net Intermitent B.S.F.C. | (15) Gross B.H.P. |
| (2) Engine Speed | (7) Net Continuous Torque | (12) Gross Torque | (16) Overload B.H.P. |
| (3) B.S.F.C. | (8) Gross Intermitent B.H.P. | (13) Overload Torque | (17) Continuous B.H.P. |
| (4) Torque | (9) Net Intermitent B.H.P. | (14) Continuous Torque | (18) Overload B.S.F.C. |
| (5) Gross Intermitent Torque | (10) Net Continuous B.H.P. | | |

■ Z602-E2B (3200 min⁻¹ (rpm) spec.)

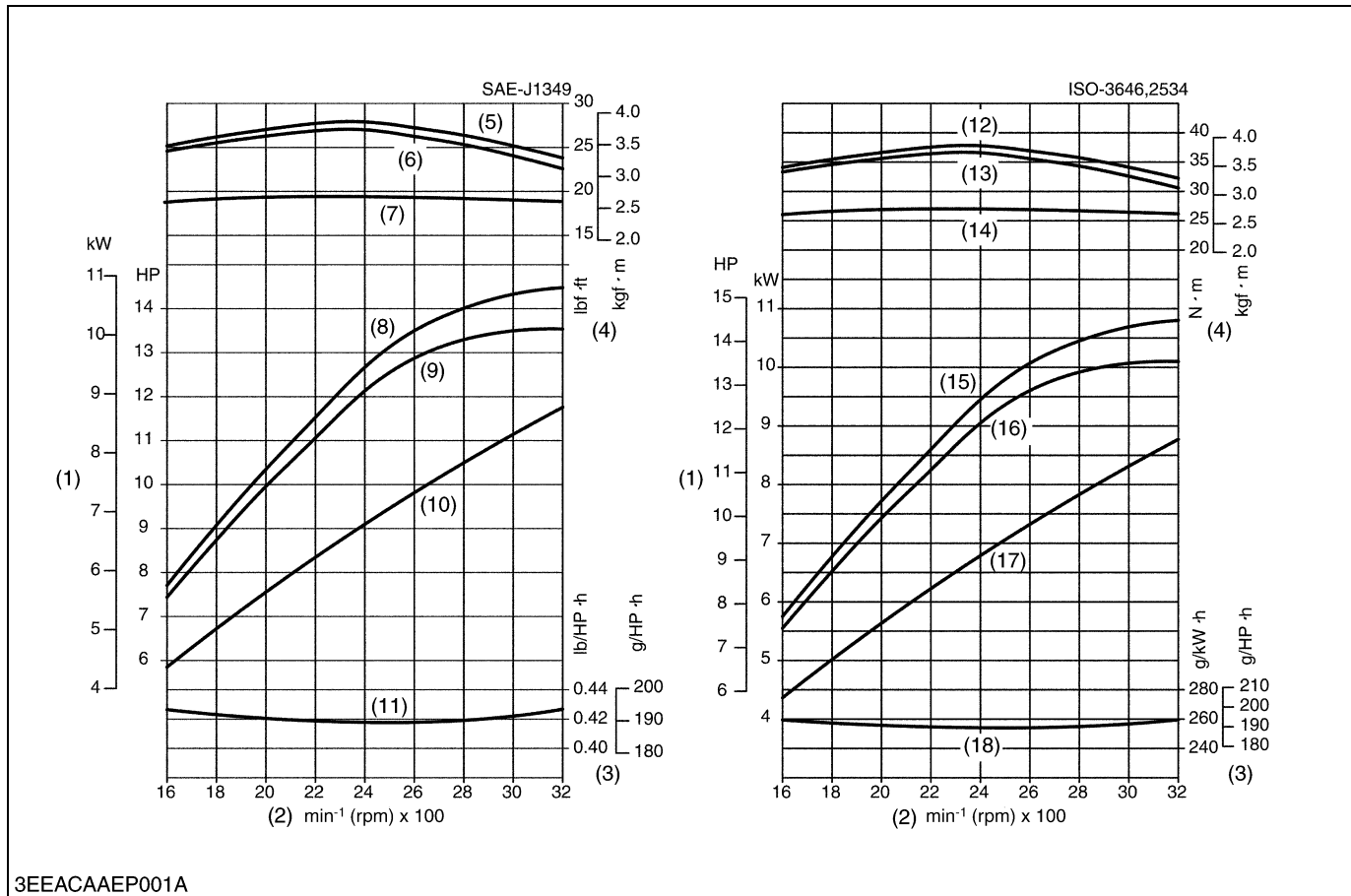

3EEACAAEP001A

- | | | | |
|-------------------------------|-------------------------------|--------------------------------|------------------------|
| (1) Brake Horsepower | (6) Net Intermittent Torque | (11) Net Intermittent B.S.F.C. | (15) Gross B.H.P. |
| (2) Engine Speed | (7) Net Continuous Torque | (12) Gross Torque | (16) Overload B.H.P. |
| (3) B.S.F.C. | (8) Gross Intermittent B.H.P. | (13) Overload Torque | (17) Continuous B.H.P. |
| (4) Torque | (9) Net Intermittent B.H.P. | (14) Continuous Torque | (18) Overload B.S.F.C. |
| (5) Gross Intermittent Torque | (10) Net Continuous B.H.P. | | |

■ Z602-E2B (3600 min⁻¹ (rpm) spec.)

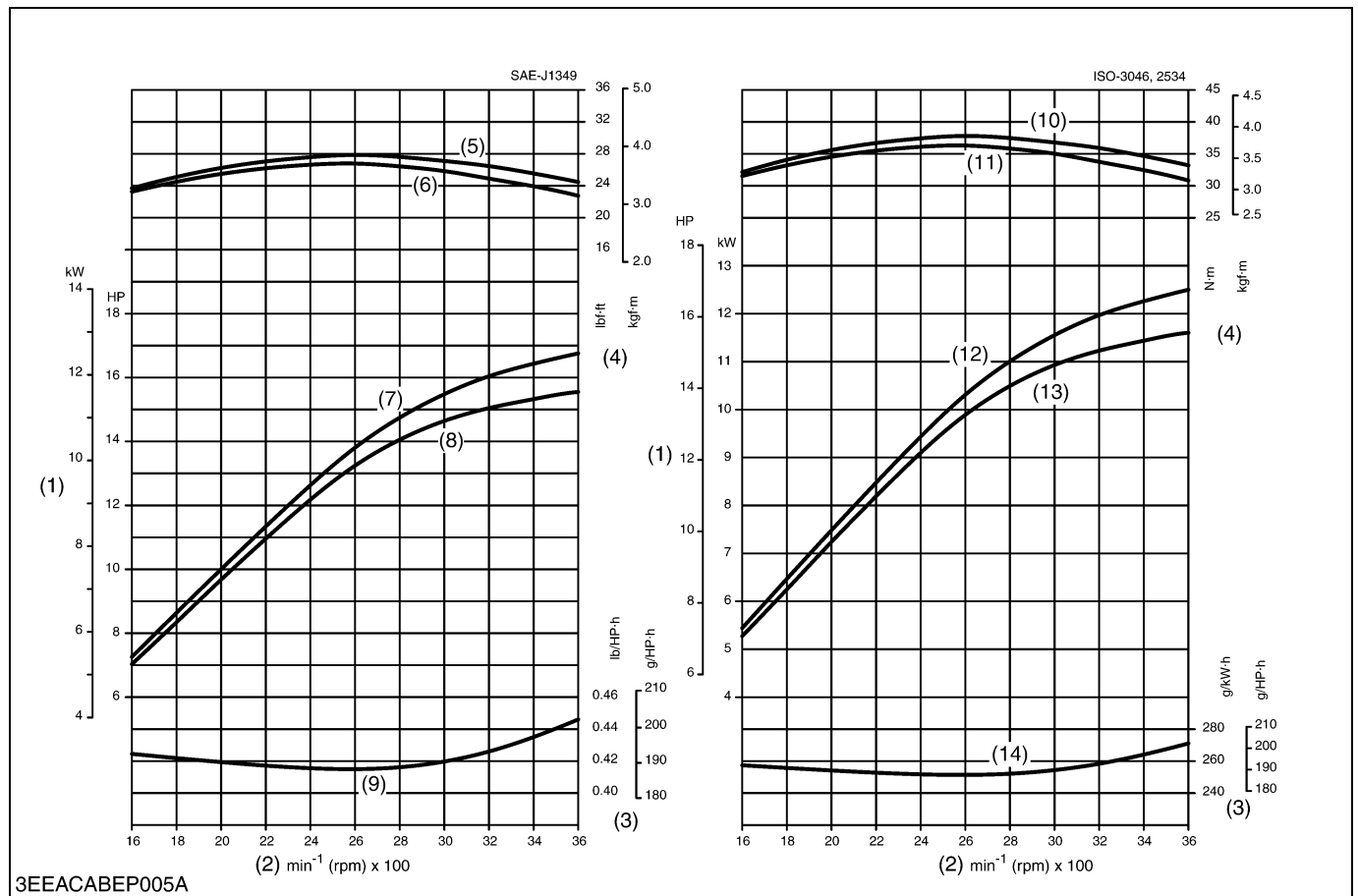

- (1) Brake Horsepower
- (2) Engine Speed
- (3) B.S.F.C.
- (4) Torque

- (5) Gross Intermittent Torque
- (6) Net Intermittent Torque
- (7) Gross Intermittent B.H.P.
- (8) Net Intermittent B.H.P.

- (9) Net Intermittent B.S.F.C.
- (10) Gross Torque
- (11) Overload Torque

- (12) Gross B.H.P.
- (13) Overload B.H.P.
- (14) Overload B.S.F.C.

■ D662-E2B

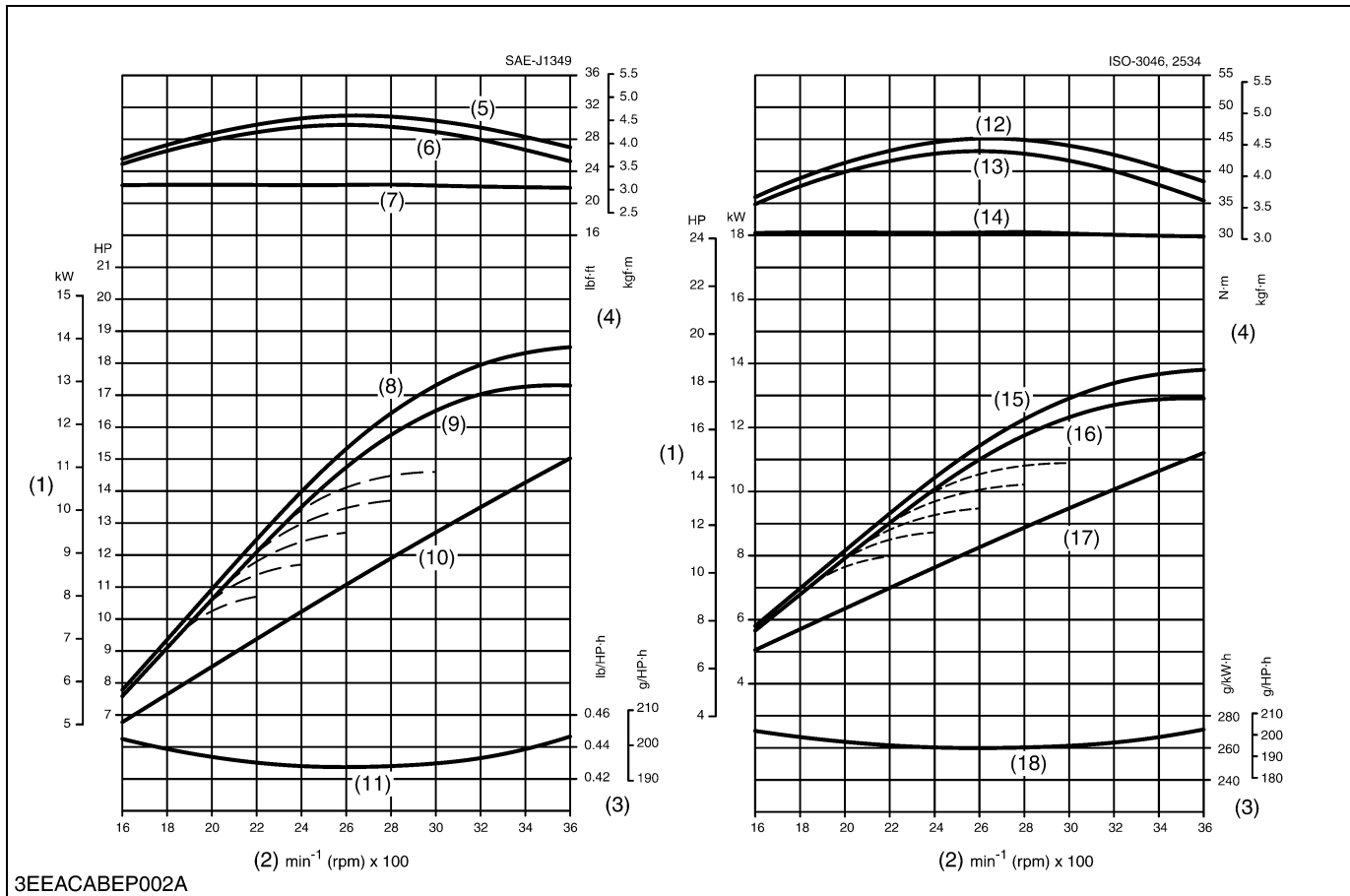

3EEACABEP002A

- | | | | |
|-------------------------------|-------------------------------|--------------------------------|------------------------|
| (1) Brake Horsepower | (6) Net Intermittent Torque | (11) Net Intermittent B.S.F.C. | (15) Gross B.H.P. |
| (2) Engine Speed | (7) Net Continuous Torque | (12) Gross Torque | (16) Overload B.H.P. |
| (3) B.S.F.C. | (8) Gross Intermittent B.H.P. | (13) Overload Torque | (17) Continuous B.H.P. |
| (4) Torque | (9) Net Intermittent B.H.P. | (14) Continuous Torque | (18) Overload B.S.F.C. |
| (5) Gross Intermittent Torque | (10) Net Continuous B.H.P. | | |

■ D722-E2B

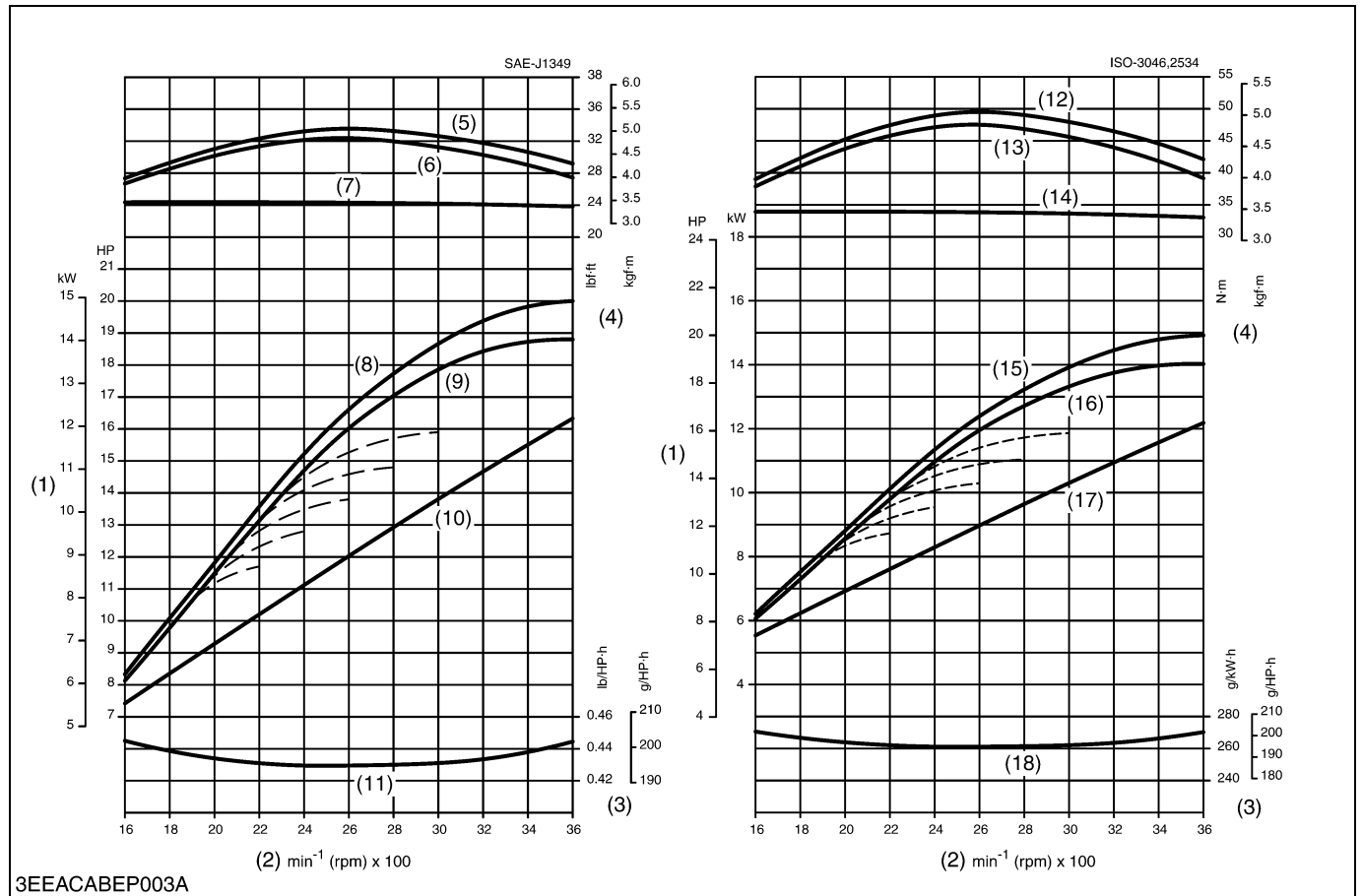

- (1) Brake Horsepower
- (2) Engine Speed
- (3) B.S.F.C.
- (4) Torque
- (5) Gross Intermitent Torque

- (6) Net Intermitent Torque
- (7) Net Continuous Torque
- (8) Gross Intermitent B.H.P.
- (9) Net Intermitent B.H.P.
- (10) Net Continuous B.H.P.

- (11) Net Intermitent B.S.F.C.
- (12) Gross Torque
- (13) Overload Torque
- (14) Continuous Torque

- (15) Gross B.H.P.
- (16) Overload B.H.P.
- (17) Continuous B.H.P.
- (18) Overload B.S.F.C.

■ D782-E2B

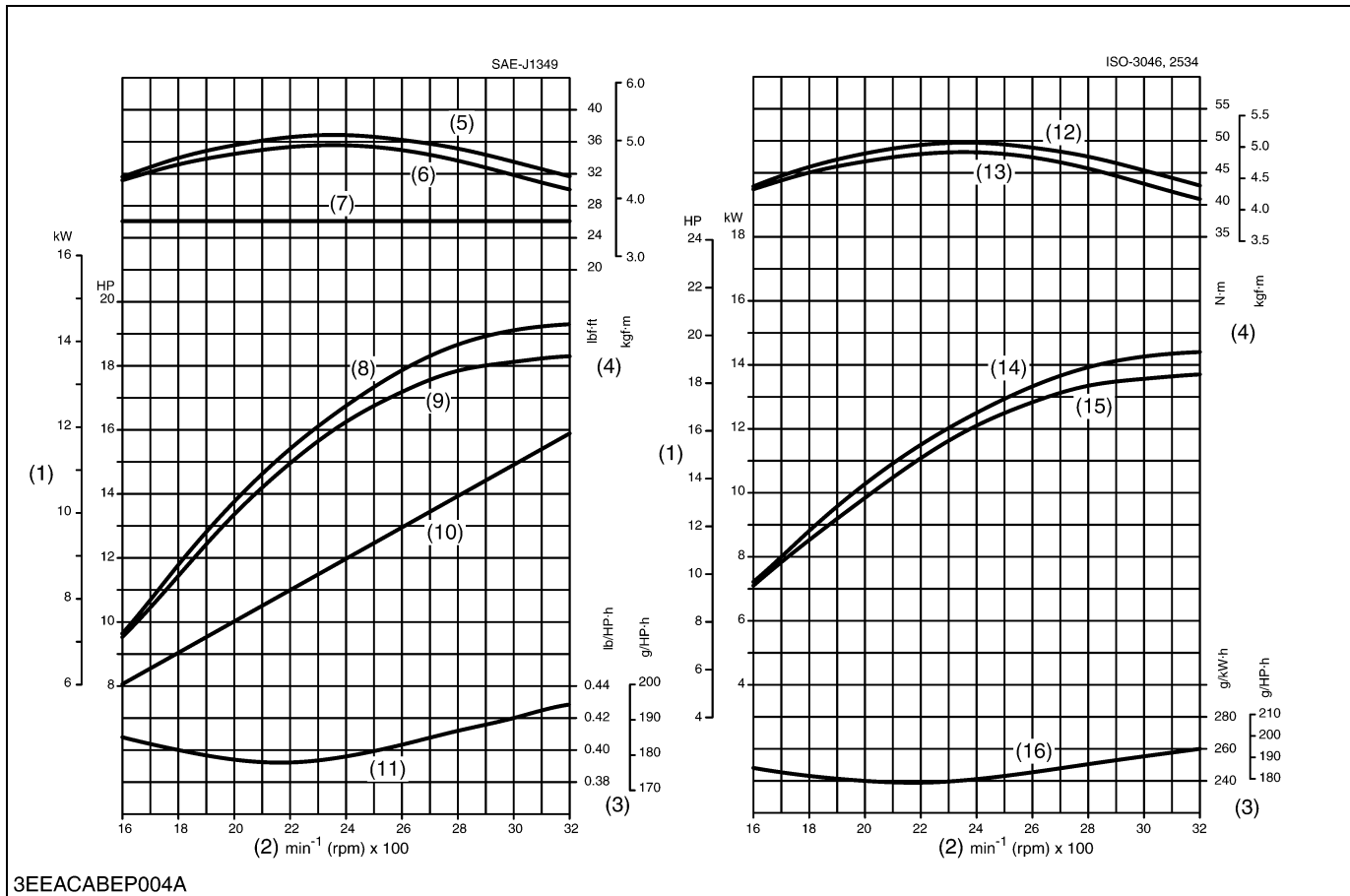

3EEACABEP004A

- | | | | |
|----------------------|-------------------------------|--------------------------------|------------------------|
| (1) Brake Horsepower | (5) Gross Intermittent Torque | (9) Net Intermittent B.H.P. | (13) Overload Torque |
| (2) Engine Speed | (6) Net Intermittent Torque | (10) Net Continuous B.H.P. | (14) Gross B.H.P. |
| (3) B.S.F.C. | (7) Net Continuous Torque | (11) Net Intermittent B.S.F.C. | (15) Overload B.H.P. |
| (4) Torque | (8) Gross Intermittent B.H.P. | (12) Gross Torque | (16) Overload B.S.F.C. |

■ D902-E2B (3200 min⁻¹ (rpm) spec.)

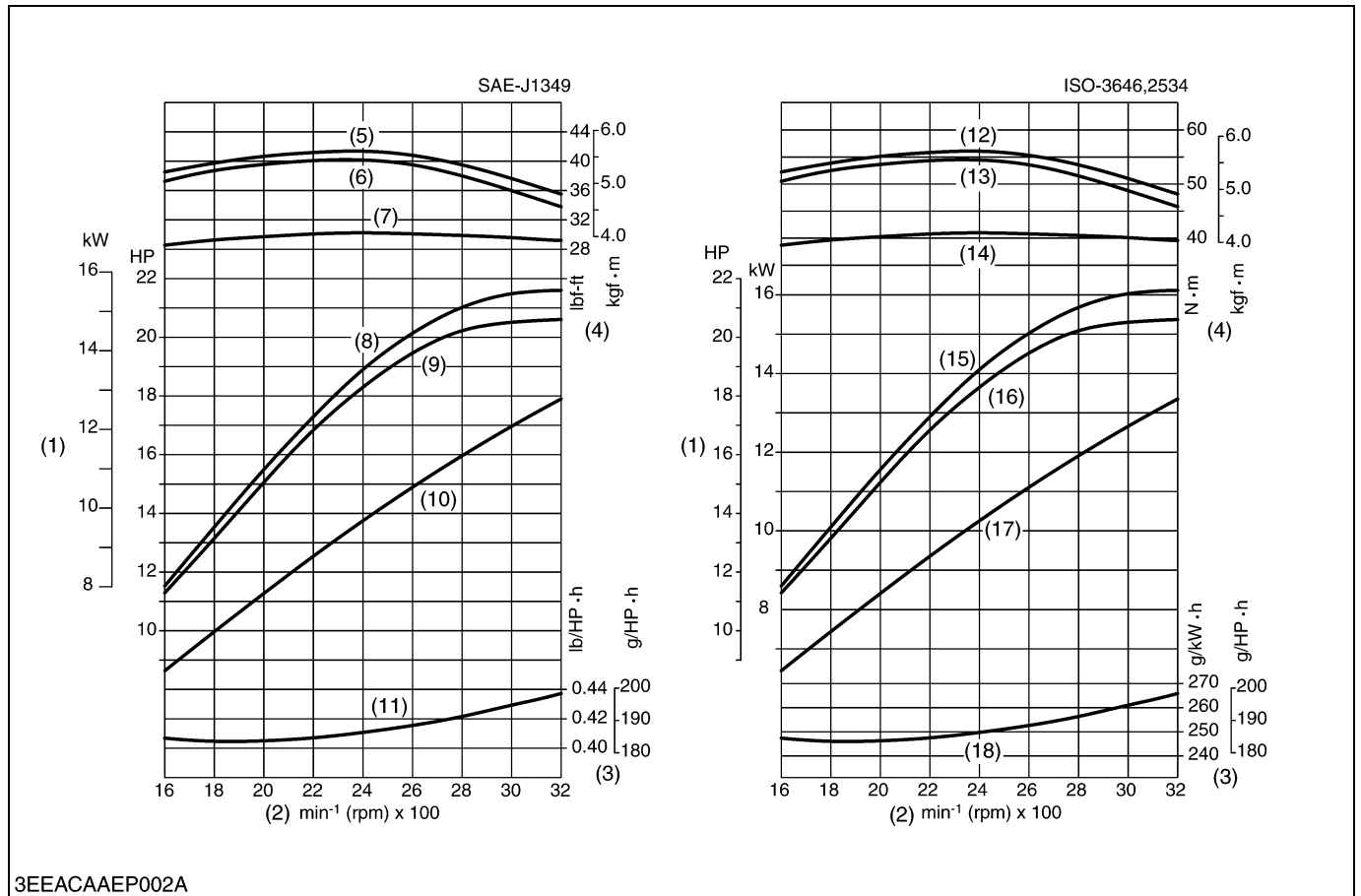

- (1) Brake Horsepower
- (2) Engine Speed
- (3) B.S.F.C.
- (4) Torque
- (5) Gross Intermittent Torque

- (6) Net Intermittent Torque
- (7) Net Continuous Torque
- (8) Gross Intermittent B.H.P.
- (9) Net Intermittent B.H.P.
- (10) Net Continuous B.H.P.

- (11) Net Intermittent B.S.F.C.
- (12) Gross Torque
- (13) Overload Torque
- (14) Continuous Torque

- (15) Gross B.H.P.
- (16) Overload B.H.P.
- (17) Continuous B.H.P.
- (18) Overload B.S.F.C.

■ D902-E2B (3600 min⁻¹ (rpm) spec.)

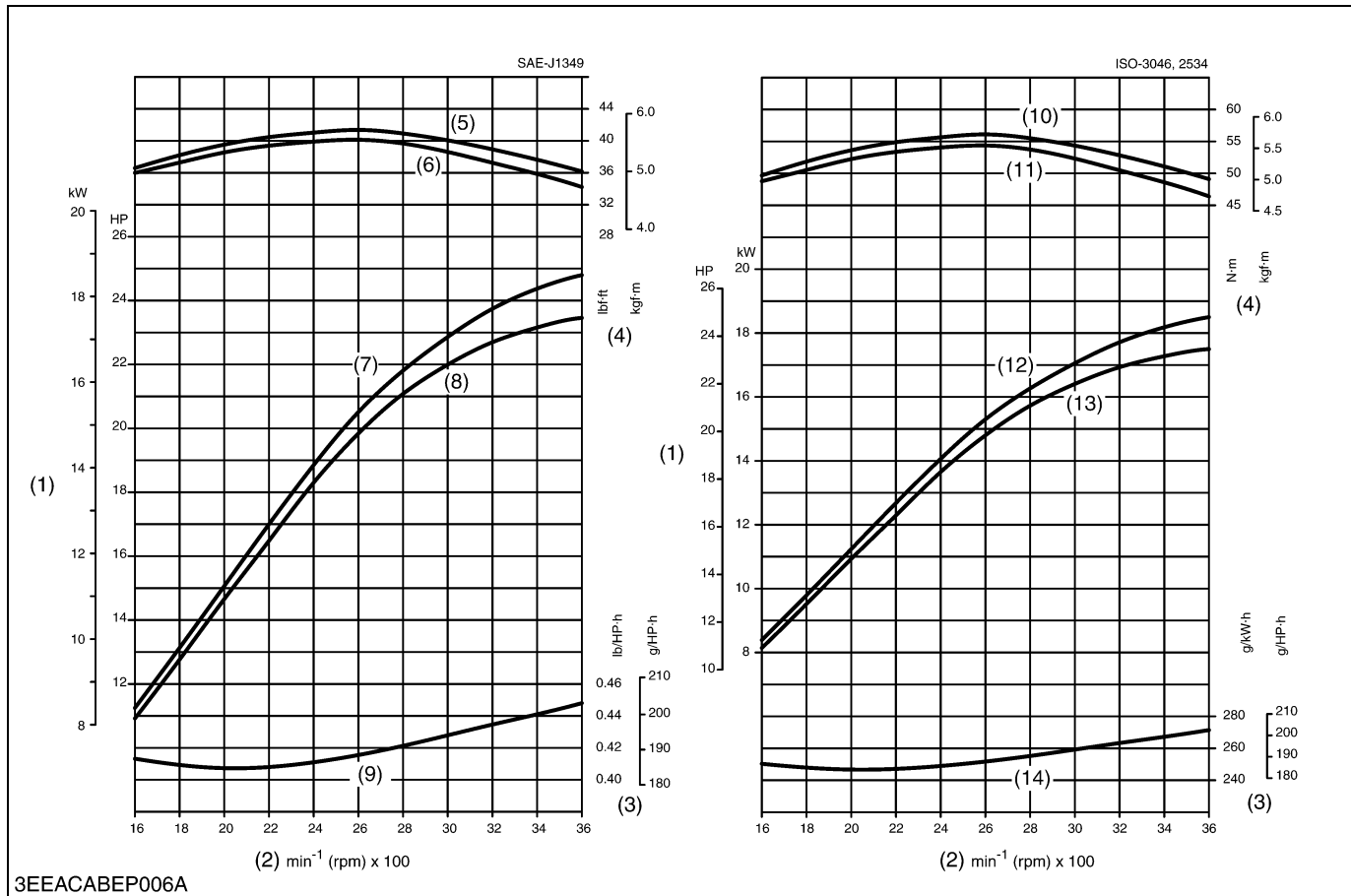

3EEACABEP006A

- | | | | |
|----------------------|-------------------------------|-------------------------------|------------------------|
| (1) Brake Horsepower | (5) Gross Intermittent Torque | (9) Net Intermittent B.S.F.C. | (12) Gross B.H.P. |
| (2) Engine Speed | (6) Net Intermittent Torque | (10) Gross Torque | (13) Overload B.H.P. |
| (3) B.S.F.C. | (7) Gross Intermittent B.H.P. | (11) Overload Torque | (14) Overload B.S.F.C. |
| (4) Torque | (8) Net Intermittent B.H.P. | | |

DIMENSIONS

■ Z482-E2B

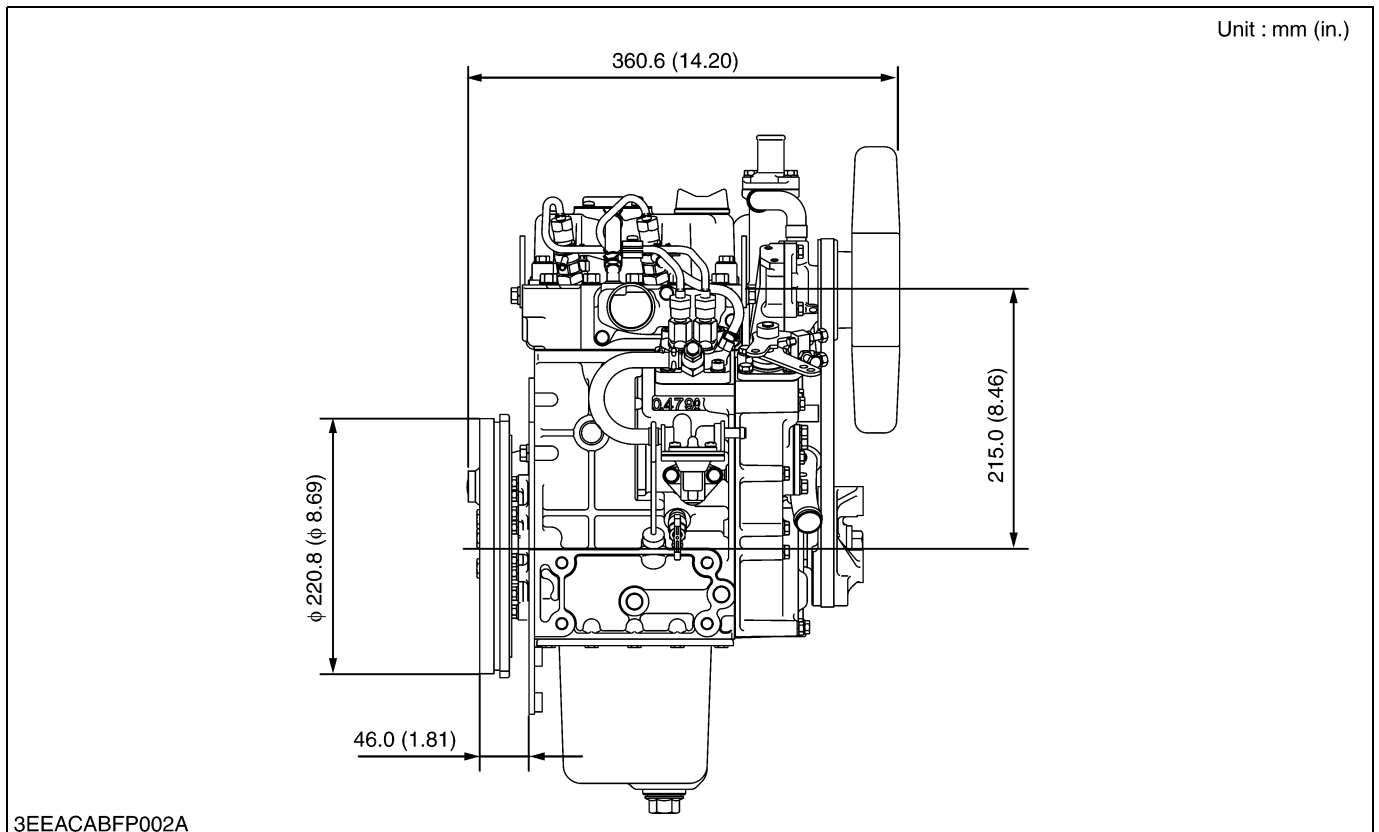
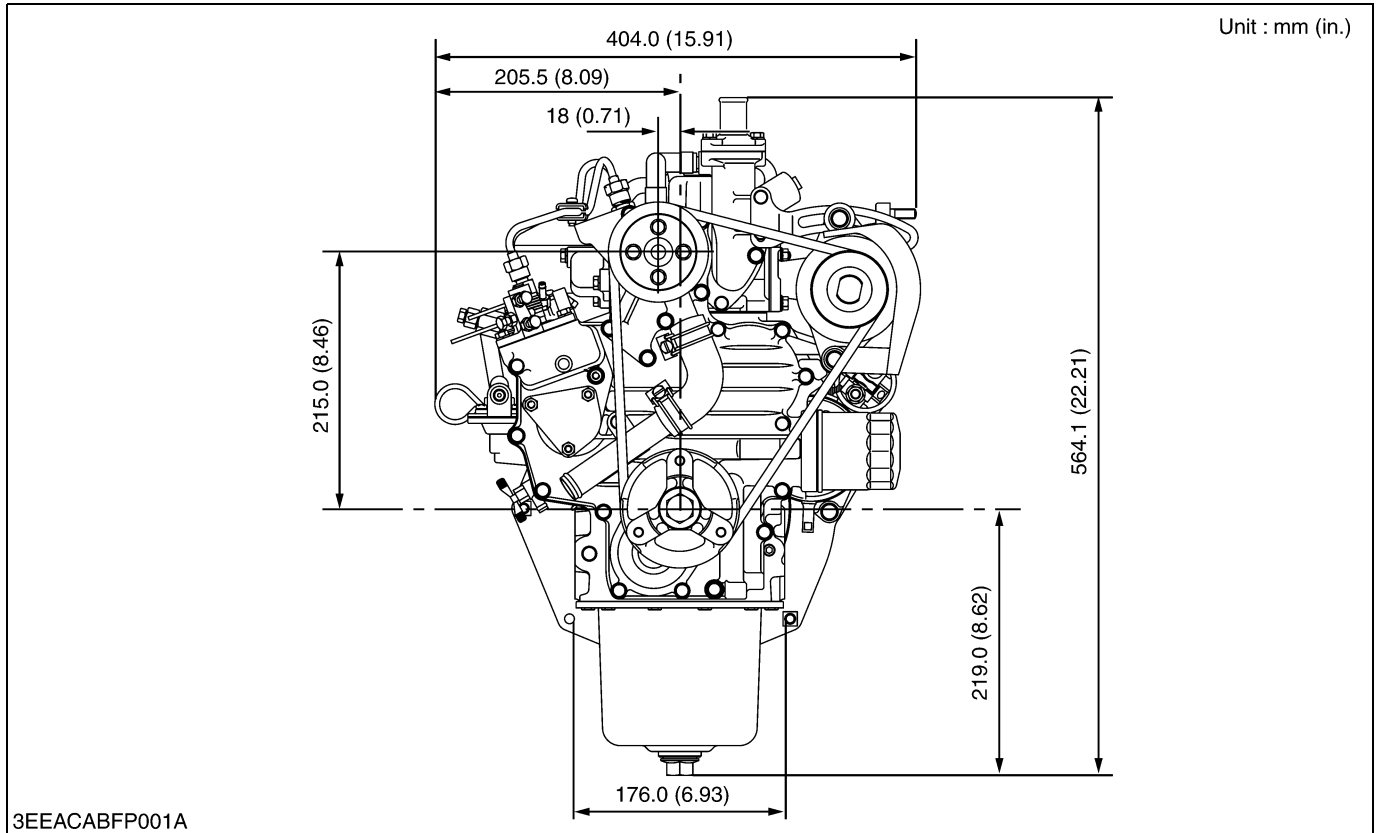

■ Z602-E2B

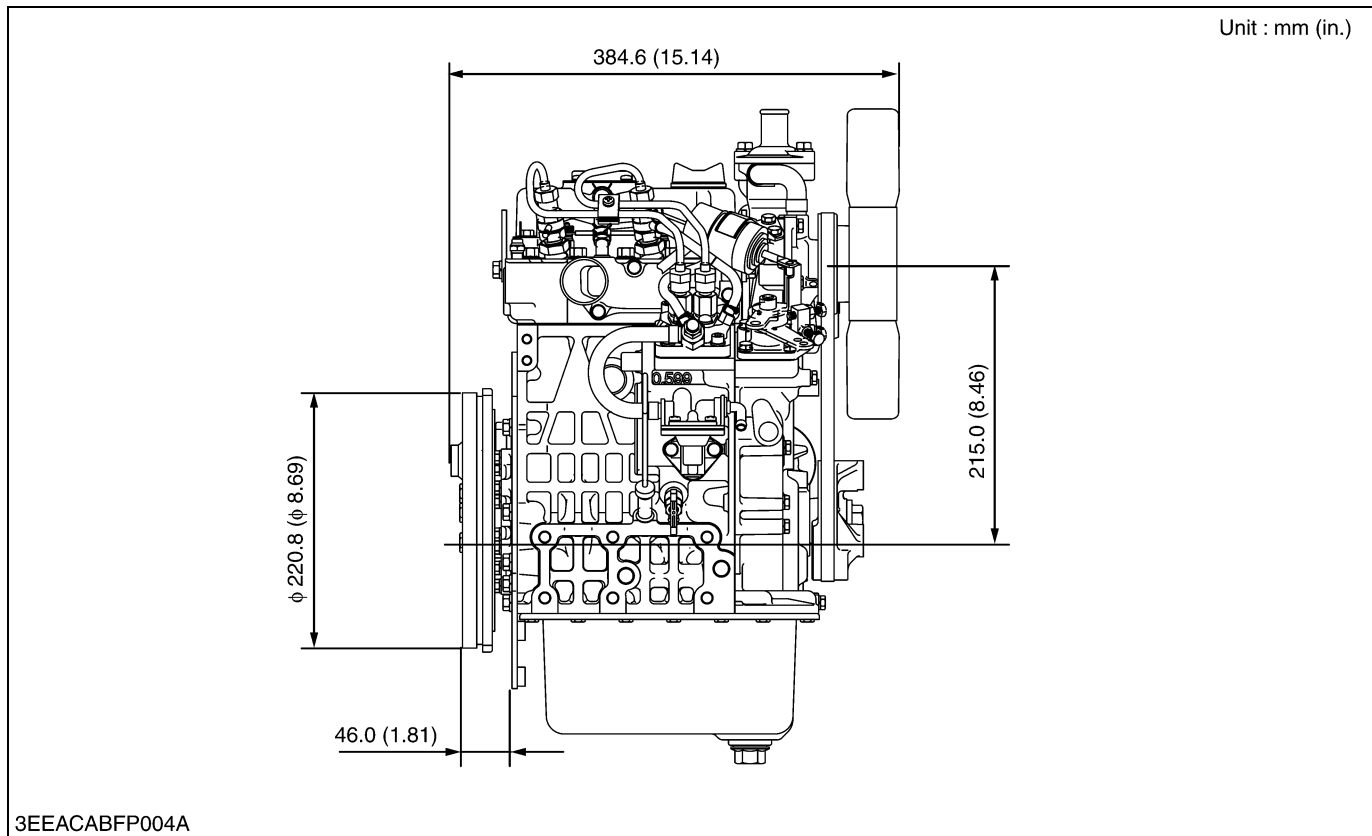
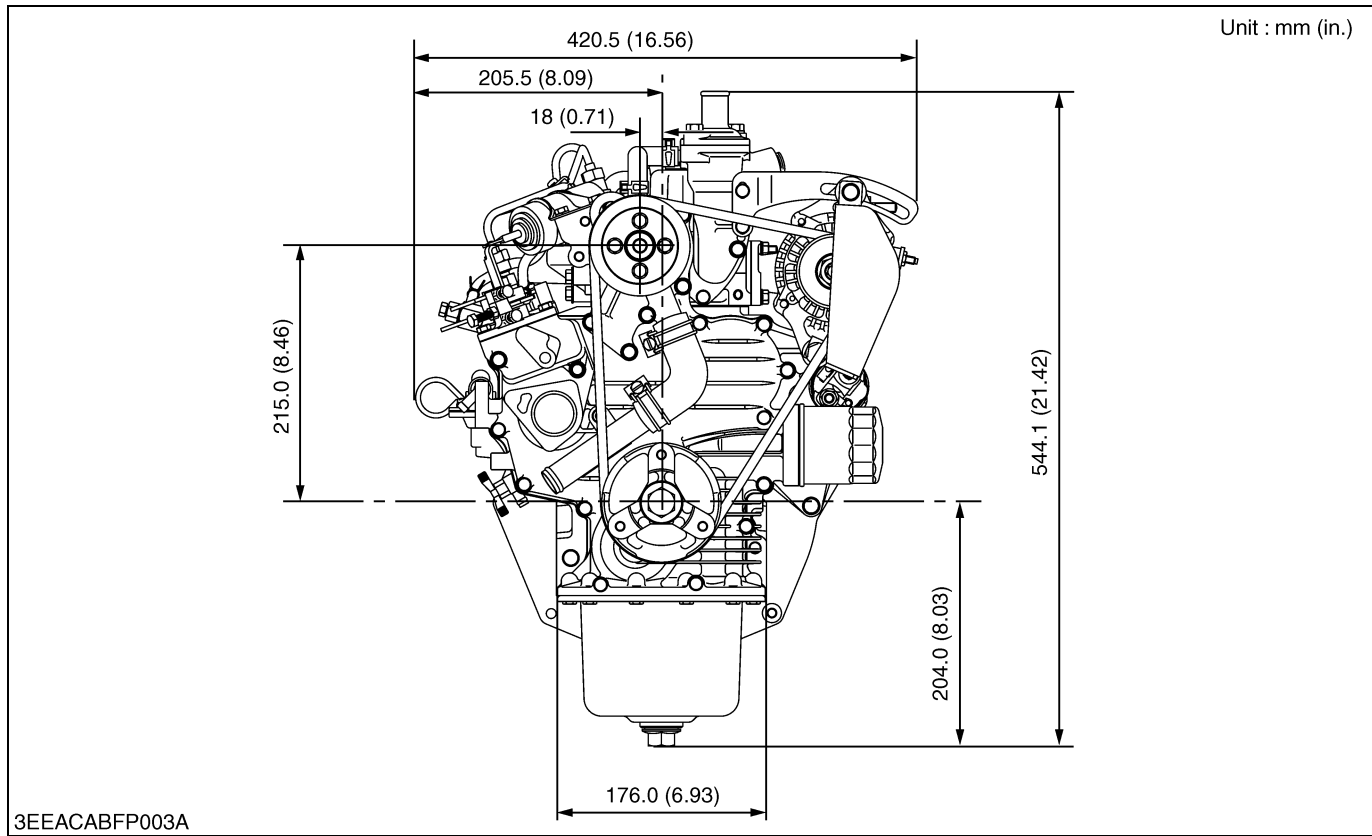

■ D662-E2B, D722-E2B

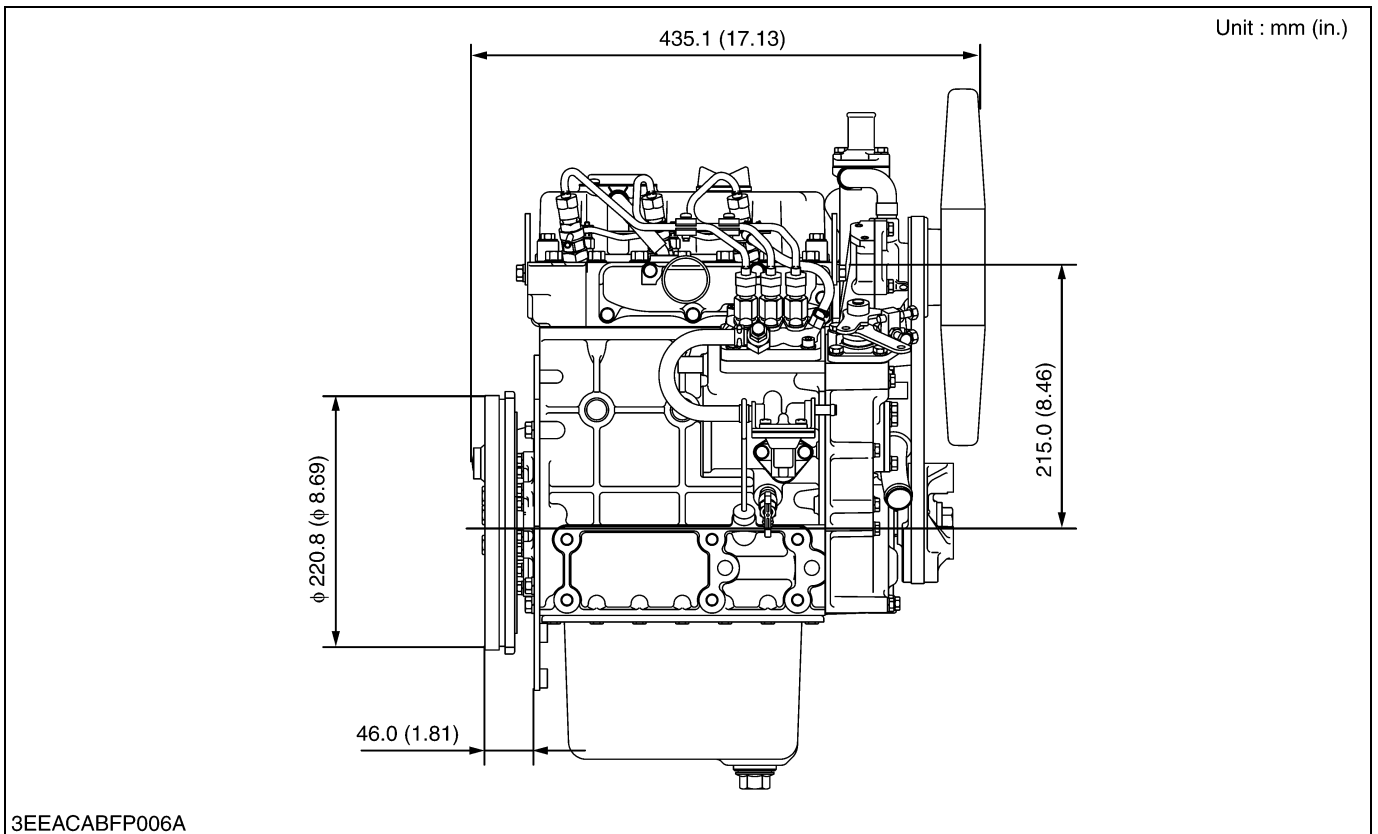
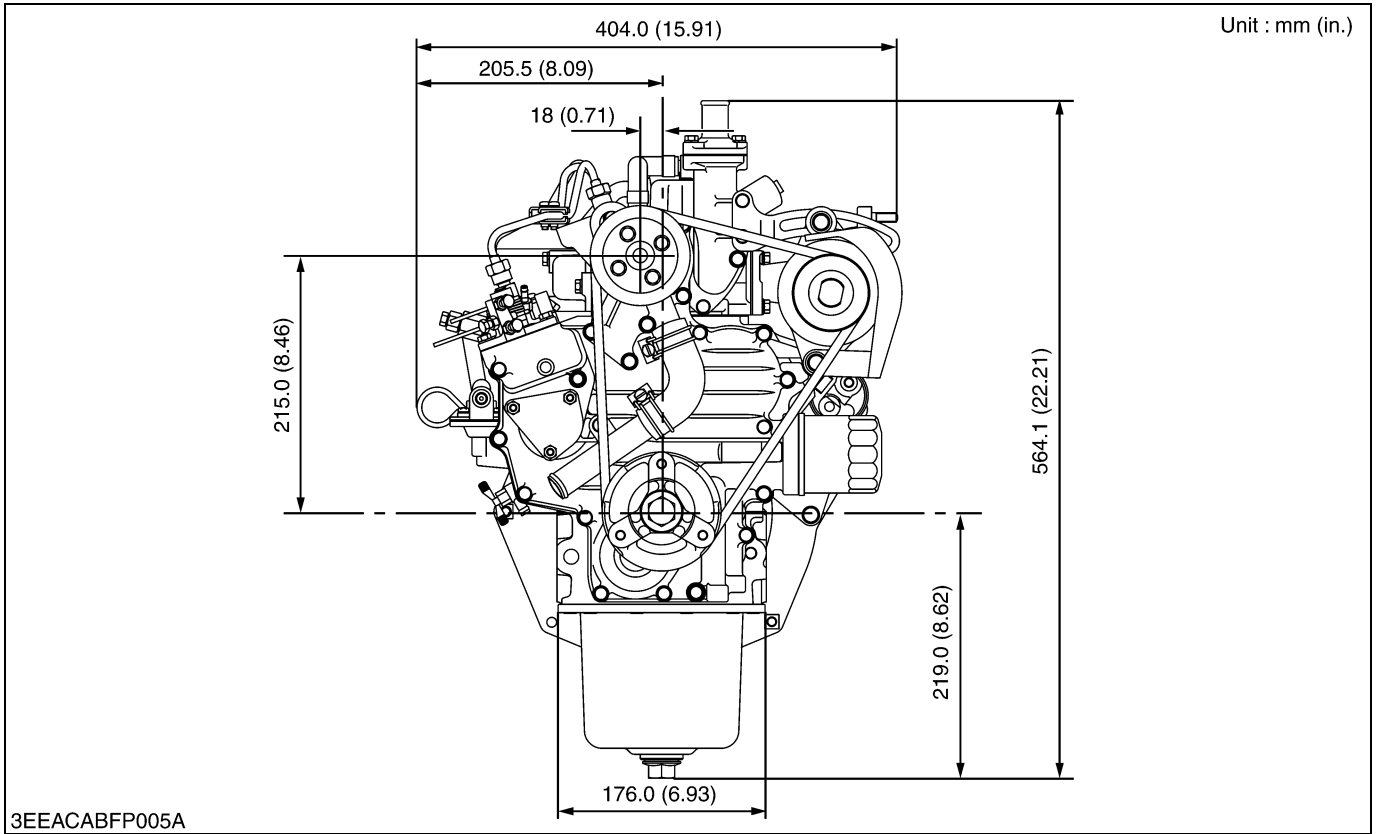

■ D782-E2B

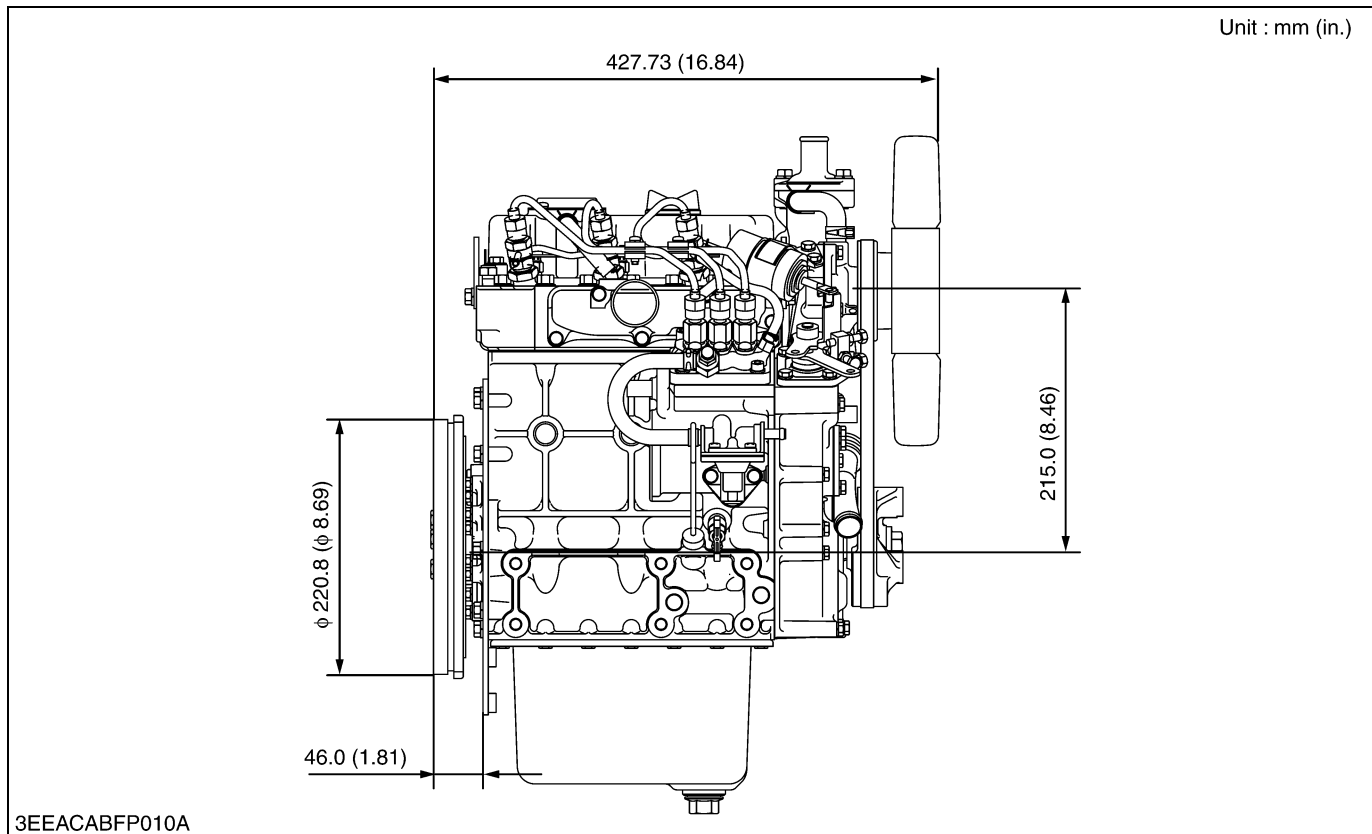
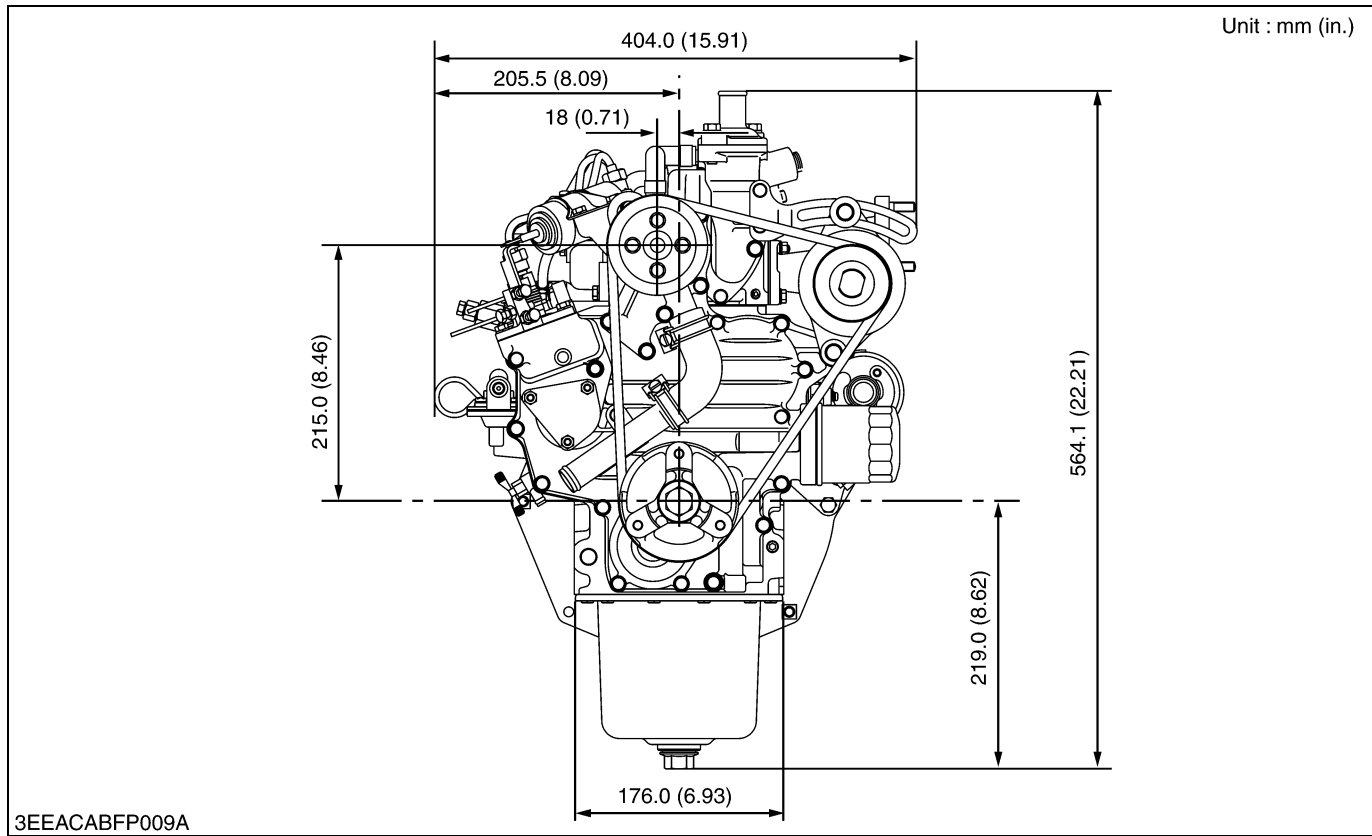

■ D902-E2B

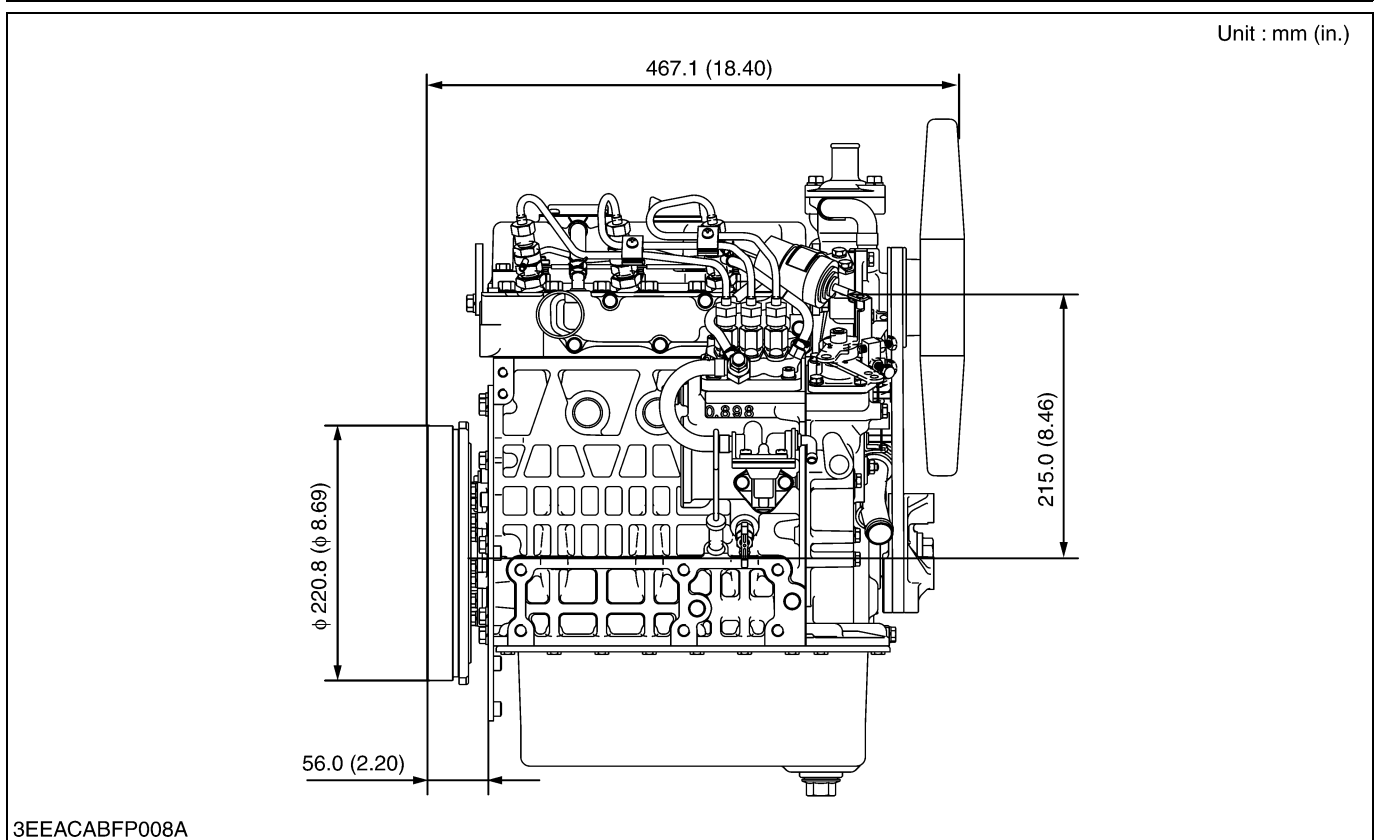
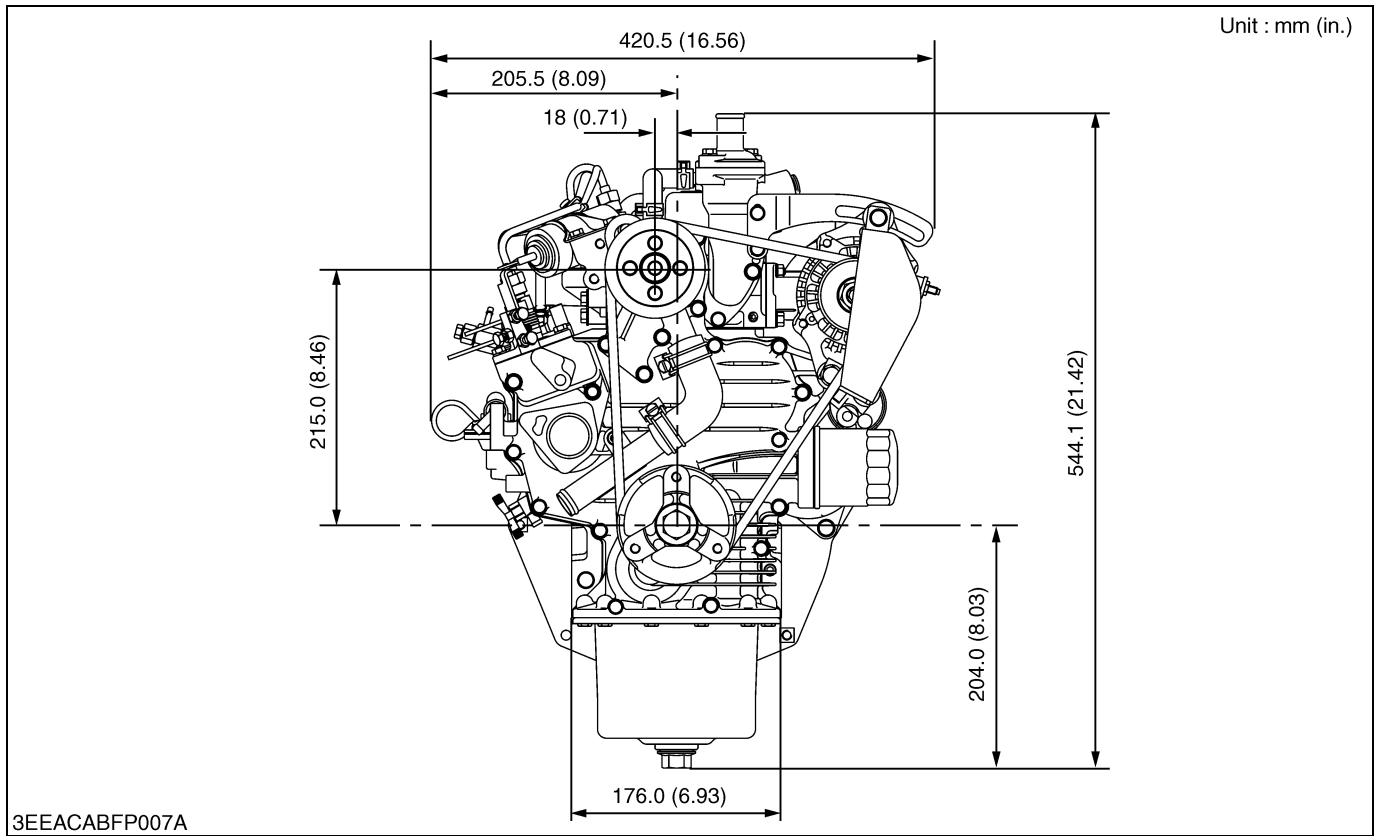

GENERAL

CONTENTS

1. ENGINE IDENTIFICATION.....	G-1
[1] MODEL NAME AND ENGINE SERIAL NUMBER	G-1
[2] E2B ENGINE.....	G-2
[3] CYLINDER NUMBER	G-2
2. GENERAL PRECAUTIONS.....	G-3
3. MAINTENANCE CHECK LIST.....	G-4
4. CHECK AND MAINTENANCE.....	G-6
[1] DAILY CHECK POINTS.....	G-6
[2] CHECK POINTS OF INITIAL 50 HOURS.....	G-8
[3] CHECK POINT OF EVERY 50 HOURS	G-10
[4] CHECK POINT OF EVERY 75 HOURS	G-11
[5] CHECK POINTS OF EVERY 100 HOURS.....	G-12
[6] CHECK POINT OF EVERY 150 HOURS	G-15
[7] CHECK POINTS OF EVERY 200 HOURS.....	G-15
[8] CHECK POINTS OF EVERY 400 HOURS.....	G-16
[9] CHECK POINTS OF EVERY 500 HOURS.....	G-17
[10]CHECK POINTS OF EVERY 1 OR 2 MONTHS.....	G-19
[11]CHECK POINT OF EVERY YEAR.....	G-21
[12]CHECK POINT OF EVERY 800 HOURS	G-22
[13]CHECK POINTS OF EVERY 1500 HOURS.....	G-23
[14]CHECK POINTS OF EVERY 3000 HOURS.....	G-25
[15]CHECK POINTS OF EVERY 2 YEARS.....	G-28
5. SPECIAL TOOLS.....	G-32

1. ENGINE IDENTIFICATION

[1] MODEL NAME AND ENGINE SERIAL NUMBER

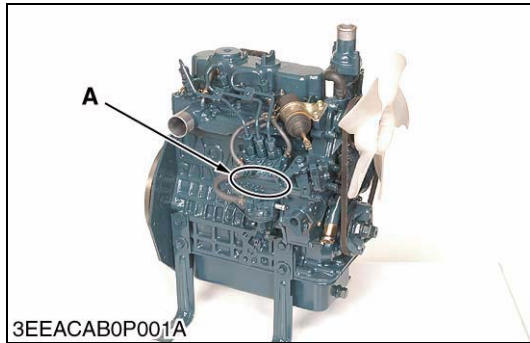

When contacting the manufacture, always specify your engine model name and serial number.

The engine model and its serial number need to be identified before the engine can be serviced or parts replaced.

■ Engine Serial Number

The engine serial number is an identified number for the engine. It is marked after the engine model number.

It indicates month and year of manufacture as follows.

• Year of manufacture

Alphabet or Number	Year	Alphabet or Number	Year
4	2004	G	2016
5	2005	H	2017
6	2006	J	2018
7	2007	K	2019
8	2008	L	2020
9	2009	M	2021
A	2010	N	2022
B	2011	P	2023
C	2012	R	2024
D	2013	S	2025
E	2014	T	2026
F	2015	V	2027

A : Engine Model Name and Serial Number

W1010477

- **Month of manufacture**

Month	Engine Serial Number	
	0001 ~ 9999	10000 ~
January	A0001 ~ A9999	B0001 ~
February	C0001 ~ C9999	D0001 ~
March	E0001 ~ E9999	F0001 ~
April	G0001 ~ G9999	H0001 ~
May	J0001 ~ J9999	K0001 ~
June	L0001 ~ L9999	M0001 ~
July	N0001 ~ N9999	P0001 ~
August	Q0001 ~ Q9999	R0001 ~
September	S0001 ~ S9999	T0001 ~
October	U0001 ~ U9999	V0001 ~
November	W0001 ~ W9999	X0001 ~
December	Y0001 ~ Y9999	Z0001 ~

e.g. D902-5A0001

“5” indicates 2005 and “A” indicates January.

So, 5A indicates that the engine was manufactured in January, 2005.

W1011076

[2] E2B ENGINE

[ex. Model Name D902-**E2B**-XXXX]

The emission controls that have been put into effect in various countries to prevent air pollution will be stepped up. The time to enforce the regulations differs depending on the engine output classifications.

Kubota has been supplying the diesel engines conforming to the emission regulations in respective countries. Exhaust emissions regulations shift to the second stage. Kubota executed the improvement of the engine according to this regulation.

In order to discriminate the engines conforming to Tier 1 / Phase 1 requirements and those conforming to Tier 2 / Phase 2 requirements, we have adopted E2B as a new model name for the engines conforming Tier 2 / Phase 2 regulations.

In the after-sale services for SM-E2B series engines, only use the dedicated parts for E2B models and carry out the maintenance services accordingly.

[3] CYLINDER NUMBER

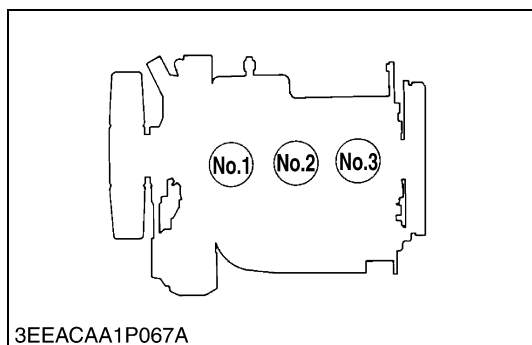

The cylinder numbers of KUBOTA diesel engine are designated as shown in the figure.

The sequence of cylinder numbers is given as No.1, No.2 and No.3 starting from the gear case side.

W1011077

2. GENERAL PRECAUTIONS

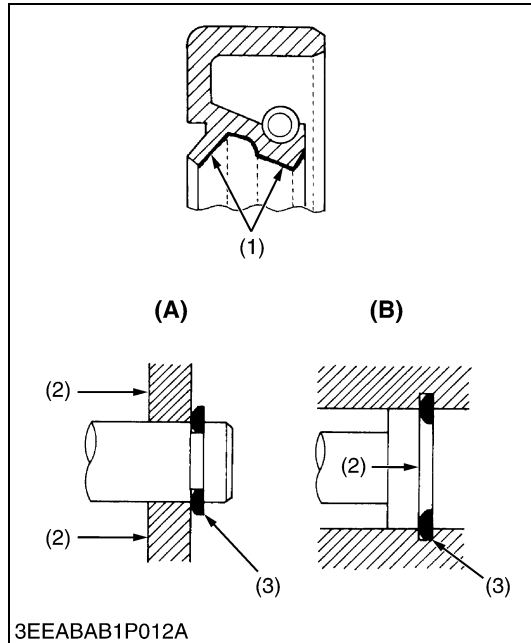

- During disassembly, carefully arrange removed parts in a clean area to prevent confusion later. Screws, bolts and nuts should be replaced in their original position to prevent reassembly errors.
- When special tools are required, use KUBOTA genuine special tools. Special tools which are not frequently used should be made according to the drawings provided.
- Before disassembling or servicing live wires, make sure to always disconnect the grounding cable from the battery first.
- Remove oil and dirt from parts before measuring.
- Use only KUBOTA genuine parts for parts replacement to maintain engine performance and to ensure safety.
- Gaskets and O-rings must be replaced during reassembly. Apply grease to new O-rings or oil seals before assembling.
- When reassembling external or internal snap rings, position them so that the sharp edge faces against the direction from which force is applied.
- Be sure to perform run-in the serviced or reassembled engine. Do not attempt to give heavy load at once, or serious damage may result to the engine.

- (1) Grease
 (2) Force
 (3) Place the Sharp Edge against the Direction of Force

(A) External Snap Ring
(B) Internal Snap Ring

W1011734

3. MAINTENANCE CHECK LIST

To maintain long-lasting and safe engine performance, make it a rule to carry out regular inspections by following the table below.

Item		Service Interval												
		Every												
		50 hrs	75 hrs	100 hrs	150 hrs	200 hrs	400 hrs	500 hrs	1 or 2 months	1 year	800 hrs	1500 hrs	3000 hrs	2 years
*Checking fuel hoses and clamp bands		☆												
Changing Engine oil	(1) Oil pan depth (101 mm, 3.98 in.)	★	☆											
	(2) Oil pan depth (121 mm, 4.76 in.)	★		☆										
	(3) Extended oil pan depth (101 mm, 3.98 in.)	★		☆										
Checking fan belt tension and damage				☆										
*Cleaning air cleaner element (Replace the element after 6 times cleaning)				☆										
Cleaning fuel filter (element type)				☆										
Checking battery electrolyte level				☆										
Replacing oil filter cartridge	(1) Oil pan depth (101 mm, 3.98 in.)	★			☆									
	(2) Oil pan depth (121 mm, 4.76 in.)	★				☆								
	(3) Extended oil pan depth (101 mm, 3.98 in.)	★				☆								
Checking radiator hoses and clamp bands						☆								
*Checking intake air line						☆								
*Replacing fuel filter							☆							
Cleaning water jacket and radiator interior								☆						
Replacing fan belt								☆						

(1) This oil pan depth is optional for Z482-E2B, D662-E2B and D722-E2B.

(2) This oil pan depth is standard for Z482-E2B, D662-E2B, D722-E2B and D782-E2B.

(3) This oil pan depth is standard for Z602-E2B and D902-E2B.

★ Change engine oil and replace oil filter cartridge after the first 50 hours of operation.

* The items listed above (* marked) are registered as emission related critical parts by KUBOTA in the U.S. EPA nonroad emission regulation. As the engine owner, you are responsible for the performance of the required maintenance on the engine according to the above instruction.

W1029462

Item	Service Interval												
	Every												
	50 hrs	75 hrs	100 hrs	150 hrs	200 hrs	400 hrs	500 hrs	1 or 2 months	1 year	800 hrs	1500 hrs	3000 hrs	2 years
Recharging battery								☆					
*Replacing air cleaner element									☆				
Checking valve clearance										☆			
*Checking injection nozzle condition											☆		
*Checking injection timing												☆	
*Checking injection pump												☆	
*Replacing intake air line													☆
Replacing battery													☆
Replacing radiator hoses and clamp bands													☆
*Replacing fuel hoses and clamp bands													☆
Changing radiator coolant (L.L.C.)													☆

* The items listed above (* marked) are registered as emission related critical parts by KUBOTA in the U.S. EPA nonroad emission regulation. As the engine owner, you are responsible for the performance of the required maintenance on the engine according to the above instruction.

W1014630

**CAUTION**

- When changing or inspecting, be sure to level and stop the engine.

NOTE**Lubricating Oil**

With the emission control now in effect, the CF-4 and CG-4 lubricating oils have been developed for use of a low-sulfur fuel on-road vehicle engines. When an off-road vehicle engine runs on a high-sulfur fuel, it is advisable to employ the CF, CD or CE lubricating oil with a high total base number. If the CF-4 or CG-4 lubricating oil is used with a high-sulfur fuel, change the lubricating oil at shorter intervals.

- Lubricating oil recommended when a low-sulfur or high-sulfur fuel is employed.

Lubricating oil class	Fuel		Remarks
	Low sulfur (0.5 % ≥)	High sulfur	
CF	○	○	TBN ≥ 10
CF-4	○	X	
CG-4	○	X	

○ : Recommendable X : Not recommendable

W1035555

4. CHECK AND MAINTENANCE

[1] DAILY CHECK POINTS



Checking Engine Oil Level

1. Level the engine.
2. To check the oil level, draw out the dipstick (1), wipe it clean, reinsert it, and draw it out again.
Check to see that the oil level lies between the two notches.
3. If the level is too low, add new oil to the specified level.

■ IMPORTANT

- When using an oil of different maker or viscosity from the previous, drain old oil. Never mix two different types of oil.

■ NOTE

- Be sure to inspect the engine, locating it on a horizontal place. If placed on gradients, accurately, oil quantity may not be measured.
- Be sure to keep the oil level between upper and lower limits of the dipstick. Too much oil may cause a drop in output or excessive blow-by gas. On the closed breather type engine in which mist is sucked through port, too much oil may caused oil hammer. While too little oil, may seize the engine's rotating and sliding parts.

(1) Dipstick

W1016222

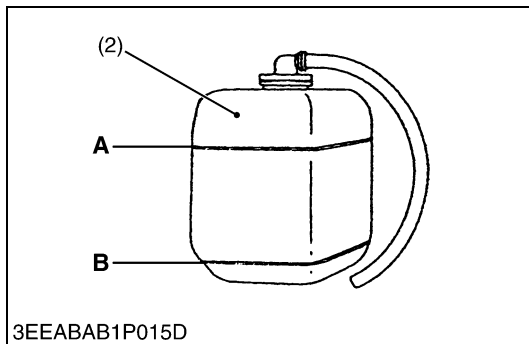
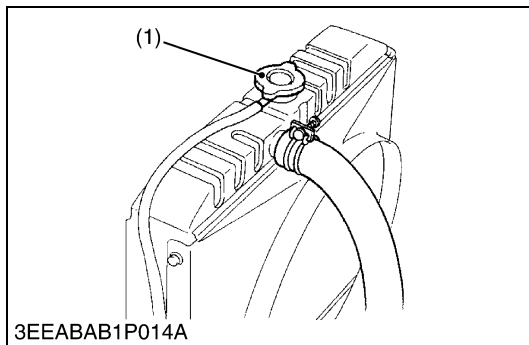

Checking and Replenish Coolant

1. Without recovery tank :
Remove the radiator cap (1) and check to see that the coolant level is just below the port.
With recovery tank (2) :
Check to see that the coolant level lies between **FULL (A)** and **LOW (B)**.
2. If coolant level is too low, check the reason for decreasing coolant.
(Case 1)
If coolant is decreasing by evaporation, replenish only fresh, soft water.
(Case 2)
If coolant is decreasing by leak, replenish coolant of the same manufacture and type in the specified mixture ratio (fresh, soft water and L.L.C.). If the coolant brand cannot be identified, drain out all of the remaining coolant and refill with a totally new brand of coolant mix.

⚠ CAUTION

- Do not remove the radiator cap until coolant temperature is below its boiling point. Then loosen the cap slightly to relieve any excess pressure before removing the cap completely.
- **IMPORTANT**
- During filling the coolant, air must be vented from the engine coolant passages. The air vents by jiggling the radiator upper and lower hoses.
 - Be sure to close the radiator cap securely. If the cap is loose or improperly closed, coolant may leak out and the engine could overheat.
 - Do not use an antifreeze and scale inhibitor at the same time.
 - Never mix the different type or brand of L.L.C..

(1) Radiator Cap
(2) Recovery Tank

A: FULL
B: LOW

W1035779

[2] CHECK POINTS OF INITIAL 50 HOURS

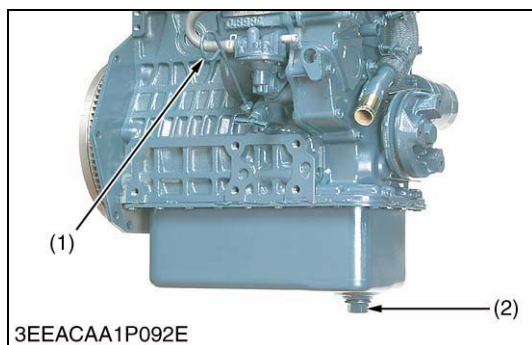

Changing Engine Oil

⚠ CAUTION

- **Be sure to stop engine before changing engine oil.**
- 1. Start and warm up the engine for approx. 5 minutes.
- 2. Place an oil pan underneath the engine.
- 3. To drain the used oil, remove the drain plug (2) at the bottom of the engine and drain the oil completely.
- 4. Screw the drain plug (2).
- 5. Fill new oil up to upper line on the dipstick (1).

■ IMPORTANT

- **When using an oil of different maker or viscosity from the previous one, remove all of the old oil.**
- **Never mix two different types of oil.**
- **Engine oil should have properties of API classification CD/CE/CF/CF-4/CG-4.**
- **Use the proper SAE Engine Oil according to ambient temperature.**
- **Upon an oil change, be sure to replace the gasket with new one.**

Above 25 °C (77 °F)	SAE 30 or SAE 10W-30 SAE 10W-40
0 °C to 25 °C (32 °F to 77 °F)	SAE 20 or SAE 10W-30 SAE 10W-40
Below 0 °C (32 °F)	SAE 10W or SAE 10W-30 SAE 10W-40

Models	Oil pan depth	Engine oil capacity	
		101 mm (3.98 in.)	121 mm (4.76 in.)
*Z482-E2B		2.1 L 0.55 U.S.gals	2.5 L 0.66 U.S.gals
*D662-E2B *D722-E2B		3.2 L 0.85 U.S.gals	3.8 L 1.00 U.S.gals
D782-E2B		–	3.6 L 0.95 U.S.gals
Z602-E2B		2.5 L 0.66 U.S.gals	–
D902-E2B		3.7 L 0.98 U.S.gals	–

* 101 mm (3.98 in.) oil pan depth is optional.

Tightening torque	Drain plug with copper gasket	M12 × 1.25	32.4 to 37.3 N·m 3.3 to 3.8 kgf·m 23.9 to 27.5 ft-lbs
		M22 × 1.5	63.7 to 73.5 N·m 6.5 to 7.5 kgf·m 47.0 to 54.2 ft-lbs
	Drain plug with rubber coated gasket	M22 × 1.5	44.1 to 53.9 N·m 4.5 to 5.5 kgf·m 32.5 to 39.8 ft-lbs

(1) Dipstick

(2) Drain Plug

W1016604

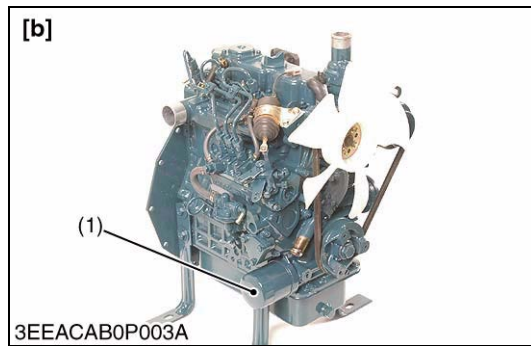

Replacing Oil Filter Cartridge

⚠ CAUTION

- **Be sure to stop the engine before changing filter cartridge.**
1. Remove the oil filter cartridge (1) with the filter wrench.
 2. Apply a slight coat of oil onto the new cartridge gasket.
 3. To install the new cartridge, screw it in by hand. Over tightening may cause deformation of rubber gasket.
 4. After the new cartridge has been replaced, the engine oil normally decrease a little. Thus see that the engine oil does not leak through the seal and be sure to read the oil level on the dipstick. Then, replenish the engine oil up to the specified level.

■ IMPORTANT

- **To prevent serious damage to the engine, replacement element must be highly efficient. Use only a KUBOTA genuine filter or its equivalent.**

■ NOTE

- **The oil pan of 101 mm (3.98 in.) depth is optional for Z482-E2B, D662-E2B and D722-E2B. This service interval is every 150 hours.**

(1) Engine Oil Filter Cartridge

[a] Standard Type

[b] One-side Maintenance Type

W1017137

[3] CHECK POINT OF EVERY 50 HOURS

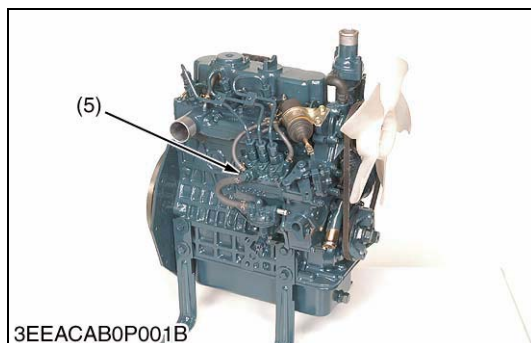
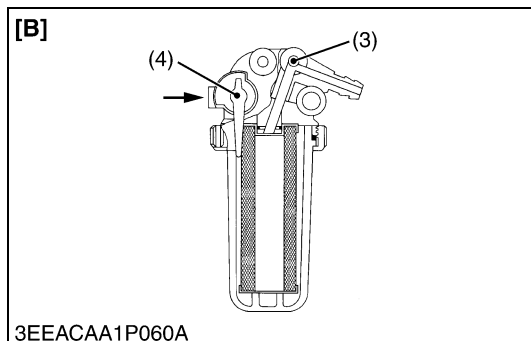
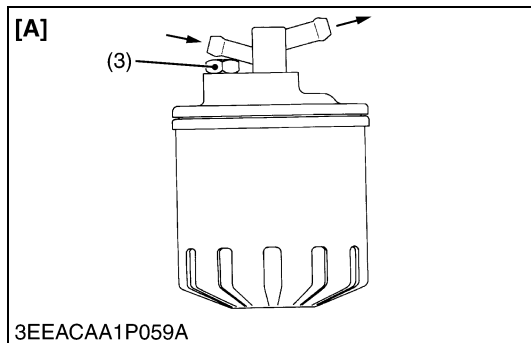
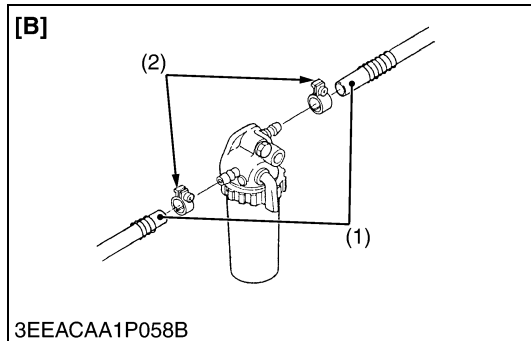
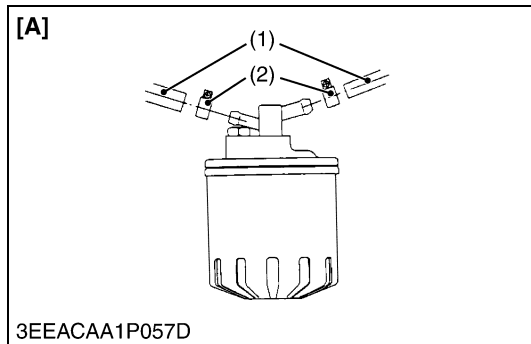

Checking Fuel Hose

1. If the clamp (2) is loose, apply oil to the threads and securely retighten it.
2. The fuel hose (1) is made of rubber and ages regardless of the period service.
Change the fuel hose together with the clamp every two years.
3. However, if the fuel hose and clamp are found to be damaged or deteriorate earlier than two years, then change or remedy.
4. After the fuel hose and the clamp have been changed, bleed the fuel system.



CAUTION

- Stop the engine when attempting the check and change prescribed above.

(When bleeding fuel system)

1. Fill the tank with fuel and open the cock (4). ([B] only.)
2. Loosen the air vent plug (3) of the fuel filter a few turns.
3. Screw back the plug when bubbles do not come up any more.
4. Open the air vent cock (5) on top of the fuel injection pump.
5. If equipped electrical fuel feed pump, turn the key to **AC** position and pump the fuel up for 10 to 15 seconds.
If equipped mechanical fuel feed pump, set the stop lever on stop position and crank the engine for 10 to 15 seconds.
6. Close securely the air vent cock after air bleeding.

NOTE

- Always keep the air vent cock on the fuel injection pump closed except when air is vented, or it may cause the engine to stop.

- (1) Fuel Hose
- (2) Clamp
- (3) Air Vent Plug
- (4) Fuel Cock
- (5) Air Vent Cock

[A] Cartridge Type

[B] Element Type

W1035921

[4] CHECK POINT OF EVERY 75 HOURS

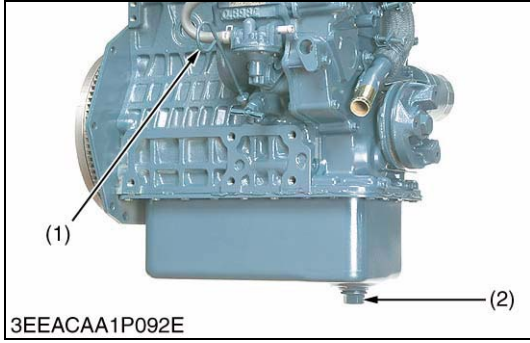

Changing Engine Oil (for Optional Depth Oil Pans)

⚠ CAUTION

- **Be sure to stop engine before changing engine oil.**
- 1. Start and warm up the engine for approx. 5 minutes.
- 2. Place an oil pan underneath the engine.
- 3. To drain the used oil, remove the drain plug (2) at the bottom of the engine and drain the oil completely.
- 4. Screw the drain plug (2).
- 5. Fill new oil up to upper line on the dipstick (1).

■ IMPORTANT

- **When using an oil of different maker or viscosity from the previous one, remove all of the old oil.**
- **Never mix two different types of oil.**
- **Engine oil should have properties of API classification CD/CE/CF/CF-4/CG-4.**
- **Use the proper SAE Engine Oil according to ambient temperature.**
- **Upon an oil change, be sure to replace the gasket with new one.**

Above 25 °C (77 °F)	SAE 30 or SAE 10W-30 SAE 10W-40
0 °C to 25 °C (32 °F to 77 °F)	SAE 20 or SAE 10W-30 SAE 10W-40
Below 0 °C (32 °F)	SAE 10W or SAE 10W-30 SAE 10W-40

Models	Engine oil capacity	
	101 mm (3.98 in.)	121 mm (4.76 in.)
*Z482-E2B	2.1 L 0.55 U.S.gals	2.5 L 0.66 U.S.gals
*D662-E2B *D722-E2B	3.2 L 0.85 U.S.gals	3.8 L 1.00 U.S.gals
D782-E2B	–	3.6 L 0.95 U.S.gals
Z602-E2B	2.5 L 0.66 U.S.gals	–
D902-E2B	3.7 L 0.98 U.S.gals	–

* 101 mm (3.98 in.) oil pan depth is optional.

Tightening torque	Drain plug with copper gasket	M12 × 1.25	32.4 to 37.3 N·m 3.3 to 3.8 kgf·m 23.9 to 27.5 ft-lbs
		M22 × 1.5	63.7 to 73.5 N·m 6.5 to 7.5 kgf·m 47.0 to 54.2 ft-lbs
	Drain plug with rubber coated gasket	M22 × 1.5	44.1 to 53.9 N·m 4.5 to 5.5 kgf·m 32.5 to 39.8 ft-lbs

(1) Dipstick

(2) Drain Plug

W1017177

[5] CHECK POINTS OF EVERY 100 HOURS

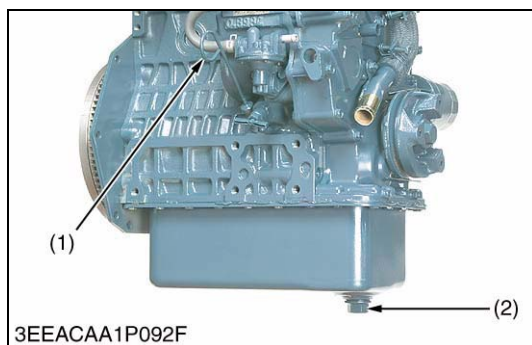

Changing Engine Oil (for Standard Depth Oil Pans)

⚠ CAUTION

- **Be sure to stop engine before changing engine oil.**
- 1. Start and warm up the engine for approx. 5 minutes.
- 2. Place an oil pan underneath the engine.
- 3. To drain the used oil, remove the drain plug (2) at the bottom of the engine and drain the oil completely.
- 4. Screw the drain plug (2).
- 5. Fill new oil up to upper line on the dipstick (1).

■ IMPORTANT

- **When using an oil of different maker or viscosity from the previous one, remove all of the old oil.**
- **Never mix two different types of oil.**
- **Engine oil should have properties of API classification CD/CE/CF/CF-4/CG-4.**
- **Use the proper SAE Engine Oil according to ambient temperature.**
- **Upon an oil change, be sure to replace the gasket with new one.**

Above 25 °C (77 °F)	SAE 30 or SAE 10W-30 SAE 10W-40
0 °C to 25 °C (32 °F to 77 °F)	SAE 20 or SAE 10W-30 SAE 10W-40
Below 0 °C (32 °F)	SAE 10W or SAE 10W-30 SAE 10W-40

Models	Oil pan depth	Engine oil capacity	
		101 mm (3.98 in.)	121 mm (4.76 in.)
*Z482-E2B		2.1 L 0.55 U.S.gals	2.5 L 0.66 U.S.gals
*D662-E2B *D722-E2B		3.2 L 0.85 U.S.gals	3.8 L 1.00 U.S.gals
D782-E2B		–	3.6 L 0.95 U.S.gals
Z602-E2B		2.5 L 0.66 U.S.gals	–
D902-E2B		3.7 L 0.98 U.S.gals	–

* 101 mm (3.98 in.) oil pan depth is optional.

Tightening torque	Drain plug with copper gasket	M12 × 1.25	32.4 to 37.3 N·m 3.3 to 3.8 kgf·m 23.9 to 27.5 ft-lbs
		M22 × 1.5	63.7 to 73.5 N·m 6.5 to 7.5 kgf·m 47.0 to 54.2 ft-lbs
	Drain plug with rubber coated gasket	M22 × 1.5	44.1 to 53.9 N·m 4.5 to 5.5 kgf·m 32.5 to 39.8 ft-lbs

(1) Dipstick

(2) Drain Plug

W1017548

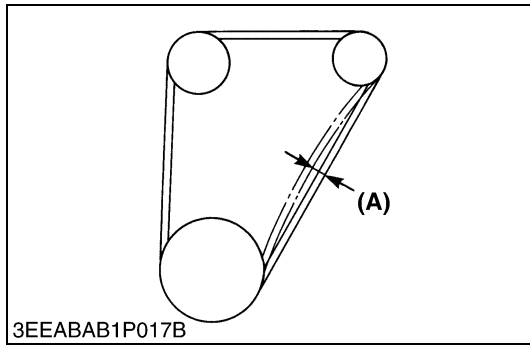

Fan Belt Tension

1. Measure the deflection **(A)**, depressing the belt halfway between the fan drive pulley and alternator pulley at specified force 98 N (10 kgf, 22 lbs).
2. If the measurement is not within the factory specifications, loosen the alternator mounting screws and relocate the alternator to adjust.

Deflection (A)	Factory spec.	7.0 to 9.0 mm 0.28 to 0.35 in.
-----------------------	---------------	-----------------------------------

(A) Deflection

W1208957



Fan Belt Damage and Wear

1. Check the fan belt for damage.
2. If the fan belt is damaged, replace it.
3. Check if the fan belt is worn and sunk in the pulley groove.
4. If the fan belt is nearly worn out and deeply sunk in the pulley groove, replace it.

(A) Good

(B) Bad

W1209480

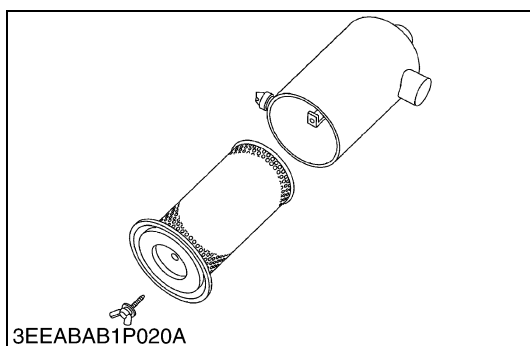
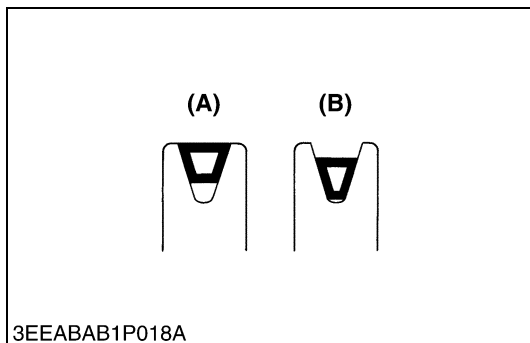

Cleaning Air Cleaner Element

1. Remove the air cleaner element.
2. Use clean dry compressed air on the inside of the element. Pressure of compressed air must be under 205 kPa (2.1 kgf/cm², 30 psi). Maintain reasonable distance between the nozzle and the filter.

■ NOTE

- The air cleaner uses a dry element. Never apply oil to it.
- Do not run the engine with filter element removed.
- Change the element once a year or every 6th cleaning.

W1045746

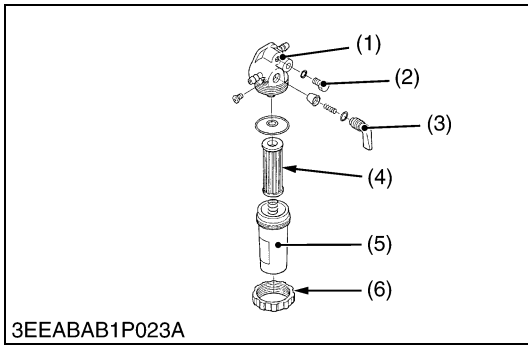

Cleaning Fuel Filter (Element Type only)

1. Close the fuel cock (3).
2. Unscrew the retaining ring (6) and remove the filter cup (5), and rinse the inside with kerosene.
3. Take out the element (4) and dip it in the kerosene to rinse.
4. After cleaning, reassemble the fuel filter, keeping out dust and dirt.
5. Bleed the fuel system.

■ IMPORTANT

- **If dust and dirt enter the fuel, the fuel injection pump and injection nozzle will wear quickly. To prevent this, be sure to clean the fuel filter cup (5) periodically.**

- | | |
|-------------------|--------------------|
| (1) Cock Body | (4) Filter Element |
| (2) Air Vent Plug | (5) Filter Cup |
| (3) Fuel Cock | (6) Retaining Ring |

W1046058

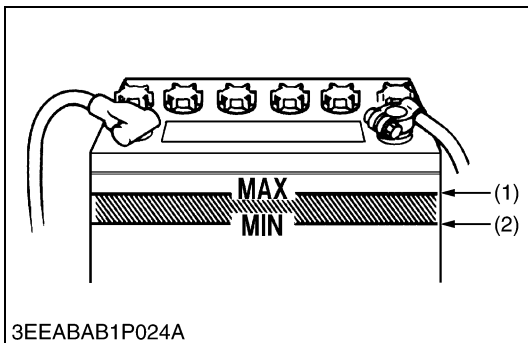

Check of Battery Electrolyte Level

1. Examine the battery electrolyte level.
2. If the level is below the lower level line (2), fill each cell with distilled water until the upper level line.

- | | |
|----------------------|----------------------|
| (1) Upper Level Line | (2) Lower Level Line |
|----------------------|----------------------|

W1047154

[6] CHECK POINT OF EVERY 150 HOURS

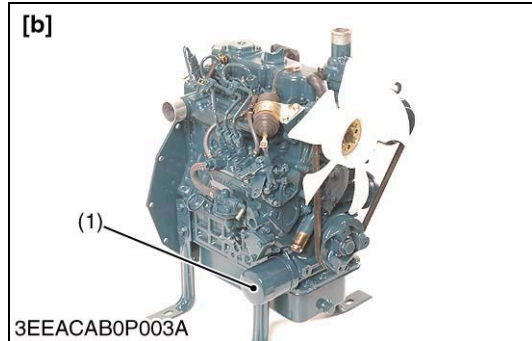

Replacing Oil Filter Cartridge (for Optional Depth Oil Pans)

⚠ CAUTION

- **Be sure to stop the engine before changing filter cartridge.**
1. Remove the oil filter cartridge (1) with the filter wrench.
 2. Apply a slight coat of oil onto the new cartridge gasket.
 3. To install the new cartridge, screw it in by hand. Over tightening may cause deformation of rubber gasket.
 4. After the new cartridge has been replaced, the engine oil normally decrease a little. Thus see that the engine oil does not leak through the seal and be sure to read the oil level on the dipstick. Then, replenish the engine oil up to the specified level.

■ IMPORTANT

- **To prevent serious damage to the engine, replacement element must be highly efficient. Use only a KUBOTA genuine filter or its equivalent.**

(1) Engine Oil Filter Cartridge

[a] Standard Type

[b] One-side Maintenance Type

W1018457

[7] CHECK POINTS OF EVERY 200 HOURS

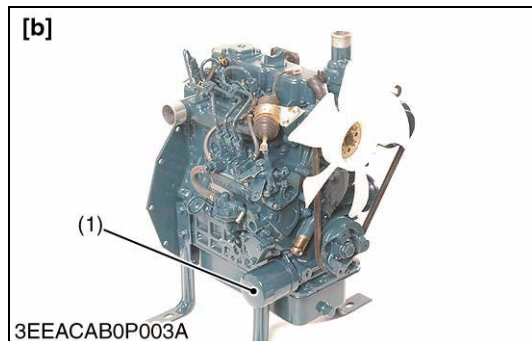

Replacing Oil Filter Cartridge (for Standard Depth Oil Pans)

⚠ CAUTION

- **Be sure to stop the engine before changing filter cartridge.**
1. Remove the oil filter cartridge (1) with the filter wrench.
 2. Apply a slight coat of oil onto the new cartridge gasket.
 3. To install the new cartridge, screw it in by hand. Over tightening may cause deformation of rubber gasket.
 4. After the new cartridge has been replaced, the engine oil normally decrease a little. Thus see that the engine oil does not leak through the seal and be sure to read the oil level on the dipstick. Then, replenish the engine oil up to the specified level.

■ IMPORTANT

- **To prevent serious damage to the engine, replacement element must be highly efficient. Use only a KUBOTA genuine filter or its equivalent.**

(1) Engine Oil Filter Cartridge

[a] Standard Type

[b] One-side Maintenance Type

W1018643

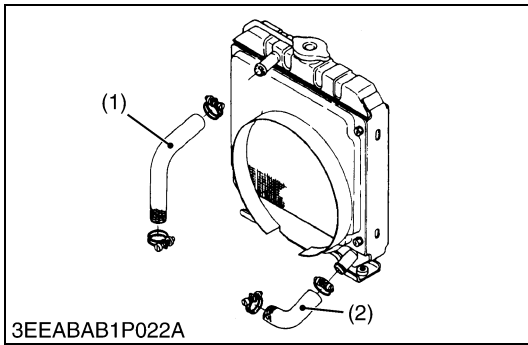

Checking Radiator Hoses and Clamp Bands

1. Check to see if the radiator hoses are properly fixed every 200 hours of operation or every six months, whichever comes first.
2. If the clamp is loose, apply oil to the threads and retighten it securely.
3. The water hose is made of rubber and tends to age. It must be replaced every two years. Also replace the clamp and tighten it securely.

(1) Upper Hose

(2) Lower Hose

W1029518

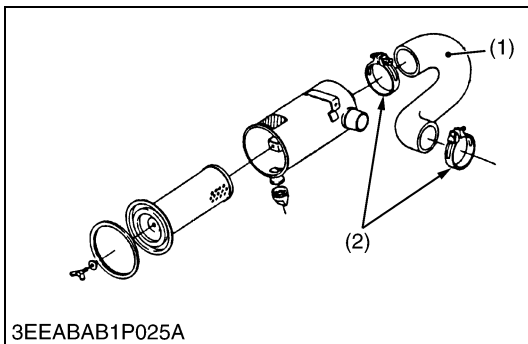

Checking Intake Air Line

1. Check to see if the intake air hose(s) and the breather hose (3) are properly fixed every 200 hours of operation.
2. If the clamp is loose, apply oil to the threads and retighten it securely.
3. The intake air hose(s) and the breather hose are made of rubber and tends to age. It must be changed every two years. Also change the clamp and tighten it securely.

■ IMPORTANT

- To prevent serious damage to the engine, keep out any dust inside the intake air line.

(1) Intake Air Hose

(3) Breather Hose

(2) Clamp

W1029631

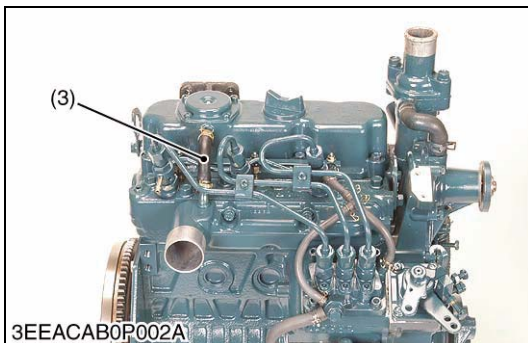

[8] CHECK POINTS OF EVERY 400 HOURS

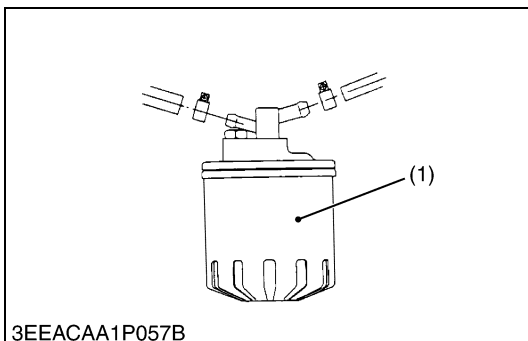

Replacing Fuel Filter Cartridge (Cartridge Type)

Water and dust in fuel are collected in the filter cartridge. So, change the filter cartridge every 400 hours service.

1. Remove the used filter cartridge with filter wrench.
2. Apply a thin film of fuel to the surface of new filter cartridge gasket before screwing on.
3. Then tighten enough by hand.
4. Loosen the air vent plug to let the air out.
5. Start engine and check for fuel leakage.

(1) Fuel Filter Cartridge

W1050548

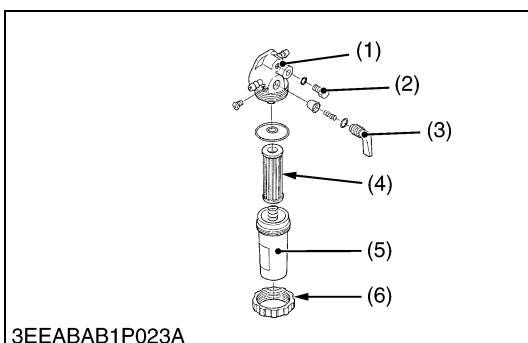

Replacing Fuel Filter Element (Element Type)

1. Close the fuel cock (3).
2. Unscrew the retaining ring (6) and remove the filter cup (5), and rinse the inside with kerosene.
3. Replace the filter element (4).
4. Reassemble the fuel filter, keeping out dust and dirt.
5. Bleed the fuel system.

(1) Cock Body

(4) Filter Element

(2) Air Vent Plug

(5) Filter Cup

(3) Fuel Cock

(6) Retaining Ring

W1050583

[9] CHECK POINTS OF EVERY 500 HOURS

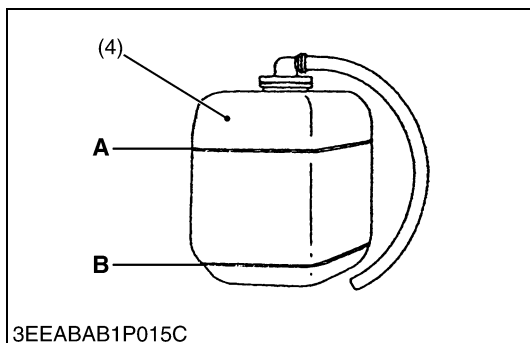
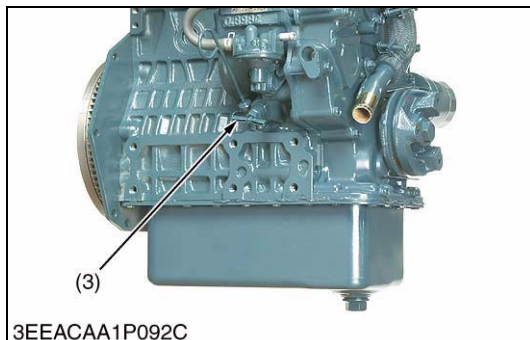
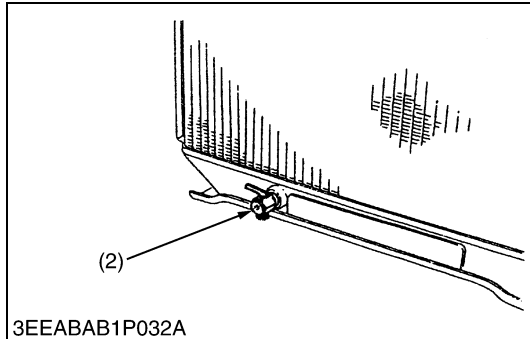
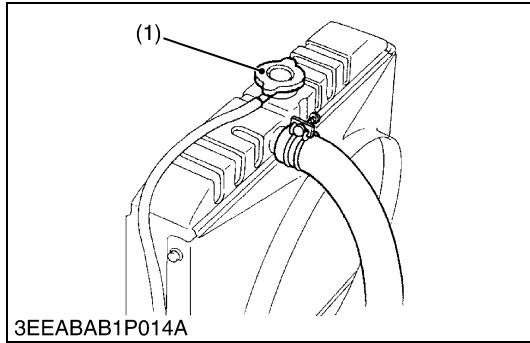

Cleaning Water Jacket and Radiator Interior

⚠ CAUTION

- Do not remove the radiator cap when the engine is hot. Then loosen cap slightly to the stop to relieve any excess pressure before removing cap completely.

1. Stop the engine and let cool down.
2. To drain the coolant, open the radiator drain plug (2) and remove the radiator cap (1). Then radiator cap (1) must be removed to completely drain the coolant. And open the drain cock (3).
3. After all coolant is drained, close the drain plug.
4. Fill with clean water and cooling system cleaner.
5. Follow directions of the cleaner instruction.
6. After flushing, fill with clean water and anti-freeze until the coolant level is just below the port. Install the radiator cap (1) securely.
7. Fill with coolant up to "FULL" (A) mark on the recovery tank (4).
8. Start and operate the engine for few minutes.
9. Stop the engine and let cool. Check coolant level of radiator and recovery tank (4) and add coolant if necessary.

■ IMPORTANT

- Do not start engine without coolant.
- Use clean, fresh, soft water and anti-freeze to fill the radiator and recovery tank.
- When the anti-freeze is mixed with fresh, soft water, the anti-freeze mixing ratio must be less than 50 %.
- Securely tighten radiator cap. If the cap is loose or improperly fitted, water may leak out and the engine could overheat.

- (1) Radiator Cap
 (2) Drain Plug
 (3) Drain Cock
 (4) Recovery Tank

A : Full
 B : Low

W1038102

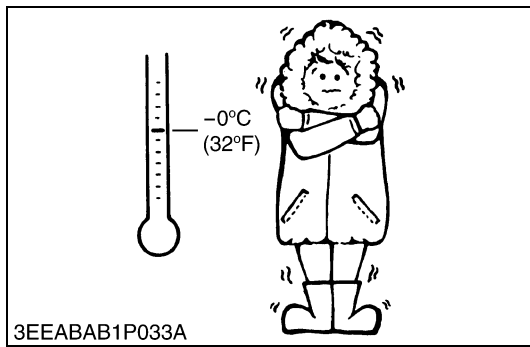

Anti-Freeze

- There are two types of anti-freeze available: use the permanent type (PT) for this engine.
- Before adding anti-freeze for the first time, clean the radiator interior by pouring fresh, soft water and draining it a few times.
- The procedure for mixing water and anti-freeze differs according to the maker of the anti-freeze and the ambient temperature. Basically, it should be referred to SAE J1034 standard, more specifically also to SAE J814c.
- Mix the anti-freeze with fresh, soft water, and then fill into the radiator.

■ IMPORTANT

- **When the anti-freeze is mixed with fresh, soft water, the anti-freeze mixing ratio must be less than 50 %.**

Vol % anti-freeze	Freezing point		Boiling point*	
	°C	°F	°C	°F
40	-24	-11.2	106	222.8
50	-37	-34.6	108	226.4

* At 1.013×100000 Pa (760 mmHg) pressure (atmospheric). A higher boiling point is obtained by using a radiator pressure cap which permits the development of pressure within the cooling system.

■ NOTE

- **The above data represents industrial standards that necessitate a minimum glycol content in the concentrated anti-freeze.**
- **When the coolant level drops due to evaporation, add fresh, soft water only to keep the anti-freeze mixing ratio less than 50 %. In case of leakage, add anti-freeze and fresh, soft water in the specified mixing ratio.**
- **Anti-freeze absorbs moisture. Keep unused anti-freeze in a tightly sealed container.**
- **Do not use radiator cleaning agents when anti-freeze has been added to the coolant.**

(Anti-freeze contains an anti-corrosive agent, which will react with the radiator cleaning agent forming sludge which will affect the engine parts.)

W1039218

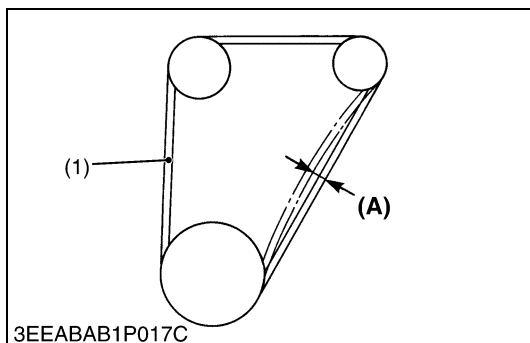

Replacing Fan Belt

1. Remove the alternator.
2. Remove the fan belt (1).
3. Replace new fan belt.
4. Install the alternator.
5. Check the fan belt tension.

Deflection (A)	Factory spec.	7.0 to 9.0 mm / 98 N 0.28 to 0.35 in. / 98 N (10 kgf, 22 lbs)
(1) Fan Belt	(A) Deflection	

(1) Fan Belt

(A) Deflection

W1052220

[10] CHECK POINTS OF EVERY 1 OR 2 MONTHS

Recharging



CAUTION

- When the battery is being activated, hydrogen and oxygen gases in the battery are extremely explosive. Keep open sparks and flames away from the battery at all times, especially when charging the battery.
- When charging battery, remove battery vent plugs.
- When disconnecting the cable from the battery, start with the negative terminal first. When connecting the cable to the battery, start with the positive terminal first.
- Never check battery charge by placing a metal object across the posts.

Use a voltmeter or hydrometer.

1) Slow Charging

1. Add distilled water if the electrolyte level is low. When charging, the amount of electrolyte should be slightly lower than the specified level to prevent overflow.
2. Connect the battery to the charging unit, following the manufacture's instructions.
3. As the electrolyte generates gas while charging, remove all port caps.
4. The electrolyte temperature must not exceed 40 °C (104 °F) during charging.
If it exceed 40 °C (104 °F), decrease the charging amperage or stop charging for a while.
5. When charging several batteries in series, charging at the rate of the smallest battery in the line.

2) Quick Charging

1. Determine the proper charging current and charging time with the tester attached to the quick charger.
2. Determine the proper charging current as 1/1 of the battery capacity. If the battery capacity exceeds 50 Ah, consider 50 A as the maximum.

■ Precaution for Operating a Quick Charger

- Operating with a quick charger differs according to the type. Consult the instruction manual and use accordingly.

W1052658

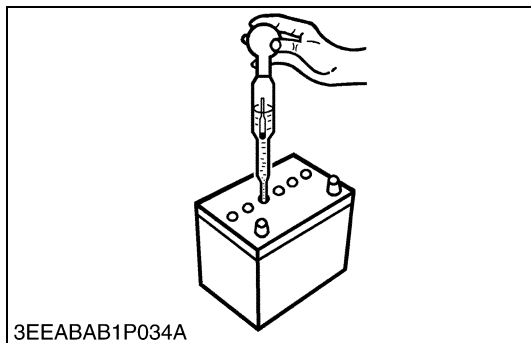

3EEABAB1P034A

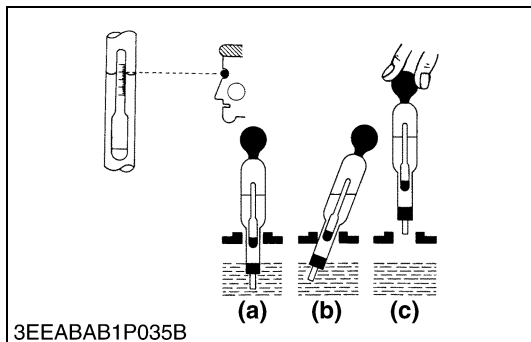

3EEABAB1P035B

Battery Specific Gravity

1. Check the specific gravity of the electrolyte in each cell with a hydrometer.
2. When the electrolyte temperature differs from that at which the hydrometer was calibrated, correct the specific gravity reading following the formula mentioned in **(Reference)**.
3. If the specific gravity is less than 1.215 (after it is corrected for temperature), charge or replace the battery.
4. If the specific gravity differs between any two cells by more than 0.05, replace the battery.

NOTE

- **Hold the hydrometer tube vertical without removing it from the electrolyte.**
- **Do not suck too much electrolyte into the tube.**
- **Allow the float to move freely and hold the hydrometer at eye level.**
- **The hydrometer reading must be taken at the highest electrolyte level.**

(Reference)

- Specific gravity slightly varies with temperature. To be exact, the specific gravity decreases by 0.0007 with an increase of 1 °C (0.0004 with an increase of 1 °F) in temperature, and increases by 0.0007 with a decreases of 1 °C (0.0004 with a decrease of 1 °F).

Therefore, using 20 °C (68 °F) as a reference, the specific gravity reading must be corrected by the following formula :

- Specific gravity at 20 °C = Measured value + 0.0007 × (electrolyte temperature – 20 °C)
- Specific gravity at 68 °F = Measured value + 0.0004 × (electrolyte temperature – 68 °F)

Specific Gravity	State of Charge
1.260 Sp. Gr.	100 % Charged
1.230 Sp. Gr.	75 % Charged
1.200 Sp. Gr.	50 % Charged
1.170 Sp. Gr.	25 % Charged
1.140 Sp. Gr.	Very Little Useful Capacity
1.110 Sp. Gr.	Discharged

At an electrolyte temperature of 20 °C (68 °F)

(a) Good

(b) Bad

(c) Bad

W1012763

[11] CHECK POINT OF EVERY YEAR

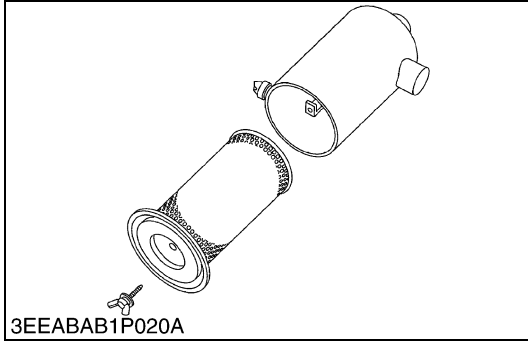

Replacing Air Cleaner Element

1. Remove used air cleaner element.
2. Replace new air cleaner element.

■ NOTE

- The air cleaner uses a dry element. Never apply oil to it.
- Do not run the engine with filter element removed.

W1020554

[12] CHECK POINT OF EVERY 800 HOURS

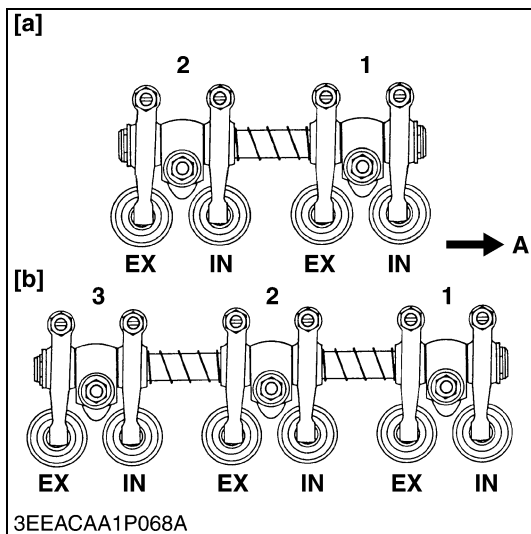
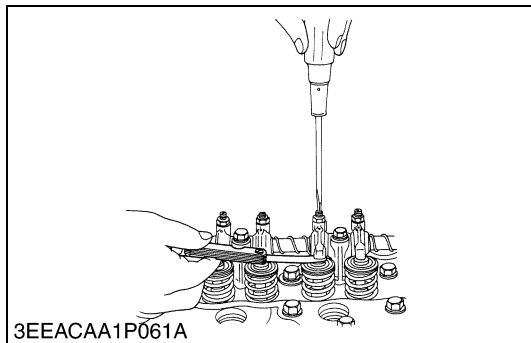
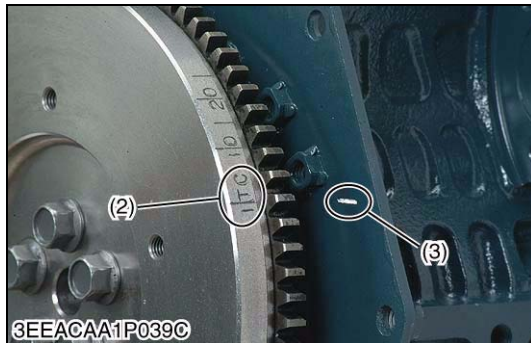
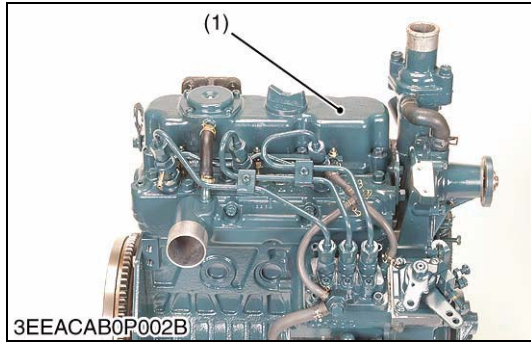

Checking Valve Clearance

■ IMPORTANT

- Valve clearance must be checked and adjusted when engine is cold.

1. Remove the cylinder head cover (1) and the glow plugs.
2. Align the "1TC" mark (2) on the flywheel and alignment mark (3) on the rear end plate so that the No. 1 piston comes to the compression top dead center.
3. Check the following valve clearance marked with "★" using a feeler gauge.
4. If the clearance is not within the factory specifications, adjust with the adjusting screw.
5. Then turn the flywheel 6.28 rad (360 °), and align the "1TC" mark (2) on the flywheel and alignment mark (3) on the rear end plate so that the No. 1 piston comes to the overlap position.
6. Check the following valve clearance marked with "☆" using a feeler gauge.
7. If the clearance is not within the factory specifications, adjust with the adjusting screw.

Number of cylinders Valve arrangement	Z482-E2B Z602-E2B		D662-E2B D722-E2B D782-E2B D902-E2B	
	Intake valve	Exhaust valve	Intake valve	Exhaust valve
Adjustable cylinder location of piston				
No. 1	★	★	★	★
No. 2	☆	★	☆	★
No. 3	—	—	★	☆

★ : When No. 1 piston is at the compression top dead center position.

☆ : When No. 1 piston is at the overlap position.

Intake and exhaust valve clearance (cold)	Factory spec.	0.145 to 0.185 mm 0.00571 to 0.00728 in.
---	---------------	---

■ NOTE

- The sequence of cylinder numbers is given as No. 1, No. 2 and No. 3 starting from the gear case side.
- After adjusting the valve clearance, secure the adjusting screw with the lock nut.

- (1) Cylinder Head Cover
- (2) "1TC" Mark
- (3) Alignment Mark

A : Gear Case Side

[a] Z482-E2B, Z602-E2B

[b] D662-E2B, D722-E2B,
D782-E2B, D902-E2B

W10113200

[13] CHECK POINTS OF EVERY 1500 HOURS

⚠ CAUTION

- Check the injection pressure and condition after confirming that there is nobody standing in the direction the fume goes.
- If the fume from the nozzle directly contacts the human body, cells may be destroyed and blood poisoning may be caused.

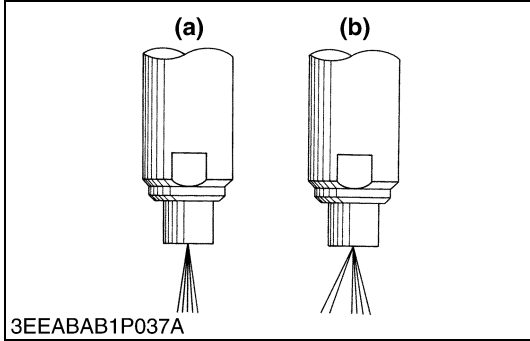

Nozzle Spraying Condition

1. Set the injection nozzle to a nozzle tester, and check the nozzle spraying condition.
2. If the spraying condition is defective, replace the nozzle piece.

(a) Good

(b) Bad

W10411400

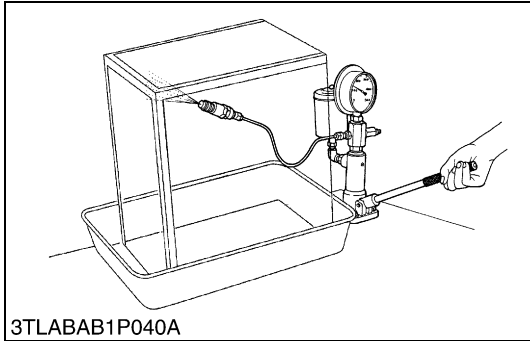

Fuel Injection Pressure

1. Set the injection nozzle to a nozzle tester.
2. Slowly move the tester handle to measure the pressure at which fuel begins jetting out from the nozzle.
3. If the measurement is not within the factory specifications, replace the adjusting washer (1) in the nozzle holder to adjust it.

(Reference)

- Pressure variation with 0.025 mm (0.0010 in.) difference of adjusting washer thickness.
Approx. 588 kPa (6.0 kgf/cm², 85 psi)

Fuel injection pressure	Factory spec.	13.73 to 14.71 MPa 140 to 150 kgf/cm ² 1991 to 2134 psi
-------------------------	---------------	--

(1) Adjusting Washer

W10182100

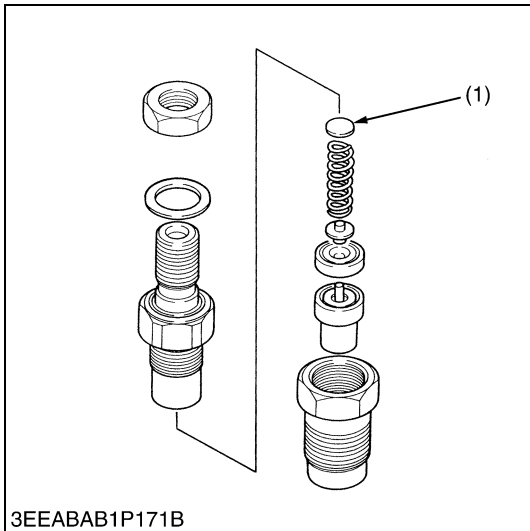

Nozzle Valve Seat Tightness

1. Set the injection nozzle to a nozzle tester.
2. Raise the fuel pressure, and keep at 12.75 MPa (130 kgf/cm², 1849 psi) for 10 seconds.
3. If any fuel leak is found, replace the nozzle piece.

Valve seat tightness	Factory spec.	No fuel leak at 12.75 MPa 130 kgf/cm ² 1849 psi
----------------------	---------------	---

W10412730

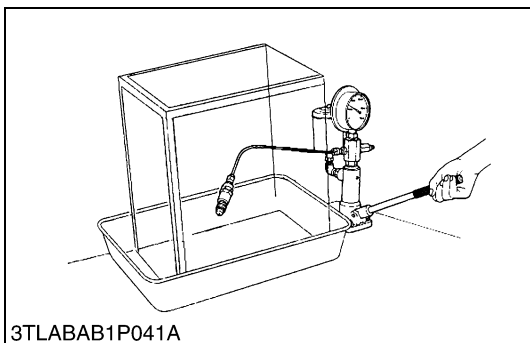

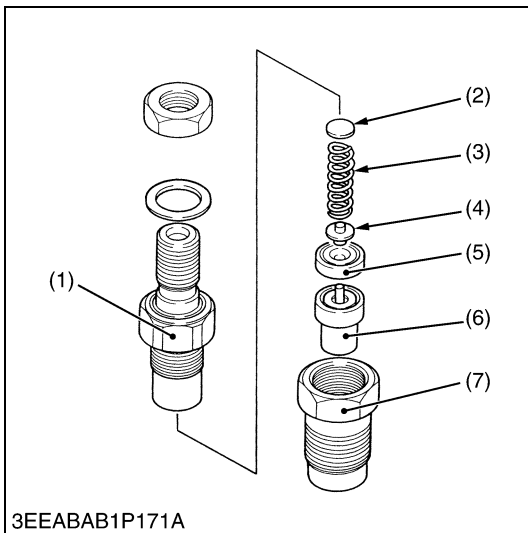

Nozzle Holder

1. Secure the nozzle retaining nut (7) with a vise.
2. Remove the nozzle holder (1), and take out parts inside.

(When reassembling)

- Assemble the nozzle in clean fuel oil.
- Install the push rod (4), noting its direction.
- After assembling the nozzle, be sure to adjust the fuel injection pressure.

Tightening torque	Nozzle holder	34.3 to 39.2 N·m 3.5 to 4.0 kgf·m 25.3 to 28.9 ft-lbs
	Overflow pipe retaining nut	19.6 to 24.5 N·m 2.0 to 2.5 kgf·m 14.5 to 18.1 ft-lbs
	Nozzle holder assembly	49.0 to 68.6 N·m 5.0 to 7.0 kgf·m 36.2 to 50.6 ft-lbs

- (1) Nozzle Holder
- (2) Adjusting Washer
- (3) Nozzle Spring
- (4) Push Rod

- (5) Distance Piece
- (6) Nozzle Piece
- (7) Nozzle Retaining Nut

W1018491

[14] CHECK POINTS OF EVERY 3000 HOURS

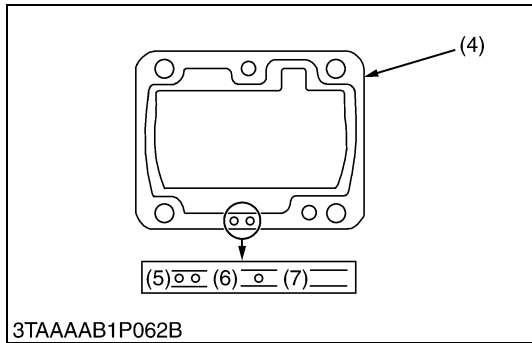
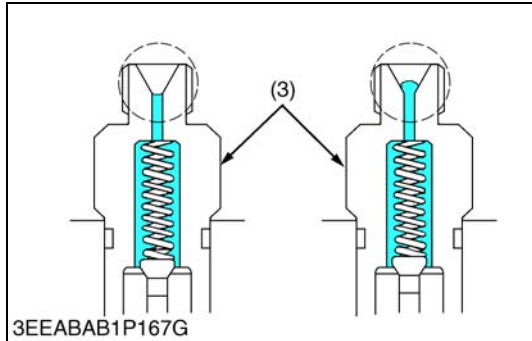
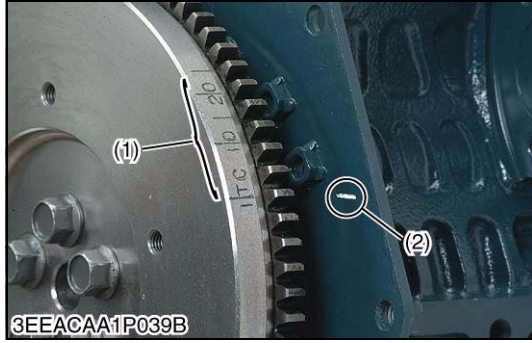

Injection Timing

1. Remove the injection pipes.
2. Remove the engine stop solenoid.
3. Turn the flywheel counterclockwise (viewed from flywheel side) until the fuel fills up to the hole of the delivery valve holder (3) for No. 1 cylinder.
4. After the fuel fills up to the hole of the delivery valve holder for No. 1 cylinder, turn back (clockwise) the flywheel around 1.57 rad (90°).
5. Turn the flywheel counterclockwise to set at around 0.44 rad (25°) before T.D.C..
6. Slowly turn the flywheel counterclockwise and stop turning when the fuel begins to come up, to get the present injection timing.
7. Check to see the degree on flywheel.
The flywheel has mark "1TC", "10" and "20" for the crank angle before the top dead center of No. 1 cylinder.
8. Check to see if the timing angle on the flywheel is aligned with the alignment mark (2).
9. If injection timing is out of adjustment, readjust the timing with shims.

Z482/D662/D722-E2B (3600 min⁻¹ (rpm) spec.)

Injection timing	Factory spec.	0.33 to 0.37 rad (19 to 21°) before T.D.C.
------------------	---------------	--

D782-E2B (3200 min⁻¹ (rpm) spec.)

Injection timing	Factory spec.	0.28 to 0.31 rad (16 to 18°) before T.D.C.
------------------	---------------	--

Z602/D902-E2B (3200 min⁻¹ (rpm) spec.)

Injection timing	Factory spec.	0.30 to 0.33 rad (17 to 19°) before T.D.C.
------------------	---------------	--

Z602/D902-E2B (3600 min⁻¹ (rpm) spec.)

Injection timing	Factory spec.	0.33 to 0.37 rad (19 to 21°) before T.D.C.
------------------	---------------	--

- | | |
|-----------------------------------|---|
| (1) Timing Line | (5) Two-holes : 0.20 mm (0.0079 in.) |
| (2) Alignment Mark | (6) One-hole : 0.25 mm (0.0098 in.) |
| (3) Delivery Valve Holder | (7) Without hole : 0.30 mm (0.0118 in.) |
| (4) Shim (Soft Metal Gasket Shim) | |

W1023147

Injection Timing (Continued)**NOTE**

- The sealant is applied to both sides of the shims (soft metal gasket shim). The liquid gasket is not required for assembling.
- Shims are available in thickness of 0.20 mm (0.0079 in.), 0.25 mm (0.0098 in.) and 0.30 mm (0.0118 in.). Combine these shims for adjustments.
- Addition or reduction of shim (0.05 mm, 0.0020 in.) delays or advances the injection timing by approx. 0.0087 rad (0.5 °).
- In disassembling and replacing the injection pump, be sure to use the same number of new shims with the same thickness.
- Refer to figure of the shim to check the thickness of the shims.
- The injection timing might be changed by the application.

(Reference)

- Injection Timing Map (before T.D.C.)

Rated Speed Specification (min ⁻¹ (rpm))	Model		
	Z482-E2B D662-E2B D722-E2B	D782-E2B	Z602-E2B D902-E2B
3600 to 3301	0.33 to 0.37 rad (19 to 21 °)	–	0.33 to 0.37 rad (19 to 21 °)
3300 to 3001	0.31 to 0.35 rad (18 to 20 °)	0.28 to 0.31 rad (16 to 18 °)	0.30 to 0.33 rad (17 to 19 °)
3000 to 2501	0.30 to 0.33 rad (17 to 19 °)	0.28 to 0.31 rad (16 to 18 °)	0.28 to 0.31 rad (16 to 18 °)
2500 to 2001	0.26 to 0.30 rad (15 to 17 °)	0.24 to 0.28 rad (14 to 16 °)	0.24 to 0.28 rad (14 to 16 °)
Under 2000	0.23 to 0.26 rad (13 to 15 °)	0.23 to 0.26 rad (13 to 15 °)	0.23 to 0.26 rad (13 to 15 °)

W1022861

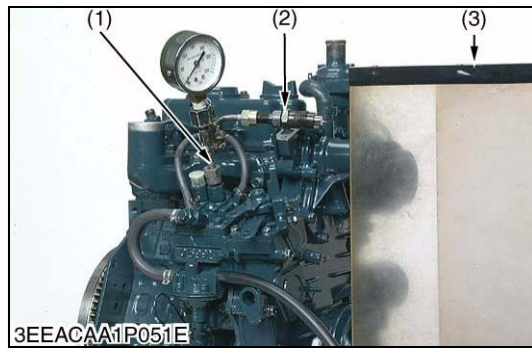

Checking Injection Pump

(Fuel Tightness of Pump Element)

1. Remove the engine stop solenoid.
2. Remove the injection pipes and glow plugs.
3. Install the injection pump pressure tester to the injection pump.
4. Install the injection nozzle (2) jetted with the proper injection pressure to the injection pump pressure tester (1). (Refer to the photo.)
5. Set the speed control lever to the maximum speed position.
6. Run the starter to increase the pressure.
7. If the pressure can not reach the allowable limit, replace the pump with new one or repair with a Kubota-authorized pump service shop.

(Fuel Tightness of Delivery Valve)

1. Remove the engine stop solenoid.
2. Remove the injection pipes and glow plugs.
3. Set a pressure tester to the fuel injection pump.
4. Install the injection nozzle (2) jetted with the proper injection pressure to the injection pump pressure tester (1).
5. Run the starter to increase the pressure.
6. Stop the starter when the fuel jets from the injection nozzle. After that, turn the flywheel by hands and raise the pressure to approx. 13.73 MPa (140 kgf/cm², 1991 psi).
7. Now turn the flywheel back about half a turn (to keep the plunger free). Maintain the flywheel at this position and clock the time taken for the pressure to drop from 13.73 to 12.75 MPa (from 140 to 130 kgf/cm², from 1991 to 1849 psi).
8. Measure the time needed to decrease the pressure from 13.73 to 12.75 MPa (140 to 130 kgf/cm², 1991 to 1849 psi).
9. If the measurement is less than allowable limit, replace the pump with new one or repair with a Kubota-authorized pump service shop.

Fuel tightness of pump element	Allowable limit	13.73 MPa 140 kgf/cm ² 1991 psi
Fuel tightness of delivery valve	Factory spec.	10 seconds 13.73 → 12.75 MPa 140 → 130 kgf/cm ² 1991 → 1849 psi
	Allowable limit	5 seconds 13.73 → 12.75 MPa 140 → 130 kgf/cm ² 1991 → 1849 psi

■ NOTE

- **Never try to disassemble the injection pump assembly. For repairs, you are strongly requested to contact a Kubota-authorized pump service shop.**

- (1) Injection Pump Pressure Tester (3) Protection Cover for Jetted Fuel
(2) Injection Nozzle

W1022357

[15] CHECK POINTS OF EVERY 2 YEARS

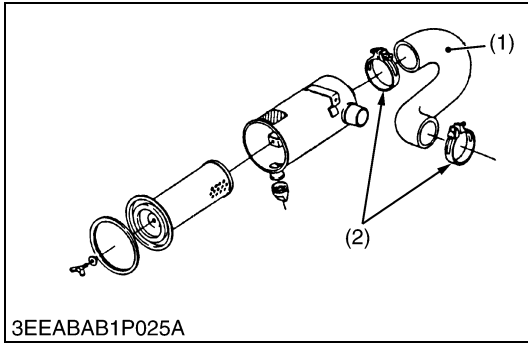

Replacing Intake Air Line

1. Loosen the clamp (2).
2. Remove the intake air hose (1) and clamp (2).
3. Replace new intake air hose (1) and new clamp (2).
4. Tighten the clamp (2).

■ NOTE

- To prevent serious damage to the engine, keep out any dust inside the intake air line.

(1) Intake Air Hose

(2) Clamp

W1023867

Replacing Battery

⚠ CAUTION

- When the battery is being activated, hydrogen and oxygen gases in the battery are extremely explosive. Keep open sparks and flames away from the battery at all times, especially when charging the battery.
- When charging battery, remove battery vent plugs.
- When disconnecting the cable from the battery, start with the negative terminal first. When connecting the cable to the battery, start with the positive terminal first.
- Never check battery charge by placing a metal object across the posts.

1. Disconnect the negative terminal and positive terminal.
2. Remove the battery holder.
3. Remove the used battery.
4. Replace the new battery.
5. Tighten the battery holder.
6. Connect the positive terminal.
7. Connect the negative terminal.

W1023996

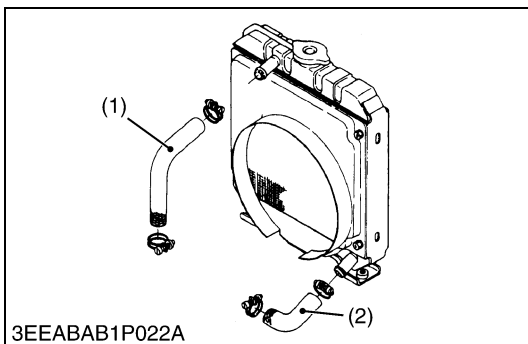

Replacing Radiator Hoses and Clamp Bands

⚠ CAUTION

- Do not remove the radiator cap when the engine is hot. Then loosen cap slightly to the stop to relieve any excess pressure before removing cap completely.

1. Drain the coolant.
2. Loosen the clamp bands.
3. Remove the upper hose (1) and lower hose (2).
4. Replace new upper / lower hose (1), (2) and clamp bands.
5. Tighten the clamp bands.
6. Fill with clean water and anti-freeze until the coolant level is just below the port. Install the radiator cap securely.

(1) Upper Hose

(2) Lower Hose

W1024178

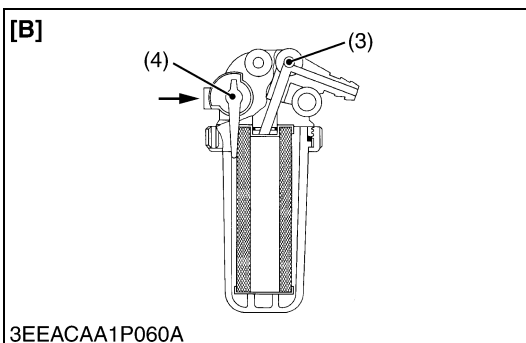
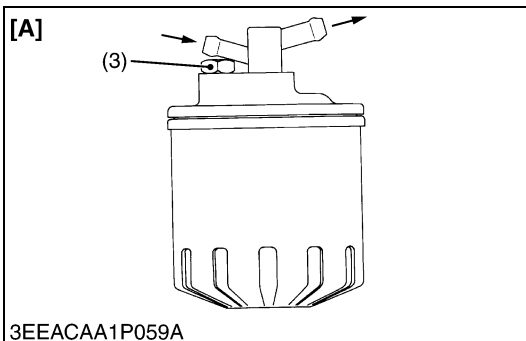
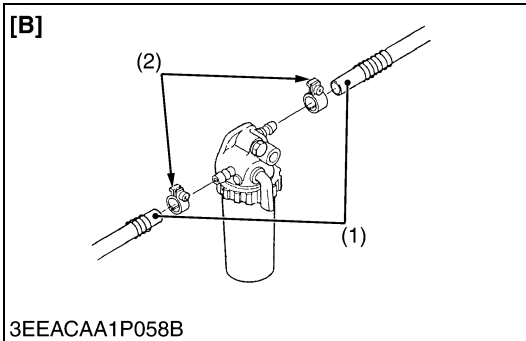
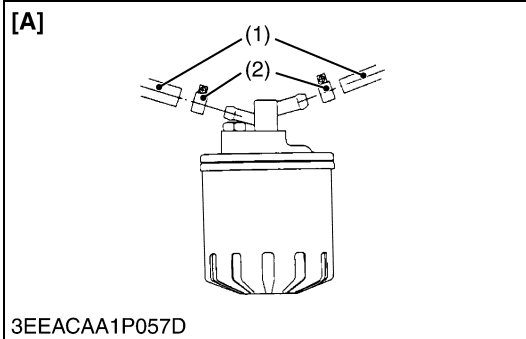

Replacing Fuel Hoses and Clamp Bands

1. Loosen the clamp (2) and remove the fuel hose (1).
2. Replace new fuel hose (1) and new clamp (2).
3. Tighten the clamp (2).

⚠ CAUTION

- Stop the engine when attempting the check and change prescribed above.

(When bleeding fuel system)

1. Fill the tank with fuel and open the cock (4).
2. Loosen the air vent plug (3) of the fuel filter a few turns.
3. Screw back the plug when bubbles do not come up any more.
4. Open the air vent cock on top of the fuel injection pump.
5. If equipped electrical fuel feed pump, turn the key to **AC** position and pump the fuel up for 10 to 15 seconds.
If equipped mechanical fuel feed pump, set the stop lever on stop position and crank the engine for 10 to 15 seconds.
6. Close securely the air vent cock after air bleeding.

■ NOTE

- Always keep the air vent cock on the fuel injection pump closed except when air is vented, or it may cause the engine to stop.

- (1) Fuel Hose
(2) Clamp
(3) Air Vent Plug
(4) Fuel Cock

- [A] Cartridge Type
[B] Element Type

W1024305

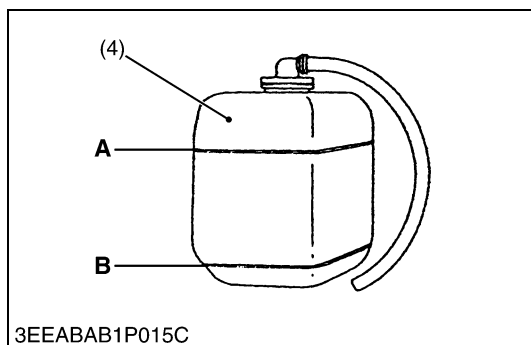
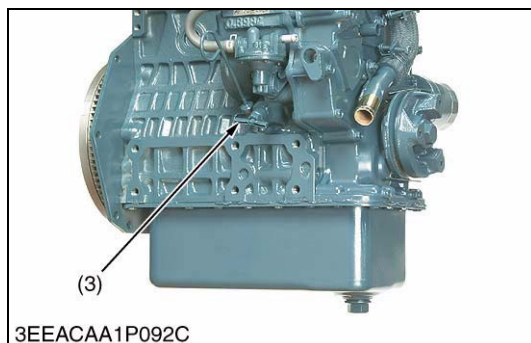
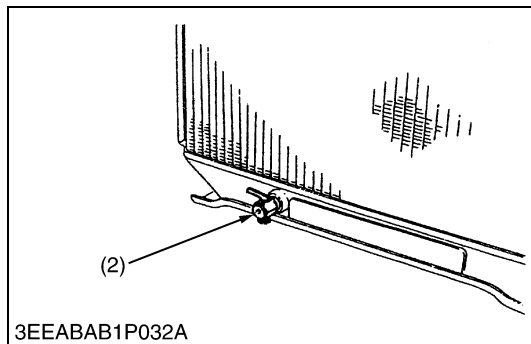
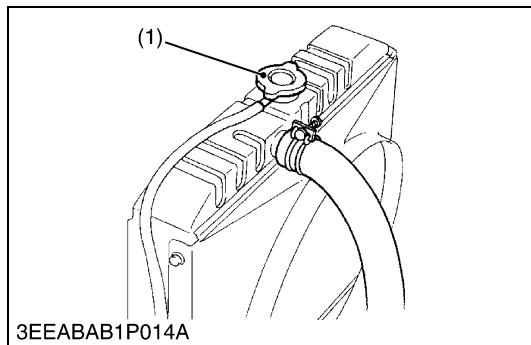

Cleaning Water Jacket and Radiator Interior

⚠ CAUTION

- **Do not remove the radiator cap when the engine is hot. Then loosen cap slightly to the stop to relieve any excess pressure before removing cap completely.**

1. Stop the engine and let cool down.
2. To drain the coolant, open the radiator drain plug (2) and remove the radiator cap (1). Then radiator cap (1) must be removed to completely drain the coolant. And open the drain cock (3).
3. After all coolant is drained, close the drain plug.
4. Fill with clean water and cooling system cleaner.
5. Follow directions of the cleaner instruction.
6. After flushing, fill with clean water and anti-freeze until the coolant level is just below the port. Install the radiator cap (1) securely.
7. Fill with coolant up to "FULL" (A) mark on the recovery tank (4).
8. Start and operate the engine for few minutes.
9. Stop the engine and let cool. Check coolant level of radiator and recovery tank (4) and add coolant if necessary.

■ IMPORTANT

- **Do not start engine without coolant.**
- **Use clean, fresh, soft water and anti-freeze to fill the radiator and recovery tank.**
- **When the anti-freeze is mixed with fresh, soft water, the anti-freeze mixing ratio must be less than 50 %.**
- **Securely tighten radiator cap. If the cap is loose or improperly fitted, water may leak out and the engine could overheat.**

- (1) Radiator Cap
 (2) Drain Plug
 (3) Drain Cock
 (4) Recovery Tank

A : Full
 B : Low

W1028063

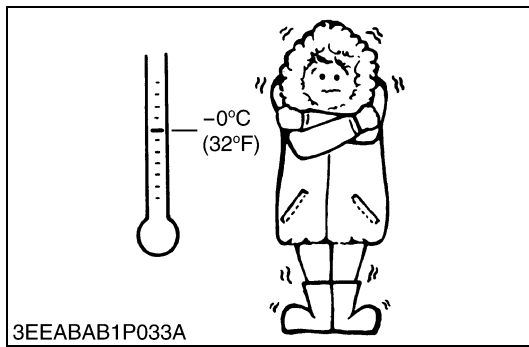

Changing Radiator Coolant (L.L.C.) (Continued)

(Anti-freeze)

- There are two types of anti-freeze available: use the permanent type (PT) for this engine.
- Before adding anti-freeze for the first time, clean the radiator interior by pouring fresh, soft water and draining it a few times.
- The procedure for mixing water and anti-freeze differs according to the maker of the anti-freeze and the ambient temperature. Basically, it should be referred to SAE J1034 standard, more specifically also to SAE J814c.
- Mix the anti-freeze with fresh, soft water, and then fill into the radiator.

■ IMPORTANT

- **When the anti-freeze is mixed with fresh, soft water, the anti-freeze mixing ratio must be less than 50 %.**

Vol % anti-freeze	Freezing point		Boiling point*	
	°C	°F	°C	°F
40	-24	-11.2	106	222.8
50	-37	-34.6	108	226.4

* At 1.013×100000 Pa (760 mmHg) pressure (atmospheric). A higher boiling point is obtained by using a radiator pressure cap which permits the development of pressure within the cooling system.

■ NOTE

- **The above data represents industrial standards that necessitate a minimum glycol content in the concentrated anti-freeze.**
- **When the coolant level drops due to evaporation, add fresh, soft water only to keep the anti-freeze mixing ratio less than 50 %. In case of leakage, add anti-freeze and fresh, soft water in the specified mixing ratio.**
- **Anti-freeze absorbs moisture. Keep unused anti-freeze in a tightly sealed container.**
- **Do not use radiator cleaning agents when anti-freeze has been added to the coolant.**
(Anti-freeze contains an anti-corrosive agent, which will react with the radiator cleaning agent forming sludge which will affect the engine parts.)

W1024852

5. SPECIAL TOOLS

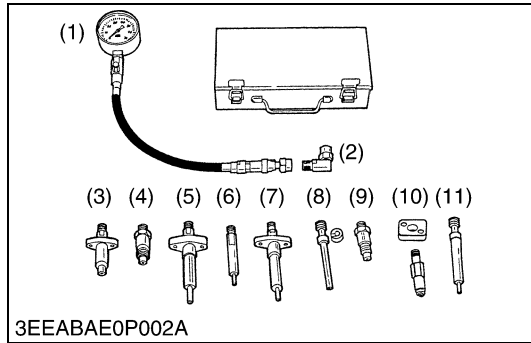

Diesel Engine Compression Tester (for Injection Nozzle)

Code No: 07909-30208 (Assembly) 07909-31251 (G)
 07909-30934 (A to F) 07909-31271 (I)
 07909-31211 (E and F) 07909-31281 (J)
 07909-31231 (H)

Application: Use to measure diesel engine compression and diagnosis of need for major overhaul.

- | | |
|---------------|----------------|
| (1) Gauge | (7) Adaptor F |
| (2) L Joint | (8) Adaptor G |
| (3) Adaptor A | (9) Adaptor H |
| (4) Adaptor B | (10) Adaptor I |
| (5) Adaptor C | (11) Adaptor J |
| (6) Adaptor E | |

W1024200

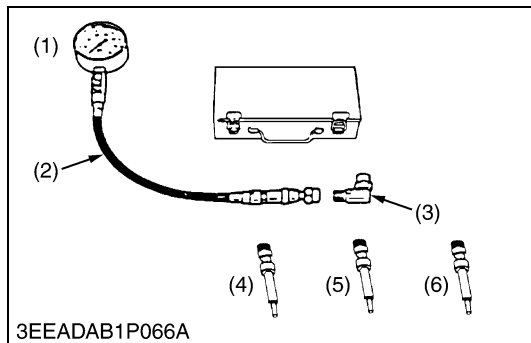

Diesel Engine Compression Tester (for Glow Plug)

Code No: 07909-39081 (Assembly) 07909-31301 (L)
 07909-31291 (K) 07909-31311 (M)

Application: Use to measure diesel engine compression and diagnosis of need for major overhaul.

- | | |
|-------------------|---------------|
| (1) Gauge | (4) Adaptor K |
| (2) Hose Assembly | (5) Adaptor L |
| (3) L Joint | (6) Adaptor M |

W1025289

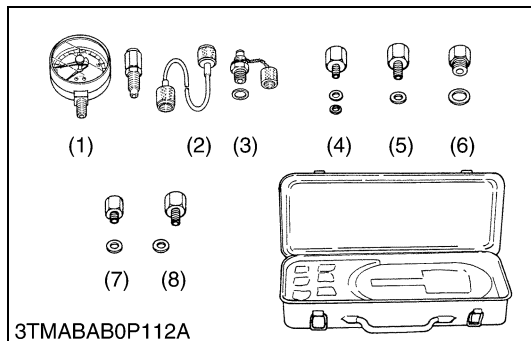

Oil Pressure Tester

Code No: 07916-32032

Application: Use to measure lubricating oil pressure.

- | | |
|--------------------|---------------|
| (1) Gauge | (5) Adaptor 2 |
| (2) Cable | (6) Adaptor 3 |
| (3) Threaded Joint | (7) Adaptor 4 |
| (4) Adaptor 1 | (8) Adaptor 5 |

W1024318

■ NOTE

- The following special tools are not provided, so make them referring to the figure.

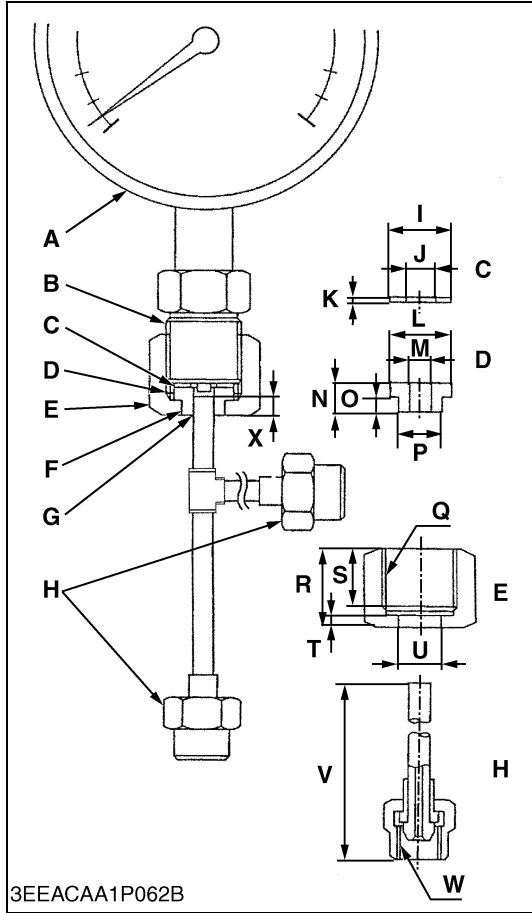

Injection Pump Pressure Tester

Application: Use to check fuel tightness of injection pumps.

A	Pressure gauge full scale : More than 29.4 MPa (300 kgf/cm ² , 4267 psi)
B	PF 1/2
C	Copper gasket
D	Flange (Material Steel)
E	Hex. nut 27 mm (1.06 in.) across the plat
F	Adhesive application
G	Fillet welding on the enter circumference
H	Retaining nut
I	17 mm dia. (0.67 in. dia.)
J	8 mm dia. (0.31 in. dia.)
K	1.0 mm (0.039 in.)
L	17 mm dia. (0.67 in. dia.)
M	6.10 to 6.20 mm dia. (0.2402 to 0.2441 in. dia.)
N	8 mm (0.31 in.)
O	4 mm (0.16 in.)
P	11.97 to 11.99 mm dia. (0.4713 to 0.4720 in. dia.)
Q	PF 1/2
R	23 mm (0.91 in.)
S	17 mm (0.67 in.)
T	4 mm (0.16 in.)
U	12.00 to 12.02 mm dia. (0.4724 to 0.4732 in. dia.)
V	100 mm (3.94 in.)
W	M12 × P1.5
X	5 mm (0.20 in.)

W10252400

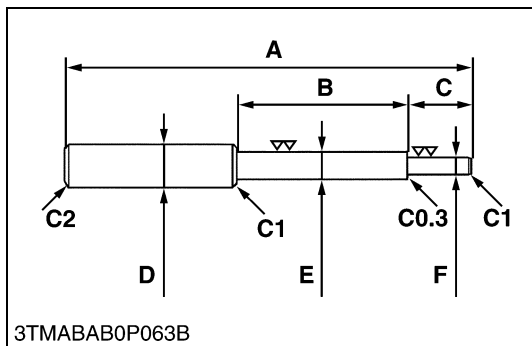

Valve Guide Replacing Tool

Application: Use to press out and press fit the valve guide.

A	220 mm (8.66 in.)
B	80 mm (3.15 in.)
C	40 mm (1.58 in.)
D	20 mm dia. (0.79 in. dia.)
E	9.96 to 9.98 mm dia. (0.3921 to 0.3929 in. dia.)
F	5.5 to 5.7 mm dia. (0.2165 to 0.2244 in. dia.)
G	25 mm dia. (0.98 in. dia.)
H	6.0 to 6.1 mm dia. (0.236 to 0.240 in. dia.)
I	5 mm (0.197 in.)
J	18 mm dia. (0.71 in. dia.)
K	10.6 to 10.7 mm dia. (0.417 to 0.421 in. dia.)
L	6.9 to 7.1 mm (0.272 to 0.280 in.)
C1	Chamfer 1.0 mm (0.039 in.)
C2	Chamfer 2.0 mm (0.079 in.)
C0.3	Chamfer 0.3 mm (0.012 in.)

W10250170

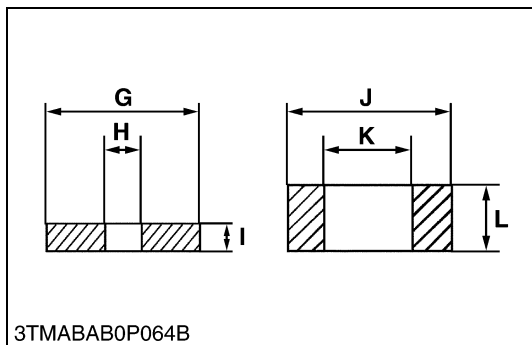

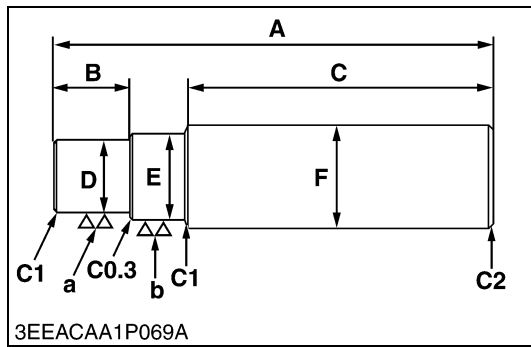

Bushing Replacing Tool

Application: Use to press out and press fit the bushing.

1. For small end bushing

A	145 mm (5.71 in.)
B	20 mm (0.79 in.)
C	100 mm (3.94 in.)
D	19.90 to 19.95 mm dia. (0.7835 to 0.7854 in. dia.)
E	21.90 to 21.95 mm dia. (0.8622 to 0.8642 in. dia.)
F	25 mm dia. (0.98 in. dia.)
C1	Chamfer 1.0 mm (0.039 in.)
C2	Chamfer 2.0 mm (0.079 in.)
C0.3	Chamfer 0.3 mm (0.012 in.)
a	6.3 μm (248 μin.)
b	6.3 μm (248 μin.)

2. For idle gear bushing

A	150 mm (5.91 in.)
B	23 mm (0.91 in.)
C	100 mm (3.94 in.)
D	19.90 to 19.95 mm dia. (0.7835 to 0.7854 in. dia.)
E	21.90 to 21.95 mm dia. (0.8622 to 0.8642 in. dia.)
F	25 mm dia. (0.98 in. dia.)
C1	Chamfer 1.0 mm (0.039 in.)
C2	Chamfer 2.0 mm (0.079 in.)
C0.3	Chamfer 0.3 mm (0.012 in.)
a	6.3 μm (248 μin.)
b	6.3 μm (248 μin.)

W12358870

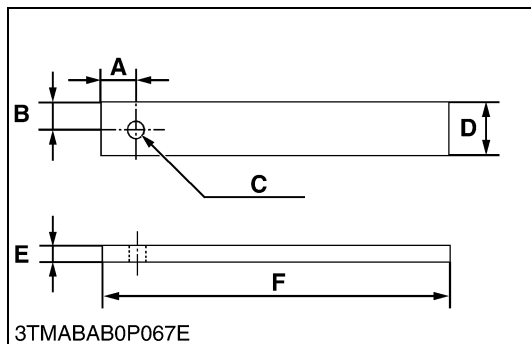

Flywheel Stopper

Application: Use to loosen and tighten the flywheel screw.

A	20 mm (0.79 in.)
B	15 mm (0.59 in.)
C	10 mm dia. (0.39 in. dia.)
D	30 mm (1.18 in.)
E	8 mm (0.31 in.)
F	200 mm (7.87 in.)

W10259480

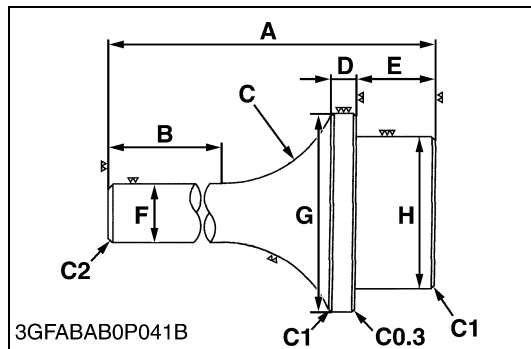

Crankshaft Bearing 1 Replacing Tool

Application: Use to press out and press fit the crankshaft bearing 1.

[Press Out]

A	135 mm (5.31 in.)
B	72 mm (2.83 in.)
C	40 mm radius (1.57 in. radius)
D	10 mm (0.39 in.)
E	22 mm (0.87 in.)
F	20 mm dia. (0.79 in. dia.)
G	47.90 to 47.95 mm dia. (1.8858 to 1.8878 in. dia.)
H	43.90 to 43.95 mm dia. (1.7283 to 1.7303 in. dia.)
C1	Chamfer 1.0 mm (0.039 in.)
C2	Chamfer 2.0 mm (0.079 in.)
C0.3	Chamfer 0.3 mm (0.012 in.)

[Press Fit] for Z482/D662/D722/D782-E2B

A	130 mm (5.12 in.)
B	72 mm (2.83 in.)
C	40 mm radius (1.57 in. radius)
D	9 mm (0.35 in.)
E	24 mm (0.95 in.)
F	20 mm dia. (0.79 in. dia.)
G	68 mm dia. (2.68 in. dia.)
H	39.90 to 39.95 mm dia. (1.5709 to 1.5728 in. dia.)
C1	Chamfer 1.0 mm (0.039 in.)
C2	Chamfer 2.0 mm (0.079 in.)
C0.3	Chamfer 0.3 mm (0.012 in.)

[Press Fit] for Z602/D902-E2B

A	130 mm (5.12 in.)
B	72 mm (2.83 in.)
C	40 mm radius (1.57 in. radius)
D	9 mm (0.35 in.)
E	24 mm (0.95 in.)
F	20 mm dia. (0.79 in. dia.)
G	68 mm dia. (2.68 in. dia.)
H	43.90 to 43.95 mm dia. (1.7283 to 1.7303 in. dia.)
C1	Chamfer 1.0 mm (0.039 in.)
C2	Chamfer 2.0 mm (0.079 in.)
C0.3	Chamfer 0.3 mm (0.012 in.)

W10261390

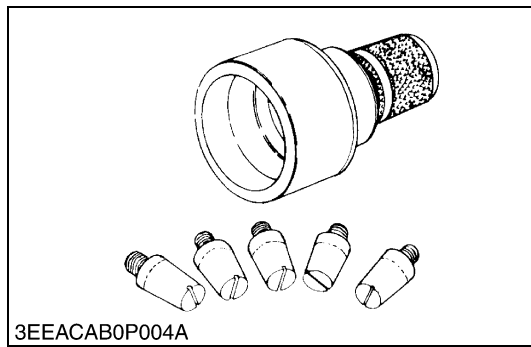

Crank Sleeve Setter (for Z482/D662/D722/D782-E2B)

Application: Use to fix the crankshaft sleeve.

(1) Auxiliary Socket for Pushing

A	130 mm (5.12 in.)
B	112 mm (4.41 in.)
C	107 mm (4.21 in.)
D	82 mm (3.23 in.)
E	72 mm (2.83 in.)
F	67 mm (2.64 in.)
G	47 mm (1.85 in.)
H	37.0 to 37.2 mm (1.457 to 1.465 in.)
I	17 mm (0.67 in.)
J	5 mm dia. (0.20 in. dia.)
K	52 mm dia. (2.05 in. dia.)
L	40 mm dia. (1.57 in. dia.)
M	10 mm (0.39 in.)
N	33 mm (1.30 in.)
O	20 mm dia. (0.79 in. dia.)
P	40 mm dia. (1.57 in. dia.)
Q	63.10 to 63.15 mm dia. (2.484 to 2.486 in. dia.)
R	64 mm dia. (2.52 in. dia.)
S	75 mm dia. (2.95 in. dia.)
C0.3	Chamfer 0.3 mm (0.01 in.)
C1	Chamfer 1 mm (0.04 in.)
C5	Chamfer 5 mm (0.2 in.)

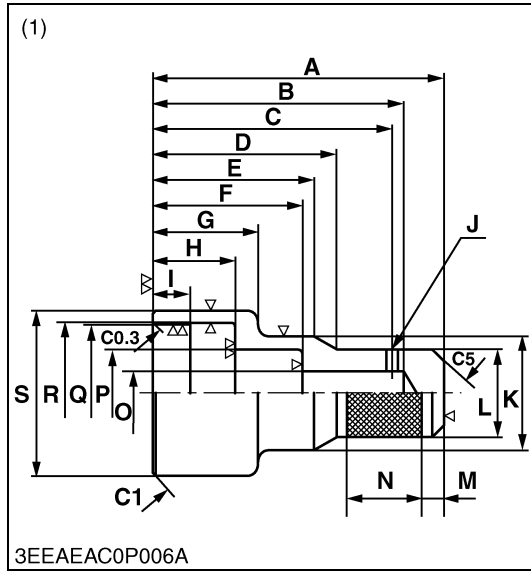

(2) Sleeve Guide

A	42 mm (1.65 in.)
B	12 mm (0.47 in.)
C	30 mm (1.18 in.)
D	M10 × Pitch 1.25
E	2 mm (0.08 in.)
F	10 mm (0.39 in.)
G	2.0 mm (0.08 in.)
H	17.90 to 17.95 mm dia. (0.700 to 0.707 in. dia.)
I	8 mm dia. (0.31 in. dia.)
J	1.8 mm (0.07 in.)
K	0.09 rad (5°)
C0.5	Chamfer 0.5 mm (0.02 in.)

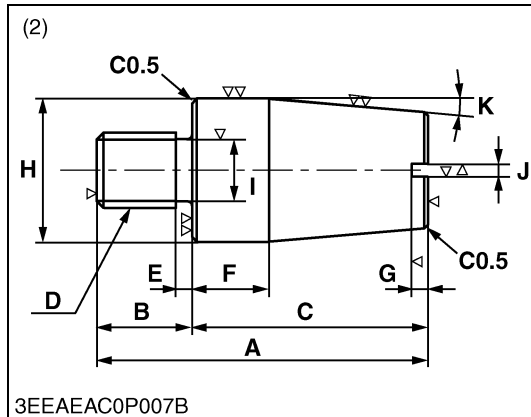

W1026961

MECHANISM

CONTENTS

1. ENGINE BODY	M-1
[1] HALF-FLOATING HEAD COVER	M-1
[2] CLOSED BREATHER	M-1
[3] PISTON (Z602-E2B, D902-E2B)	M-2
[4] OIL PAN (Z602-E2B, D902-E2B)	M-2
2. COOLING SYSTEM	M-2
[1] COOLING FIN (Z602-E2B, D902-E2B)	M-3

1. ENGINE BODY

[1] HALF-FLOATING HEAD COVER

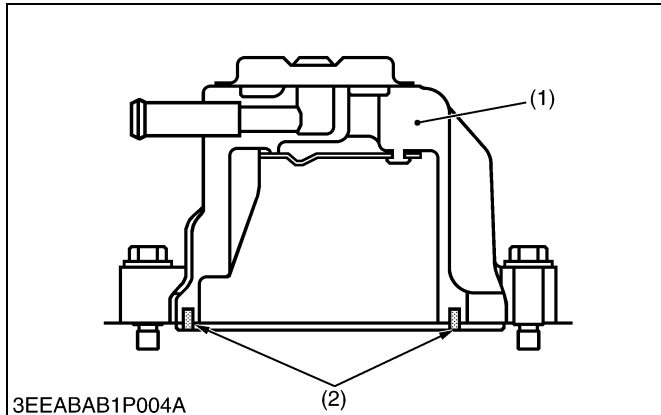

The rubber packing is fitted in to maintain the cylinder head cover 0.5 mm (0.02 in.) or so off the cylinder head. This arrangement helps reduce noise coming from the cylinder head.

- (1) Cylinder Head Cover (2) Rubber Packing

W1013327

[2] CLOSED BREATHER

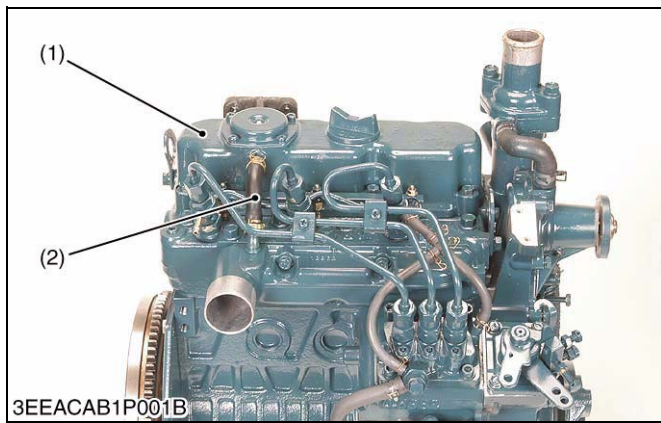

Closed breather system has been adopted to prevent the release of blow-by gas into the atmosphere.

After its oil content is filtered by oil shield (4), the blow-by gas is fed back to the intake manifold through breather valve (3) to be used for re-combustion.

- (1) Cylinder Head Cover (4) Oil Shield
(2) Breather Hose (5) Rubber Packing
(3) Breather Valve

W1012956

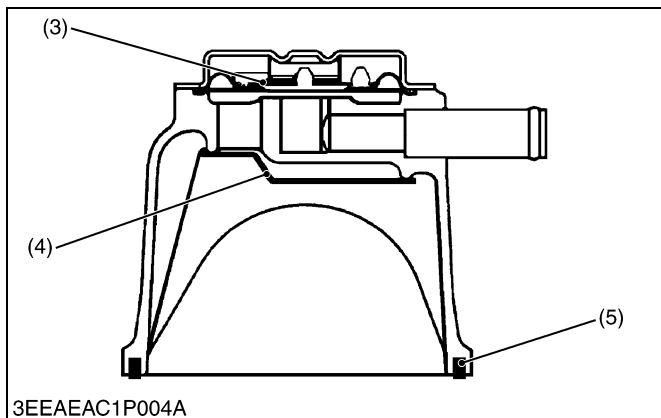

[3] PISTON (Z602-E2B, D902-E2B)

Piston's skirt is coated with **molybdenum disulfide★**, which reduces the piston slap noise and thus the entire operating noise.

★Molybdenum disulfide (MoS₂)

The molybdenum disulfide (1) serves as a solid lubricant, like a Graphite or Teflon. This material helps resist metal wears even with little lube oil.

(1) Molybdenum Disulfide

W1013114

[4] OIL PAN (Z602-E2B, D902-E2B)

The oil pan is extended under the gear case. Therefore, the height of the engine can be lowered more than so far while securing a necessary amount of oil.

(1) Cylinder Block

(3) Oil Pan

(2) Gear Case

W1013041

2. COOLING SYSTEM

[1] COOLING FIN (Z602-E2B, D902-E2B)

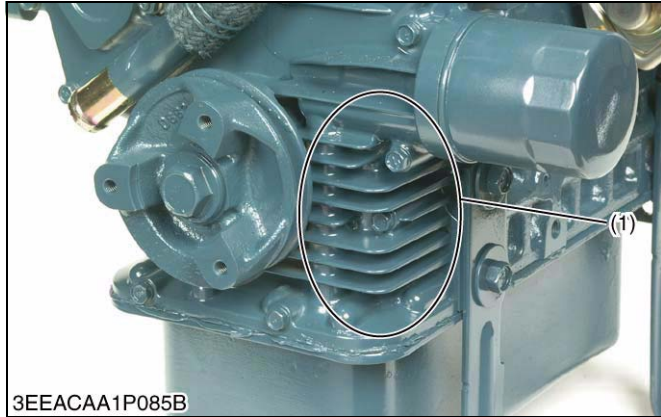

The cooling fin is set up around the oil passage in the gear case.

Therefore, the temperature of oil is decreased by the wind generated by the cooling fan.

(1) Cooling Fin

W1013135

SERVICING

CONTENTS

1. TROUBLESHOOTING	S-1
2. SERVICING SPECIFICATIONS	S-4
3. TIGHTENING TORQUES	S-11
[1] TIGHTENING TORQUES FOR GENERAL USE SCREWS, BOLTS AND NUTS.....	S-11
[2] TIGHTENING TORQUES FOR SPECIAL USE SCREWS, BOLTS AND NUTS.....	S-12
4. CHECKING, DISASSEMBLING AND SERVICING.....	S-13
[1] CHECKING AND ADJUSTING	S-13
(1) Engine Body.....	S-13
(2) Lubricating System	S-15
(3) Cooling System.....	S-15
(4) Fuel System	S-17
(5) Electrical System	S-21
[2] DISASSEMBLING AND ASSEMBLING.....	S-28
(1) Draining Engine Oil and Coolant.....	S-28
(2) External Components	S-29
(3) Cylinder Head, Valves and Oil Pan.....	S-29
(4) Gear Case and Timing Gears	S-35
(5) Piston and Connecting Rod	S-42
(6) Flywheel and Crankshaft	S-45
(7) Starter	S-49
(8) Dynamo.....	S-51
(9) Alternator	S-52
[3] SERVICING	S-53
(1) Cylinder Head and Valves	S-53
(2) Timing Gears	S-59
(3) Piston and Connecting Rod	S-61
(4) Crankshaft.....	S-64
(5) Cylinder.....	S-70
(6) Oil Pump	S-71
(7) Starter	S-72
(8) Alternator	S-75

1. TROUBLESHOOTING

Symptom	Probable Cause	Solution	Reference Page
Engine Does Not Start	No fuel	Replenish fuel	G-10
	Air in the fuel system	Bleed	G-10
	Water in the fuel system	Change fuel and repair or replace fuel system	–
	Fuel hose clogged	Clean or replace	G-10
	Fuel filter clogged	Replace	G-16
	Excessively high viscosity of fuel or engine oil at low temperature	Use specified fuel or engine oil	4, G-8
	Fuel with low cetane number	Use specified fuel	4
	Fuel leak due to loose injection pipe retaining nut	Tighten retaining nut	S-29
	Incorrect injection timing	Adjust	S-17, 18
	Fuel camshaft worn	Replace	S-41
	Injection nozzle clogged	Clean or replace	S-20, 21
	Injection pump malfunctioning	Repair or replace	S-19, 35, 36, 37
	Seizure of crankshaft, camshaft, piston, cylinder or bearing	Repair or replace	S-40 to 48 S-64 to 71
	Compression leak from cylinder	Replace head gasket, tighten cylinder head screw, glow plug and nozzle holder	S-30, 31, 32
	Improper valve timing	Correct or replace timing gear	S-40
	Piston ring and cylinder worn	Replace	S-43, 44, 63
	Excessive valve clearance	Adjust	S-14
Stop solenoid malfunctioning	Replace	S-26, 27, 29, 36	
Starter Does Not Run	Battery discharged	Charge	G-19
	Starter malfunctioning	Repair or replace	S-29, 72 to 75
	Wiring disconnected	Connect	–
Engine Revolution Is Not Smooth	Fuel filter clogged or dirty	Replace	G-16
	Air cleaner clogged	Clean or replace	G-13, 16, 21
	Fuel leak due to loose injection pipe retaining nut	Tighten retaining nut	S-29
	Injection pump malfunctioning	Repair or replace	S-19, 35, 36, 37
	Incorrect nozzle injection pressure	Adjust	S-20
	Injection nozzle stuck or clogged	Repair or replace	S-20, 21
	Governor malfunctioning	Repair	S-41

W1014322

Symptom	Probable Cause	Solution	Reference Page
Either White or Blue Exhaust Gas Is Observed	Excessive engine oil	Reduce to specified level	G-6
	Piston ring and cylinder worn or stuck	Repair or replace	S-43, 44, 63
	Incorrect injection timing	Adjust	S-17, 18
Either Black or Dark Gray Exhaust Gas Is Observed	Overload	Reduce the load	–
	Low grade fuel used	Use specified fuel	4
	Fuel filter clogged	Replace	G-16
	Air cleaner clogged	Clean or replace	G-13, 16, 21
	Deficient nozzle injection	Repair or replace nozzle	S-20, 21
Deficient Output	Incorrect injection timing	Adjust	S-17, 18
	Engine's moving parts seem to be seizing	Repair or replace	–
	Injection pump malfunctioning	Repair or replace	S-19, 35, 36, 37
	Deficient nozzle injection	Repair or replace nozzle	S-20, 21
	Compression leak	Check the compression pressure and repair	S-13
Excessive Lubricant Oil Consumption	Piston ring's gap facing the same direction	Shift ring gap direction	S-43
	Oil ring worn or stuck	Replace	S-43, 44
	Piston ring groove worn	Replace piston	S-43, 44, 63
	Valve stem and valve guide worn	Replace	S-33, 54, 55
	Crankshaft bearing and crank pin bearing worn	Replace	S-47, 48, 65 to 69
	Oil leaking due to defective seals or packing	Replace	–
Fuel Mixed into Lubricant Oil	Injection pump's plunger worn	Repair or replace	S-19, 35, 36, 37
	Deficient nozzle injection	Repair or replace nozzle	S-20, 21
	Injection pump broken	Replace	S-35, 36, 37
Water Mixed into Lubricant Oil	Head gasket defective	Replace	S-32
	Cylinder block or cylinder head flawed	Replace	S-32, 54

W1014322

Symptom	Probable Cause	Solution	Reference Page
Low Oil Pressure	Engine oil insufficient	Replenish	G-6
	Oil strainer clogged	Clean	S-34
	Relief valve stuck with dirt	Clean	–
	Relief valve spring weaken or broken	Replace	–
	Excessive oil clearance of crankshaft bearing	Replace	S-47, 48, 66 to 69
	Excessive oil clearance of crankpin bearing	Replace	S-42, 65
	Excessive oil clearance of rocker arm	Replace	S-31, 57
	Oil passage clogged	Clean	–
	Different type of oil	Use specified type of oil	G-8
	Oil pump defective	Replace	S-41, 71, 72
High Oil Pressure	Different type of oil	Use specified type of oil	G-8
	Relief valve defective	Replace	–
Engine Overheated	Engine oil insufficient	Replenish	G-6
	Fan belt broken or elongated	Replace or adjust	G-13
	Coolant insufficient	Replenish	G-17, 18
	Radiator net and radiator fin clogged with dust	Clean	–
	Inside of radiator corroded	Clean or replace	G-17
	Coolant flow route corroded	Clean or replace	G-17, 18
	Radiator cap defective	Replace	–
	Overload running	Reduce the load	–
	Head gasket defective	Replace	S-32
	Incorrect injection timing	Adjust	S-17, 18
	Unsuitable fuel used	Use specified fuel	4
Battery Quickly Discharged	Battery electrolyte insufficient	Replenish distilled water and charge	G-14
	Fan belt slips	Adjust belt tension or replace	G-13
	Wiring disconnected	Connect	–
	Rectifier defective	Replace	S-52, 76
	Alternator defective	Replace	S-29, 52
	Battery defective	Replace	G-28

W1014322

2. SERVICING SPECIFICATIONS

ENGINE BODY

Item		Factory Specification	Allowable Limit
Valve Clearance (Cold)		0.145 to 0.185 mm 0.00571 to 0.00728 in.	–
Compression Pressure	Z482-E2B D662-E2B D722-E2B D782-E2B	2.84 to 3.24 MPa 29.0 to 33.0 kgf/cm ² 412 to 469 psi	2.26 MPa 23.0 kgf/cm ² 327 psi
	Z602-E2B D902-E2B	3.53 to 4.02 MPa 36.0 to 41.0 kgf/cm ² 512 to 583 psi	2.55 MPa 26.0 kgf/cm ² 370 psi
Difference among Cylinders		–	10 % or less
Top Clearance		0.50 to 0.70 mm 0.0197 to 0.0276 in.	–
Cylinder Head Surface	Flatness	–	0.05 mm 0.0020 in.
Valve Recessing	Intake and Exhaust	–0.10 to 0.10 mm –0.0039 to 0.0039 in.	0.30 mm 0.0118 in.
Valve Stem to Valve Guide	Clearance	0.030 to 0.057 mm 0.00118 to 0.00224 in.	0.10 mm 0.0039 in.
Valve Stem	O.D.	5.968 to 5.980 mm 0.23496 to 0.23543 in.	–
Valve Guide	I.D.	6.010 to 6.025 mm 0.23661 to 0.23720 in.	–
Valve Face	Angle	0.785 rad 45 °	–
Valve Seat	Angle	0.785 rad 45 °	–
	Width	2.12 mm 0.0835 in.	–
Valve Spring	Free Length	31.3 to 31.8 mm 1.232 to 1.252 in.	28.4 mm 1.118 in.
	Tilt	–	1.2 mm 0.047 in.
	Setting Load / Setting Length	64.7 N / 27.0 mm 6.6 kgf / 27.0 mm 14.6 lbs / 1.063 in.	54.9 N / 27.0 mm 5.6 kgf / 27.0 mm 12.3 lbs / 1.063 in.

W10138740

ENGINE BODY (Continued)

Item		Factory Specification	Allowable Limit
Rocker Arm Shaft to Rocker Arm	Oil Clearance	0.016 to 0.045 mm 0.00063 to 0.00177 in.	0.15 mm 0.0059 in.
Rocker Arm Shaft	O.D.	10.473 to 10.484 mm 0.41232 to 0.41276 in.	–
Rocker Arm	I.D.	10.500 to 10.518 mm 0.41339 to 0.41410 in.	–
Push Rod	Alignment	–	0.25 mm 0.0098 in.
Tappet to Tappet Guide	Oil Clearance	0.016 to 0.052 mm 0.00063 to 0.00205 in.	0.10 mm 0.0039 in.
Tappet	O.D.	17.966 to 17.984 mm 0.70732 to 0.70803 in.	–
Tappet Guide	I.D.	18.000 to 18.018 mm 0.70866 to 0.70937 in.	–
Timing Gear			
Crank Gear to Idle Gear	Backlash	0.043 to 0.124 mm 0.00169 to 0.00488 in.	0.15 mm 0.0059 in.
Idle Gear to Cam Gear	Backlash	0.047 to 0.123 mm 0.00185 to 0.00484 in.	0.15 mm 0.0059 in.
Idle Gear to Injection Pump Gear	Backlash	0.046 to 0.124 mm 0.00181 to 0.00488 in.	0.15 mm 0.0059 in.
Crank Gear to Oil Pump Drive Gear	Backlash	0.041 to 0.123 mm 0.00161 to 0.00484 in.	0.15 mm 0.0059 in.
Idle Gear	Side Clearance	0.20 to 0.51 mm 0.0079 to 0.0201 in.	0.80 mm 0.0315 in.
Camshaft	Side Clearance	0.15 to 0.31 mm 0.0059 to 0.0122 in.	0.50 mm 0.0197 in.
	Alignment	–	0.01 mm 0.0004 in.
Cam Height	Intake and Exhaust	26.88 mm 1.0583 in.	26.83 mm 1.0563 in.
Camshaft Journal to Cylinder Block Bore	Oil Clearance	0.050 to 0.091 mm 0.00197 to 0.00358 in.	0.15 mm 0.0059 in.
Camshaft Journal	O.D.	32.934 to 32.950 mm 1.29661 to 1.29724 in.	–
Cylinder Block Bore	I.D.	33.000 to 33.025 mm 1.29921 to 1.30020 in.	–

W1013874

ENGINE BODY (Continued)

Item		Factory Specification	Allowable Limit
Idle Gear Shaft to Idle Gear Bushing	Oil Clearance	0.020 to 0.084 mm 0.00079 to 0.00331 in.	0.10 mm 0.0039 in.
Idle Gear Shaft	O.D.	19.967 to 19.980 mm 0.78610 to 0.78661 in.	–
Idle Gear Bushing	I.D.	20.000 to 20.051 mm 0.78740 to 0.78941 in.	–
Piston Pin Bore	I.D.	20.000 to 20.013 mm 0.78740 to 0.78791 in.	20.05 mm 0.7894 in.
Piston Pin to Small End Bushing	Oil Clearance	0.014 to 0.038 mm 0.00055 to 0.00150 in.	0.10 mm 0.0039 in.
Piston Pin	O.D.	20.002 to 20.011 mm 0.78748 to 0.78783 in.	–
Small End Bushing	I.D.	20.025 to 20.040 mm 0.78839 to 0.78897 in.	–
Piston Pin to Small End Bushing (Spare Parts)	Oil Clearance	0.015 to 0.075 mm 0.00059 to 0.00295 in.	0.15 mm 0.0059 in.
Small End Bushing	I.D.	20.026 to 20.077 mm 0.78843 to 0.79043 in.	–
Piston Ring Gap [Z482-E2B] [D662-E2B] [D722-E2B] [D782-E2B]	Top Ring	0.15 to 0.30 mm 0.0059 to 0.0118 in.	1.20 mm 0.0472 in.
	Second Ring	0.30 to 0.45 mm 0.0118 to 0.0177 in.	1.20 mm 0.0472 in.
	Oil Ring	0.15 to 0.30 mm 0.0059 to 0.0118 in.	1.20 mm 0.0472 in.
Piston Ring Gap [Z602-E2B] [D902-E2B]	Top Ring	0.20 to 0.35 mm 0.0079 to 0.0138 in.	1.25 mm 0.0492 in.
	Second Ring	0.35 to 0.50 mm 0.0138 to 0.0197 in.	1.25 mm 0.0492 in.
	Oil Ring	0.20 to 0.35 mm 0.0079 to 0.0138 in.	1.25 mm 0.0492 in.
Piston Ring to Piston Ring Groove Second Ring	Clearance	0.090 to 0.120 mm 0.00354 to 0.00472 in.	0.15 mm 0.0059 in.
Oil Ring	Clearance	0.04 to 0.08 mm 0.0016 to 0.0031 in.	0.15 mm 0.0059 in.
Connecting Rod	Alignment	–	0.05 mm 0.0020 in.
Crankshaft	Side Clearance	0.15 to 0.31 mm 0.0059 to 0.0122 in.	0.50 mm 0.0197 in.
	Alignment	–	0.02 mm 0.0008 in.

W10138740

ENGINE BODY (Continued)

Item		Factory Specification	Allowable Limit	
Crankpin to Crankpin Bearing	Oil Clearance	0.020 to 0.051 mm 0.00079 to 0.00201 in.	0.15 mm 0.0059 in.	
	Crankpin	O.D.	33.959 to 33.975 mm 1.33697 to 1.33760 in.	–
	Crankpin Bearing	I.D.	33.995 to 34.010 mm 1.33839 to 1.33898 in.	–
Crankshaft Journal to Crankshaft Bearing 1 [Z482/D662/D722/D782-E2B]	Oil Clearance	0.034 to 0.106 mm 0.00134 to 0.00417 in.	0.20 mm 0.0079 in.	
	Crankshaft Journal	O.D.	39.934 to 39.950 mm 1.57221 to 1.57284 in.	–
	Crankshaft Bearing 1	I.D.	39.984 to 40.040 mm 1.57417 to 1.57638 in.	–
Crankshaft Journal to Crankshaft Bearing 1 [Z602/D902-E2B]	Oil Clearance	0.034 to 0.106 mm 0.00134 to 0.00417 in.	0.20 mm 0.0079 in.	
	Crankshaft Journal	O.D.	43.934 to 43.950 mm 1.72968 to 1.73031 in.	–
	Crankshaft Bearing 1	I.D.	43.984 to 44.040 mm 1.73165 to 1.73386 in.	–
Crankshaft Journal to Crankshaft Bearing 2 (Flywheel Side)	Oil Clearance	0.028 to 0.059 mm 0.00110 to 0.00232 in.	0.20 mm 0.0079 in.	
	Crankshaft Journal	O.D.	43.934 to 43.950 mm 1.72968 to 1.73031 in.	–
	Crankshaft Bearing 2	I.D.	43.978 to 43.993 mm 1.73142 to 1.73201 in.	–
Crankshaft Journal to Crankshaft Bearing 3 (Intermediate) [Z482/D662/D722/D782-E2B]	Oil Clearance	0.028 to 0.059 mm 0.00110 to 0.00232 in.	0.20 mm 0.0079 in.	
	Crankshaft Journal	O.D.	39.934 to 39.950 mm 1.57221 to 1.57284 in.	–
	Crankshaft Bearing 3	I.D.	39.978 to 39.993 mm 1.57394 to 1.57453 in.	–
Crankshaft Journal to Crankshaft Bearing 3 (Intermediate) [Z602/D902-E2B]	Oil Clearance	0.028 to 0.059 mm 0.00110 to 0.00232 in.	0.20 mm 0.0079 in.	
	Crankshaft Journal	O.D.	43.934 to 43.950 mm 1.72968 to 1.73031 in.	–
	Crankshaft Bearing 3	I.D.	43.978 to 43.993 mm 1.73142 to 1.73201 in.	–

W10138740

ENGINE BODY (Continued)

Item		Factory Specification	Allowable Limit
Cylinder Liner [D662-E2B]	I.D.	64.000 to 64.019 mm 2.51968 to 2.52043 in.	64.150 mm 2.52559 in.
Cylinder Liner [Z482/D722/D782-E2B]	I.D.	67.000 to 67.019 mm 2.63779 to 2.63854 in.	67.150 mm 2.64370 in.
Cylinder Liner [Z602/D902-E2B]	I.D.	72.000 to 72.019 mm 2.83464 to 2.83539 in.	72.150 mm 2.84055 in.
Cylinder Liner [Oversize : 0.25 mm (0.0098 in.)] [D662-E2B]	I.D.	64.250 to 64.269 mm 2.52953 to 2.53027 in.	64.400 mm 2.53543 in.
Cylinder Liner [Oversize : 0.25 mm (0.0098 in.)] [Z482/D722/D782-E2B]	I.D.	67.250 to 67.269 mm 2.64764 to 2.64839 in.	67.400 mm 2.65354 in.
Cylinder Liner [Oversize : 0.25 mm (0.0098 in.)] [Z602/D902-E2B]	I.D.	72.250 to 72.269 mm 2.84449 to 2.84524 in.	72.400 mm 2.85040 in.

W10138740

LUBRICATING SYSTEM

Engine Oil Pressure	At Idle Speed	More than 49 kPa 0.5 kgf/cm ² 7 psi	–
	At Rated Speed	196 to 441 kPa 2.0 to 4.5 kgf/cm ² 28 to 64 psi	147 kPa 1.5 kgf/cm ² 21 psi
Inner Rotor to Outer Rotor	Clearance	0.03 to 0.14 mm 0.0012 to 0.0055 in.	–
Outer Rotor to Pump Body	Clearance	0.07 to 0.15 mm 0.0028 to 0.0059 in.	–
Inner Rotor to Cover	Clearance	0.075 to 0.135 mm 0.00295 to 0.00531 in.	–

W10139730

COOLING SYSTEM

Item		Factory Specification	Allowable Limit
Fan Belt	Tension	7.0 to 9.0 mm / 98 N 0.28 to 0.35 in. / 98 N (10 kgf, 22 lbs)	–
Thermostat	Valve Opening Temperature (At Beginning)	69.5 to 72.5 °C 157.1 to 162.5 °F	–
	Valve Opening Temperature (Opened Completely)	85 °C 185 °F	–
Radiator Cap	Pressure Falling Time	10 seconds or more 88 → 59 kPa 0.9 → 0.6 kgf/cm ² 13 → 9 psi	–
Radiator	Water Leakage Test Pressure	No leak at specified pressure 157 kPa 1.6 kgf/cm ² 23 psi	–

W10135990

FUEL SYSTEM

Item		Factory Specification	Allowable Limit
Injection Pump [Z482/D662/D722-E2B]	Injection Timing (3600 min ⁻¹ (rpm))	0.33 to 0.37 rad (19 to 21°) before T.D.C.	–
Injection Pump [D782-E2B]	Injection Timing (3200 min ⁻¹ (rpm))	0.28 to 0.31 rad (16 to 18°) before T.D.C.	–
Injection Pump [Z602/D902-E2B]	Injection Timing (3200 min ⁻¹ (rpm))	0.30 to 0.33 rad (17 to 19°) before T.D.C.	–
Injection Pump [Z602/D902-E2B]	Injection Timing (3600 min ⁻¹ (rpm))	0.33 to 0.37 rad (19 to 21°) before T.D.C.	–
Pump Element	Fuel Tightness	–	13.73 MPa 140 kgf/cm ² 1991 psi
Delivery Valve	Fuel Tightness	10 seconds 13.73 → 12.75 MPa 140 → 130 kgf/cm ² 1991 → 1849 psi	5 seconds 13.73 → 12.75 MPa 140 → 130 kgf/cm ² 1991 → 1849 psi
Injection Nozzle	Injection Pressure	13.73 to 14.71 MPa 140 to 150 kgf/cm ² 1991 to 2134 psi	–
Injection Nozzle Valve Seat	Valve Seat Tightness	When the pressure is 12.75 MPa (130 kgf/cm ² , 1849 psi), the valve seat must be fuel tightness.	–

W10139730

ELECTRICAL SYSTEM

Item		Factory Specification	Allowable Limit
Glow Plug	Resistance	Approx. 0.9 Ω	–
Starter (Electromagnetic Drive Type) Commutator	O.D.	28.0 mm 1.102 in.	27.0 mm 1.063 in.
	Difference	Less than 0.05 mm 0.0002 in.	0.4 mm 0.016 in.
	Mica	Undercut 0.50 to 0.80 mm 0.0197 to 0.0315 in.	0.20 mm 0.0079 in.
	Brush	Length 16.0 mm 0.630 in.	10.5 mm 0.413 in.
Starter (Planetary Gear Reduction Type) Commutator	O.D.	30.0 mm 1.181 in.	29.0 mm 1.142 in.
	Difference	Less than 0.02 mm 0.0008 in.	0.05 mm 0.0020 in.
	Mica	Undercut 0.50 to 0.80 mm 0.0197 to 0.0315 in.	0.20 mm 0.0079 in.
	Brush	Length 14.0 mm 0.551 in.	9.0 mm 0.354 in.
Dynamo	No-load Output Voltage	AC20V or more at 5200 min ⁻¹ (rpm)	–
	Regulating Output Voltage	14 to 15 V at 5200 min ⁻¹ (rpm)	–
Alternator	Stator Resistance	Less than 1.0 Ω	–
	Rotor Resistance	2.9 Ω	–
	Slip Ring O.D.	14.4 mm 0.567 in.	14.0 mm 0.551 in.
	Brush Length	10.5 mm 0.413 in.	8.4 mm 0.331 in.

W1013973

3. TIGHTENING TORQUES

Screws, bolts and nuts must be tightened to the specified torque using a torque wrench, several screws, bolts and nuts such as those used on the cylinder head must be tightened in proper sequence and the proper torque.

[1] TIGHTENING TORQUES FOR GENERAL USE SCREWS, BOLTS AND NUTS

When the tightening torques are not specified, tighten the screws, bolts and nuts according to the table below.

Grade Nominal Diameter	Unit	Standard Screw and Bolt ④			Special Screw and Bolt ⑦		
		N·m	kgf·m	ft-lbs	N·m	kgf·m	ft-lbs
M6		7.9 to 9.3	0.80 to 0.95	5.8 to 6.9	9.8 to 11.3	1.00 to 1.15	7.23 to 8.32
M8		17.7 to 20.6	1.8 to 2.1	13.0 to 15.2	23.5 to 27.5	2.4 to 2.8	17.4 to 20.3
M10		39.2 to 45.1	4.0 to 4.6	28.9 to 33.3	48.1 to 55.9	4.9 to 5.7	35.4 to 41.2
M12		62.8 to 72.6	6.4 to 7.4	46.3 to 53.5	77.5 to 90.2	7.9 to 9.2	57.1 to 66.5

W10371750

Screw and bolt material grades are shown by numbers punched on the screw and bolt heads. Prior to tightening, be sure to check out the numbers as shown below.

Punched number	Screw and bolt material grade
None or 4	Standard screw and bolt SS41, S20C
7	Special screw and bolt S43C, S48C (Refined)

W1012705

[2] TIGHTENING TORQUES FOR SPECIAL USE SCREWS, BOLTS AND NUTS

■ NOTE

- For “*” marked screws, bolts and nuts on the table, apply engine oil to their threads and seats before tightening.
- The letter “M” in Size x Pitch means that the screw, bolt or nut dimension stands for metric. The size is the nominal outside diameter in mm of the threads. The pitch is the nominal distance in mm between two threads.

Item	Size x Pitch	N·m	kgf·m	ft-lbs
*Cylinder head cover screw	M6 x 1	9.8 to 11.3	1.00 to 1.15	7.2 to 8.3
Injection pipe retaining nut	M12 x 1.5	24.5 to 34.3	2.5 to 3.5	18.1 to 25.3
Overflow pipe retaining nut	M12 x 1.5	19.6 to 24.5	2.0 to 2.5	14.5 to 18.1
Nozzle holder assembly	M20 x 1.5	49.0 to 68.6	5.0 to 7.0	36.2 to 50.6
Glow plug	M8 x 1	7.8 to 14.7	0.8 to 1.5	5.8 to 10.8
*Rocker arm bracket nut	M6 x 1	9.8 to 11.3	1.00 to 1.15	7.2 to 8.3
*Cylinder head screw	M8 x 1.25	37.3 to 42.2	3.8 to 4.3	27.5 to 31.1
*Fan drive pulley screw	M12 x 1.5	117.7 to 127.5	12.0 to 13.0	86.8 to 94.0
*Idle gear shaft mounting screw	M6 x 1	9.8 to 11.3	1.00 to 1.15	7.2 to 8.3
Oil pump mounting screw	M8 x 1.25	17.7 to 21.6	1.80 to 2.20	13.0 to 15.9
*Connecting rod screw	M7 x 0.75	26.5 to 30.4	2.7 to 3.1	19.5 to 22.4
*Flywheel screw	M10 x 1.25	53.9 to 58.8	5.5 to 6.0	39.8 to 43.4
Bearing case cover mounting screw	M6 x 1	9.8 to 11.3	1.00 to 1.15	7.2 to 8.3
*Main bearing case screw 2	M7 x 1	26.5 to 30.4	2.7 to 3.1	19.5 to 22.4
*Main bearing case screw 1	M6 x 1	12.7 to 15.7	1.3 to 1.6	9.4 to 11.6
Oil pressure switch	PT 1/8	14.7 to 19.6	1.5 to 2.0	10.8 to 14.5
Nozzle holder	–	34.3 to 39.2	3.5 to 4.0	25.3 to 28.9
Starter's terminal B mounting nut (Electromagnetic drive type)	M8	7.8 to 9.8	0.8 to 1.0	5.8 to 7.2
Starter's terminal B mounting nut (Planetary gear reduction type)	M8	5.9 to 11.8	0.6 to 1.2	4.3 to 8.7
Dynamo's pulley nut	M10 x 1.25	39.2 to 44.1	4.0 to 4.5	28.9 to 32.5
Alternator's pulley nut	–	58.3 to 78.9	5.95 to 8.05	43.0 to 58.2
Drain plug with copper gasket	M12 x 1.25	32.4 to 37.3	3.3 to 3.8	23.9 to 27.5
Drain plug with copper gasket	M22 x 1.5	63.7 to 73.5	6.5 to 7.5	47.0 to 54.2
Drain plug with rubber coated gasket	M22 x 1.5	44.1 to 53.9	4.5 to 5.5	32.5 to 39.8

W1013236

4. CHECKING, DISASSEMBLING AND SERVICING

[1] CHECKING AND ADJUSTING

(1) Engine Body



Compression Pressure

1. Run the engine until it is warmed up.
2. Stop the engine.
3. **[a] Nozzle Hole Adaptor Setting :**
Remove the air cleaner, the muffler and all injection nozzles.
[b] Glow Plug Hole Adaptor Setting :
Remove the air cleaner, the muffler, the breather tube, the head cover and all glow plugs.
4. **[a] Nozzle Hole Adaptor Setting :**
Set a compression tester (Code No. 07909-30208) with the adaptor (Adaptor H, code No. 07909-31231) to the nozzle hole.
[b] Glow Plug Hole Adaptor Setting :
Set a compression tester (Code No. 07909-30208) with the adaptor (Adaptor L, code No. 07909-31301) to the glow plug hole.
5. After making sure that the stop lever is set at the stop position (non-injection), run the engine with the starter and measure the compression pressure.
6. Repeat steps 4 and 5 for each cylinder.
7. If the measurement is below the allowable limit, apply a small amount of oil to the cylinder wall through the glow plug hole (or nozzle hole) and measure the compression pressure again.
8. If the compression pressure is still less than the allowable limit, check the top clearance, valve clearance and cylinder head.
9. If the compression pressure increases after applying oil, check the cylinder wall and piston rings.

■ NOTE

- Check the compression pressure with the specified valve clearance.
- Always use a fully charged battery for performing this test.
- Variances in cylinder compression values should be under 10 %.

Compression pressure	Factory spec.	Z482-E2B D662-E2B D722-E2B D782-E2B	2.84 to 3.24 MPa 29 to 33 kgf/cm ² 412 to 469 psi
		Z602-E2B D902-E2B	3.53 to 4.02 MPa 36 to 41 kgf/cm ² 512 to 583 psi
	Allowable limit	Z482-E2B D662-E2B D722-E2B D782-E2B	2.26 MPa 23 kgf/cm ² 327 psi
		Z602-E2B D902-E2B	2.55 MPa 26 kgf/cm ² 370 psi

[a] Nozzle Hole Adaptor Setting

[b] Glow Plug Hole Adaptor Setting

W10178940

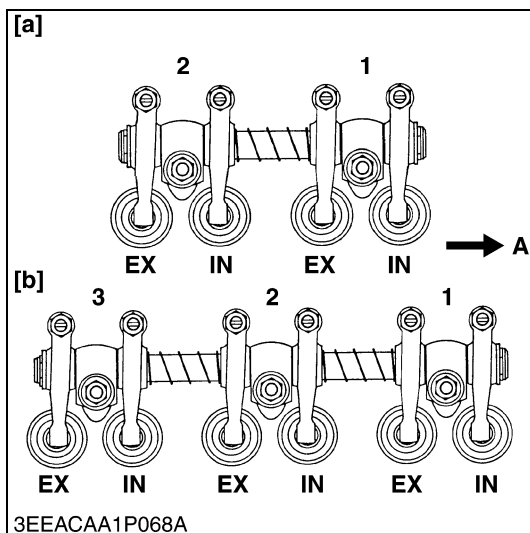
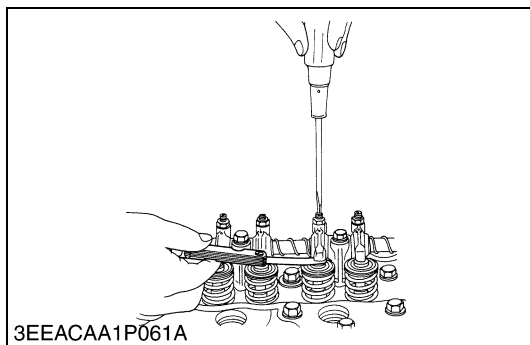
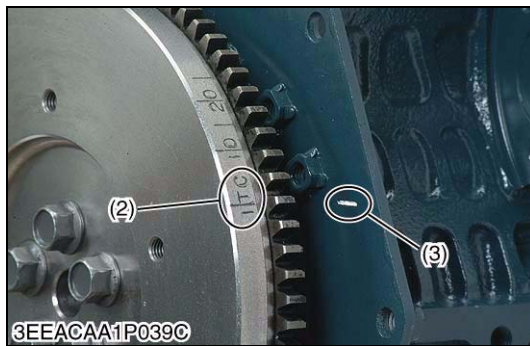
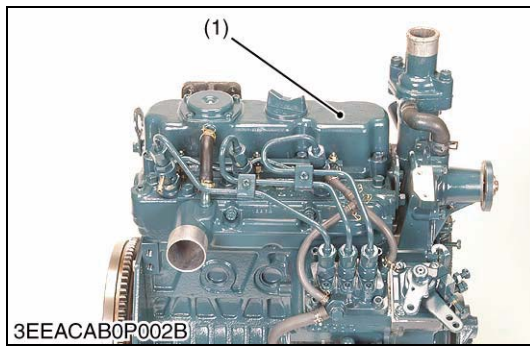

Checking Valve Clearance

■ IMPORTANT

- Valve clearance must be checked and adjusted when engine is cold.

1. Remove the cylinder head cover (1) and the glow plugs.
2. Align the "1TC" mark (2) on the flywheel and alignment mark (3) on the rear end plate so that the No. 1 piston comes to the compression top dead center.
3. Check the following valve clearance marked with "★" using a feeler gauge.
4. If the clearance is not within the factory specifications, adjust with the adjusting screw.
5. Then turn the flywheel 6.28 rad (360 °), and align the "1TC" mark (2) on the flywheel and alignment mark (3) on the rear end plate so that the No. 1 piston comes to the overlap position.
6. Check the following valve clearance marked with "☆" using a feeler gauge.
7. If the clearance is not within the factory specifications, adjust with the adjusting screw.

Number of cylinders Valve arrangement	Z482-E2B Z602-E2B		D662-E2B D722-E2B D782-E2B D902-E2B	
	Intake valve	Exhaust valve	Intake valve	Exhaust valve
Adjustable cylinder location of piston				
No. 1	★	★	★	★
No. 2	☆	★	☆	★
No. 3	—	—	★	☆

★ : When No. 1 piston is at the compression top dead center position.

☆ : When No. 1 piston is at the overlap position.

Intake and exhaust valve clearance (cold)	Factory spec.	0.145 to 0.185 mm 0.00571 to 0.00728 in.
---	---------------	---

■ NOTE

- The sequence of cylinder numbers is given as No. 1, No. 2 and No. 3 starting from the gear case side.
- After adjusting the valve clearance, secure the adjusting screw with the lock nut.

- (1) Cylinder Head Cover
- (2) "1TC" Mark
- (3) Alignment Mark

- A : Gear Case Side
- [a] Z482-E2B, Z602-E2B
- [b] D662-E2B, D722-E2B, D782-E2B, D902-E2B

W10172470

(2) Lubricating System

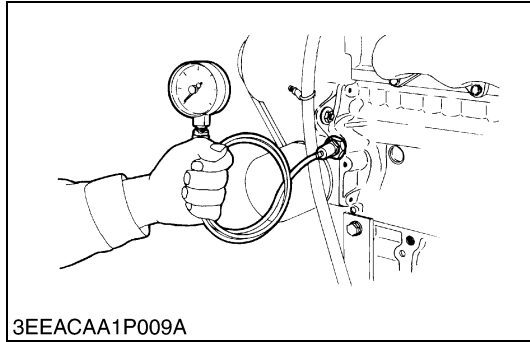

Engine Oil Pressure

1. Remove the engine oil pressure switch, and set an oil pressure tester. (Code No. : 07916-32032.)
2. Start the engine. After warming up, measure the oil pressure of both idling and rated speeds.
3. If the oil pressure is less than the allowable limit, check the following.
 - Engine oil insufficient
 - Oil pump defective
 - Oil strainer clogged
 - Oil filter cartridge clogged
 - Oil gallery clogged
 - Excessive oil clearance
 - Foreign matter in the relief valve

Engine oil pressure	At idle speed	Factory spec.	More than 49 kPa 0.5 kgf/cm ² 7 psi
	At rated speed	Factory spec.	196 to 441 kPa 2.0 to 4.5 kgf/cm ² 28 to 64 psi
		Allowable limit	147 kPa 1.5 kgf/cm ² 21 psi

(When reassembling)

- After checking the engine oil pressure, tighten the engine oil pressure switch to the specified torque.

Tightening torque	Oil pressure switch	14.7 to 19.6 N·m 1.5 to 2.0 kgf·m 10.8 to 14.5 ft-lbs
-------------------	---------------------	---

W10349520

(3) Cooling System

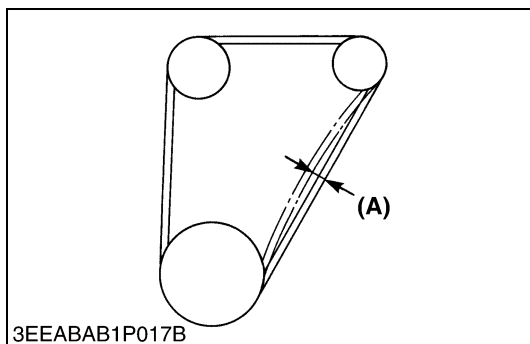

Fan Belt Tension

1. Measure the deflection **(A)**, depressing the belt halfway between the fan drive pulley and alternator pulley at specified force 98 N (10 kgf, 22 lbs).
2. If the measurement is not within the factory specifications, loosen the alternator mounting screws and relocate the alternator to adjust.

Deflection (A)	Factory spec.	7.0 to 9.0 mm 0.28 to 0.35 in.
-----------------------	---------------	-----------------------------------

(A) Deflection

W10356670



Fan Belt Damage and Wear

1. Check the fan belt for damage.
2. If the fan belt is damaged, replace it.
3. Check if the fan belt is worn and sunk in the pulley groove.
4. If the fan belt is nearly worn out and deeply sunk in the pulley groove, replace it.

(A) Good

(B) Bad

W1016443

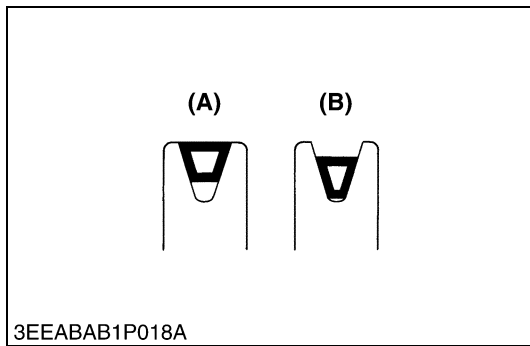

CAUTION

- When removing the radiator cap, wait at least ten minutes after the engine has stopped and cooled down. Otherwise, hot water may gush out, scalding nearby people.

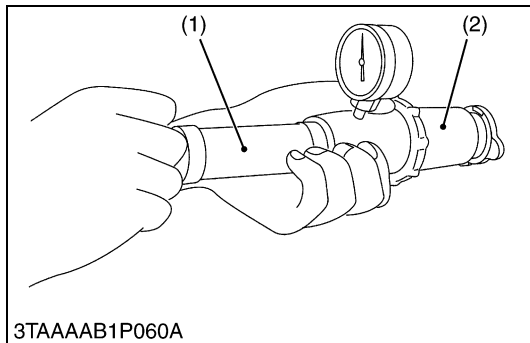

Radiator Cap Air Leakage

1. Set a radiator tester (1) and an adaptor (2) on the radiator cap.
2. Apply the specified pressure (88 kPa, 0.9 kgf/cm², 13 psi), and measure the time for the pressure to fall to 59 kPa (0.6 kgf/cm², 9 psi).
3. If the measurement is less than the factory specification, replace the radiator cap.

Pressure falling time	Factory spec.	More than 10 seconds for pressure fall from 88 to 59 kPa (from 0.9 to 0.6 kgf/cm ² , from 13 to 9 psi)
-----------------------	---------------	---

(1) Radiator Tester

(2) Adaptor

W1054156

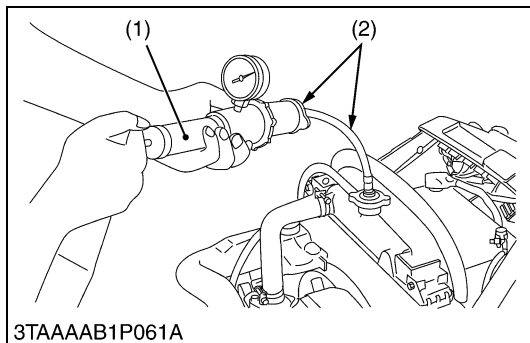

Radiator Water Leakage

1. Pour a specified amount of water into the radiator.
2. Set a radiator tester (1) and an adaptor (2) and raise the water pressure to the specified pressure.
3. Check the radiator for water leaks.
4. For water leak from the pinhole, repair with the radiator cement. When water leak is excessive, replace the radiator.

Radiator water leakage test pressure	Factory spec.	157 kPa 1.6 kgf/cm ² 23 psi
--------------------------------------	---------------	--

(1) Radiator Tester

(2) Adaptor

W1016903

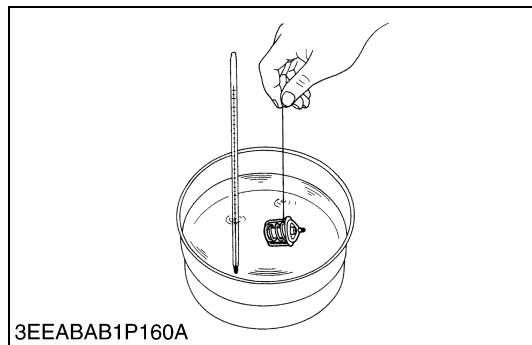

Thermostat Valve Opening Temperature

1. Suspend the thermostat in the water by a string with its end inserted between the valve and seat.
2. Heating the water gradually, read the temperature when the valve opens and leaves the string.
3. Continue heating and read the temperature when the valve opens approx. 8 mm (0.315 in.).
4. If the measurement is not within the factory specifications, replace the thermostat.

Thermostat's valve opening temperature	Factory spec.	69.5 to 72.5 °C 157.1 to 162.5 °F
Temperature at which thermostat completely opens	Factory spec.	85 °C 185 °F

W1035849

(4) Fuel System

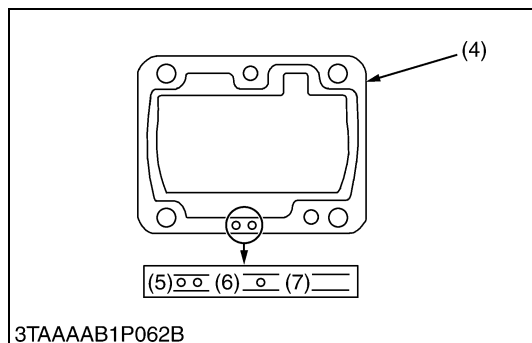
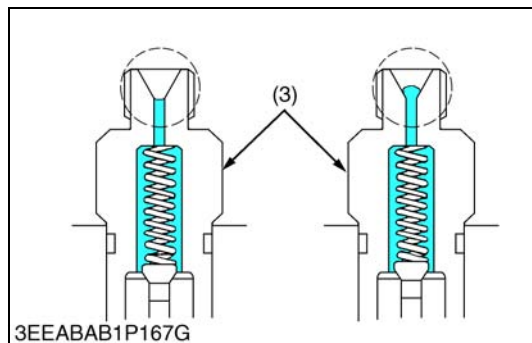
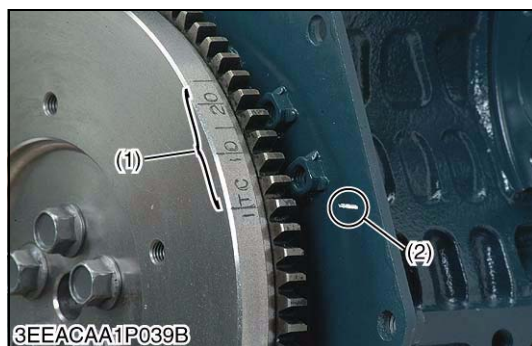

Injection Timing

1. Remove the injection pipes.
2. Remove the engine stop solenoid.
3. Turn the flywheel counterclockwise (viewed from flywheel side) until the fuel fills up to the hole of the delivery valve holder (3) for No. 1 cylinder.
4. After the fuel fills up to the hole of the delivery valve holder for No. 1 cylinder, turn back (clockwise) the flywheel around 1.57 rad (90 °).
5. Turn the flywheel counterclockwise to set at around 0.44 rad (25 °) before T.D.C..
6. Slowly turn the flywheel counterclockwise and stop turning when the fuel begins to come up, to get the present injection timing.
7. Check to see the degree on flywheel.
The flywheel has mark "1TC", "10" and "20" for the crank angle before the top dead center of No. 1 cylinder.
8. Check to see if the timing angle on the flywheel is aligned with the alignment mark (2).
9. If injection timing is out of adjustment, readjust the timing with shims.

Z482/D662/D722-E2B (3600 min⁻¹ (rpm) spec.)

Injection timing	Factory spec.	0.33 to 0.37 rad (19 to 21 °) before T.D.C.
------------------	---------------	---

D782-E2B (3200 min⁻¹ (rpm) spec.)

Injection timing	Factory spec.	0.28 to 0.31 rad (16 to 18 °) before T.D.C.
------------------	---------------	---

Z602/D902-E2B (3200 min⁻¹ (rpm) spec.)

Injection timing	Factory spec.	0.30 to 0.33 rad (17 to 19 °) before T.D.C.
------------------	---------------	---

Z602/D902-E2B (3600 min⁻¹ (rpm) spec.)

Injection timing	Factory spec.	0.33 to 0.37 rad (19 to 21 °) before T.D.C.
------------------	---------------	---

- | | |
|-----------------------------------|---|
| (1) Timing Line | (5) Two-holes : 0.20 mm (0.0079 in.) |
| (2) Alignment Mark | (6) One-hole : 0.25 mm (0.0098 in.) |
| (3) Delivery Valve Holder | (7) Without hole : 0.30 mm (0.0118 in.) |
| (4) Shim (Soft Metal Gasket Shim) | |

W1018724

Injection Timing (Continued)**NOTE**

- The sealant is applied to both sides of the shims (soft metal gasket shim). The liquid gasket is not required for assembling.
- Shims are available in thickness of 0.20 mm (0.0079 in.), 0.25 mm (0.0098 in.) and 0.30 mm (0.0118 in.). Combine these shims for adjustments.
- Addition or reduction of shim (0.05 mm, 0.0020 in.) delays or advances the injection timing by approx. 0.0087 rad (0.5 °).
- In disassembling and replacing the injection pump, be sure to use the same number of new shims with the same thickness.
- Refer to figure of the shim to check the thickness of the shims.
- The injection timing might be changed by the application.

(Reference)

- Injection Timing Map (before T.D.C.)

Rated Speed Specification (min ⁻¹ (rpm))	Model		
	Z482-E2B D662-E2B D722-E2B	D782-E2B	Z602-E2B D902-E2B
3600 to 3301	0.33 to 0.37 rad (19 to 21 °)	–	0.33 to 0.37 rad (19 to 21 °)
3300 to 3001	0.31 to 0.35 rad (18 to 20 °)	0.28 to 0.31 rad (16 to 18 °)	0.30 to 0.33 rad (17 to 19 °)
3000 to 2501	0.30 to 0.33 rad (17 to 19 °)	0.28 to 0.31 rad (16 to 18 °)	0.28 to 0.31 rad (16 to 18 °)
2500 to 2001	0.26 to 0.30 rad (15 to 17 °)	0.24 to 0.28 rad (14 to 16 °)	0.24 to 0.28 rad (14 to 16 °)
Under 2000	0.23 to 0.26 rad (13 to 15 °)	0.23 to 0.26 rad (13 to 15 °)	0.23 to 0.26 rad (13 to 15 °)

W1018986

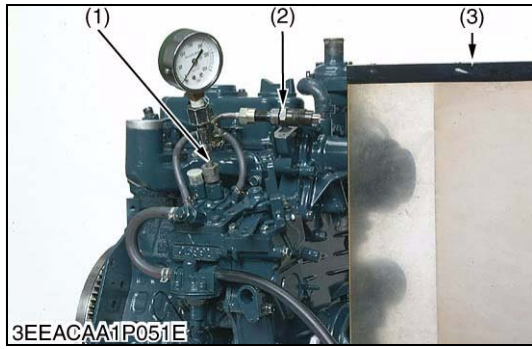

Fuel Tightness of Pump Element

1. Remove the engine stop solenoid.
2. Remove the injection pipes and glow plugs.
3. Install the injection pump pressure tester to the injection pump.
4. Install the injection nozzle (2) jetted with the proper injection pressure to the injection pump pressure tester (1). (Refer to the photo.)
5. Set the speed control lever to the maximum speed position.
6. Run the starter to increase the pressure.
7. If the pressure can not reach the allowable limit, replace the pump with new one or repair with a Kubota-authorized pump service shop.

Fuel tightness of pump element	Allowable limit	13.73 MPa 140 kgf/cm ² 1991 psi
--------------------------------	-----------------	--

NOTE

- **Never try to disassemble the injection pump assembly. For repairs, you are strongly requested to contact a Kubota-authorized pump service shop.**

- (1) Injection Pump Pressure Tester (3) Protection Cover for Jetted Fuel
(2) Injection Nozzle

W1017430

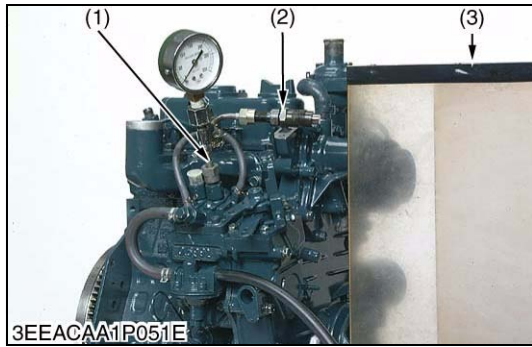

Fuel Tightness of Delivery Valve

1. Remove the engine stop solenoid.
2. Remove the injection pipes and glow plugs.
3. Set a pressure tester to the fuel injection pump.
4. Install the injection nozzle (2) jetted with the proper injection pressure to the injection pump pressure tester (1).
5. Run the starter to increase the pressure.
6. Stop the starter when the fuel jets from the injection nozzle. After that, turn the flywheel by hands and raise the pressure to approx. 13.73 MPa (140 kgf/cm², 1991 psi).
7. Now turn the flywheel back about half a turn (to keep the plunger free). Maintain the flywheel at this position and clock the time taken for the pressure to drop from 13.73 to 12.75 MPa (from 140 to 130 kgf/cm², from 1991 to 1849 psi).
8. Measure the time needed to decrease the pressure from 13.73 to 12.75 MPa (140 to 130 kgf/cm², 1991 to 1849 psi).
9. If the measurement is less than allowable limit, replace the pump with new one or repair with a Kubota-authorized pump service shop.

Fuel tightness of delivery valve	Factory spec.	10 seconds 13.73 → 12.75 MPa 140 → 130 kgf/cm ² 1991 → 1849 psi
	Allowable limit	5 seconds 13.73 → 12.75 MPa 140 → 130 kgf/cm ² 1991 → 1849 psi

NOTE

- **Never try to disassemble the injection pump assembly. For repairs, you are strongly requested to contact a Kubota-authorized pump service shop.**

- (1) Injection Pump Pressure Tester (3) Protection Cover for Jetted Fuel
(2) Injection Nozzle

W1017786

CAUTION

- Check the nozzle injection pressure and condition after confirming that there is nobody standing in the direction the fume goes.
- If the fume from the nozzle directly contacts the human body, cells may be destroyed and blood poisoning may be caused.

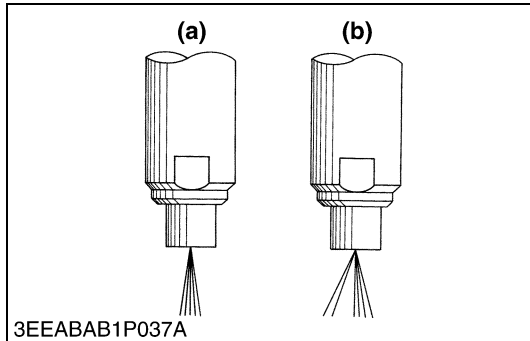

Nozzle Spraying Condition

1. Set the injection nozzle to a nozzle tester, and check the nozzle spraying condition.
2. If the spraying condition is defective, replace the nozzle piece.

(a) Good

(b) Bad

W10181310

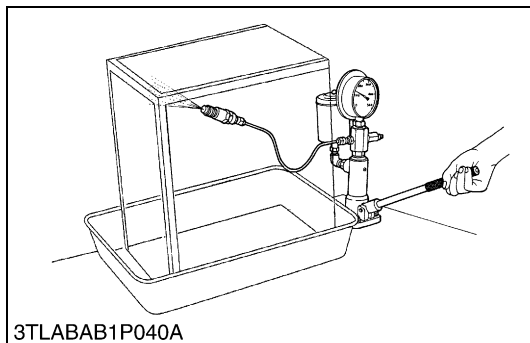

Fuel Injection Pressure

1. Set the injection nozzle to a nozzle tester.
2. Slowly move the tester handle to measure the pressure at which fuel begins jetting out from the nozzle.
3. If the measurement is not within the factory specifications, replace the adjusting washer (1) in the nozzle holder to adjust it.

(Reference)

- Pressure variation with 0.025 mm (0.0010 in.) difference of adjusting washer thickness.
Approx. 588 kPa (6.0 kgf/cm², 85 psi)

Fuel injection pressure	Factory spec.	13.73 to 14.71 MPa 140 to 150 kgf/cm ² 1991 to 2134 psi
-------------------------	---------------	--

(1) Adjusting Washer

W10182100

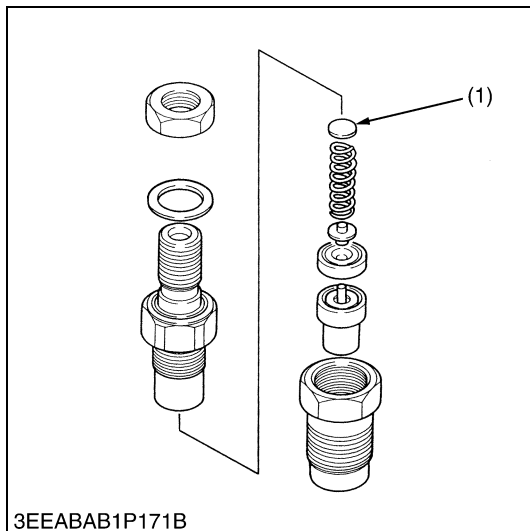

Nozzle Valve Seat Tightness

1. Set the injection nozzle to a nozzle tester.
2. Raise the fuel pressure, and keep at 12.75 MPa (130 kgf/cm², 1849 psi) for 10 seconds.
3. If any fuel leak is found, replace the nozzle piece.

Valve seat tightness	Factory spec.	No fuel leak at 12.75 MPa 130 kgf/cm ² 1849 psi
----------------------	---------------	---

W10183690

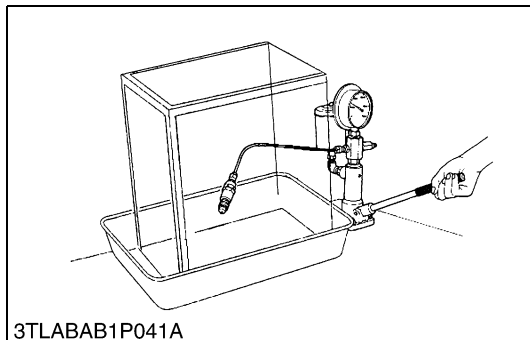

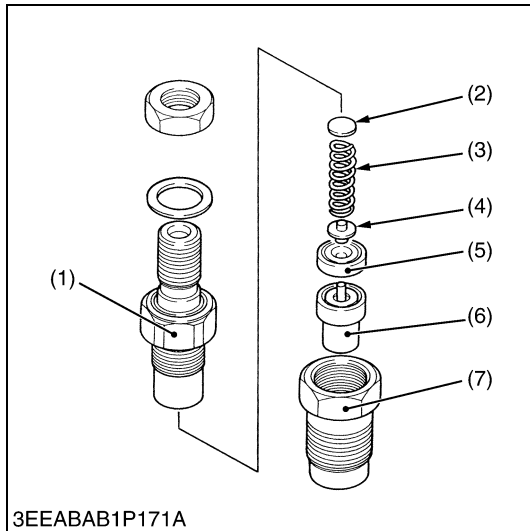

3EEABAB1P171A

Nozzle Holder

1. Secure the nozzle retaining nut (7) with a vise.
2. Remove the nozzle holder (1), and take out parts inside.

(When reassembling)

- Assemble the nozzle in clean fuel oil.
- Install the push rod (4), noting its direction.
- After assembling the nozzle, be sure to adjust the fuel injection pressure.

Tightening torque	Nozzle holder	34.3 to 39.2 N·m 3.5 to 4.0 kgf·m 25.3 to 28.9 ft-lbs
	Overflow pipe retaining nut	19.6 to 24.5 N·m 2.0 to 2.5 kgf·m 14.5 to 18.1 ft-lbs
	Nozzle holder assembly	49.0 to 68.6 N·m 5.0 to 7.0 kgf·m 36.2 to 50.6 ft-lbs

- | | |
|----------------------|--------------------------|
| (1) Nozzle Holder | (5) Distance Piece |
| (2) Adjusting Washer | (6) Nozzle Piece |
| (3) Nozzle Spring | (7) Nozzle Retaining Nut |
| (4) Push Rod | |

W1018491

(5) Electrical System

CAUTION

- To avoid accidental short circuit, be sure to attach the positive cable to the positive terminal before the negative cable is attached to the negative terminal.
- Never remove the battery cap while the engine is running.
- Keep electrolyte away from eyes, hands and clothes. If you are splattered with it, wash it away completely with water immediately.
- Keep open sparks and flames away from the battery at all times. Hydrogen gas mixed with oxygen becomes very explosive.

IMPORTANT

- If the machine is to be operated for a short time without battery (using a slave battery for starting), use additional current (lights) while engine is running and insulate terminal of battery. If this advice is disregarded, damage to alternator and regulator may result.

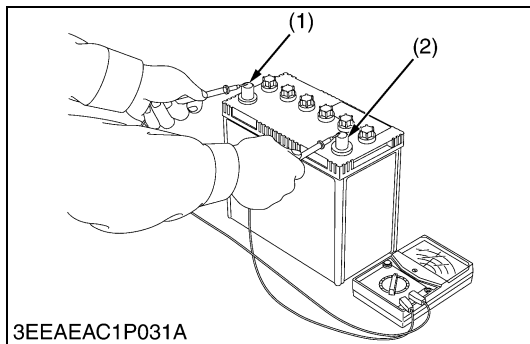

3EEAEAC1P031A

Battery Voltage

1. Stop the engine.
2. Measure the voltage with a circuit tester between the battery terminals.
3. If the battery voltage is less than the factory specification, check the battery specific gravity and recharge the battery.

Battery voltage	Factory spec.	More than 12 V
-----------------	---------------	----------------

- | | |
|-----------------------|-----------------------|
| (1) Positive Terminal | (2) Negative Terminal |
|-----------------------|-----------------------|

W10125620

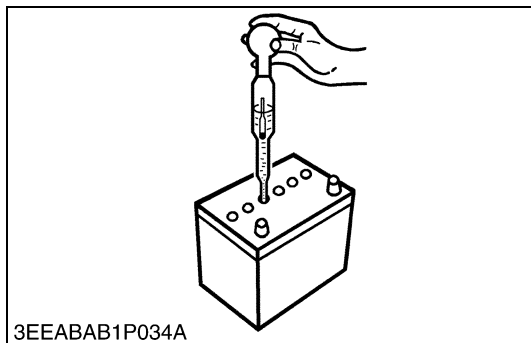

3EEABAB1P034A

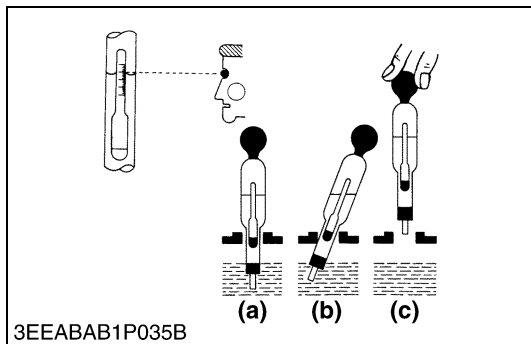

3EEABAB1P035B

Battery Specific Gravity

1. Check the specific gravity of the electrolyte in each cell with a hydrometer.
2. When the electrolyte temperature differs from that at which the hydrometer was calibrated, correct the specific gravity reading following the formula mentioned in **(Reference)**.
3. If the specific gravity is less than 1.215 (after it is corrected for temperature), charge or replace the battery.
4. If the specific gravity differs between any two cells by more than 0.05, replace the battery.

NOTE

- **Hold the hydrometer tube vertical without removing it from the electrolyte.**
- **Do not suck too much electrolyte into the tube.**
- **Allow the float to move freely and hold the hydrometer at eye level.**
- **The hydrometer reading must be taken at the highest electrolyte level.**

(Reference)

- Specific gravity slightly varies with temperature. To be exact, the specific gravity decreases by 0.0007 with an increase of 1 °C (0.0004 with an increase of 1 °F) in temperature, and increases by 0.0007 with a decreases of 1 °C (0.0004 with a decrease of 1 °F).

Therefore, using 20 °C (68 °F) as a reference, the specific gravity reading must be corrected by the following formula :

- Specific gravity at 20 °C = Measured value + 0.0007 × (electrolyte temperature – 20 °C)
- Specific gravity at 68 °F = Measured value + 0.0004 × (electrolyte temperature – 68 °F)

Specific Gravity	State of Charge
1.260 Sp. Gr.	100 % Charged
1.230 Sp. Gr.	75 % Charged
1.200 Sp. Gr.	50 % Charged
1.170 Sp. Gr.	25 % Charged
1.140 Sp. Gr.	Very Little Useful Capacity
1.110 Sp. Gr.	Discharged

At an electrolyte temperature of 20 °C (68 °F)

(a) Good

(b) Bad

(c) Bad

W1019017

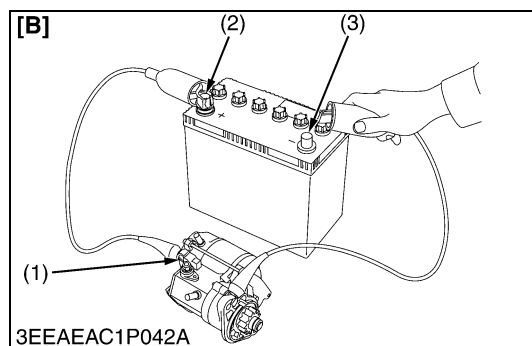
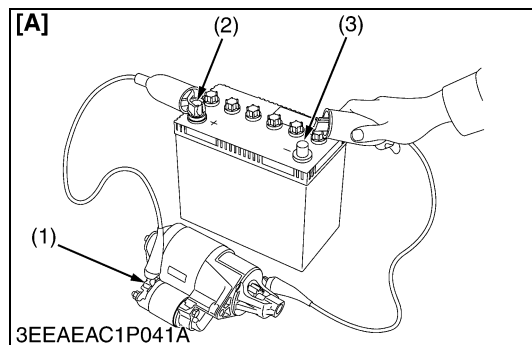
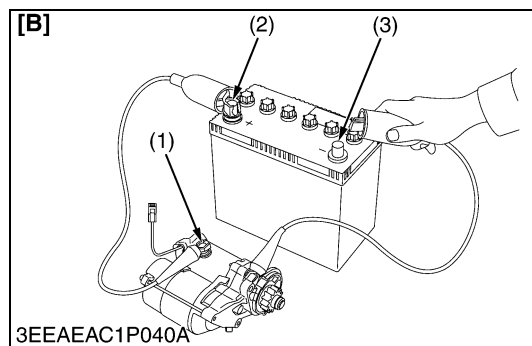
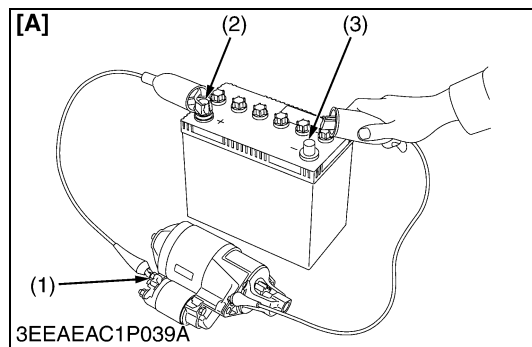

Motor Test

⚠ CAUTION

- **Secure the starter to prevent it from jumping up and down while testing the motor.**
1. Disconnect the battery negative cable from the battery.
 2. Disconnect the battery positive cable from the battery.
 3. Disconnect the leads from the starter **B** terminal.
 4. Remove the starter from the engine.
 5. Connect a jumper lead from the starter **C** terminal (1) to the battery positive terminal (2).
 6. Connect a jumper lead momentarily between the starter's body and the battery negative terminal (3).
 7. If the motor does not run, starter is failure. Repair or replace the starter.

■ NOTE

- **B terminal** : It is the terminal which connects the cable from the battery to the starter.
- **C terminal** : It is the terminal which connects the cable from the motor to the magnet switch.

- (1) C Terminal
 (2) Positive Terminal
 (3) Negative Terminal

[A] Electromagnetic Drive Type

[B] Planetary Gear Reduction Type

W1019297

Magnetic Switch Test

1. Disconnect the battery negative cable from the battery.
2. Disconnect the battery positive cable from the battery.
3. Disconnect the leads from the starter **B** terminal.
4. Remove the starter from the engine.
5. Connect a jumper lead from the starter **S** terminal (1) to the battery positive terminal (2).
6. Connect a jumper lead momentarily between the starter's body and the battery negative terminal (3).
7. If the pinion gear does not pop out, the magnetic switch is failure. Repair or replace the starter.

■ NOTE

- **B terminal** : It is the terminal which connects the cable from the battery to the starter.
- **S terminal** : It is the terminal which connects the cable from the starter switch to the magnet switch.

- (1) S Terminal
 (2) Positive Terminal
 (3) Negative Terminal

[A] Electromagnetic Drive Type

[B] Planetary Gear Reduction Type

0000010743E

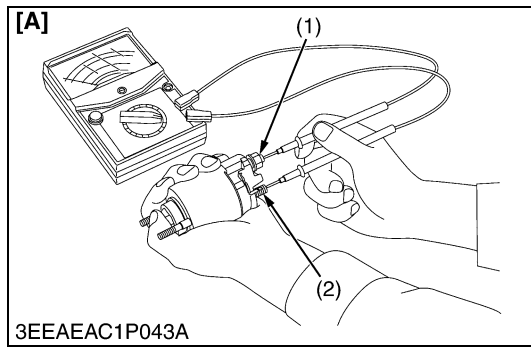

Magnet Switch Continuity Test

1. Check the continuity across the **C** terminal (1) and the **B** terminal (2) with a circuit tester, pushing in the plunger.
2. If not continuous or if a certain value is indicated, replace the magnet switch.

- (1) **C** Terminal
(2) **B** Terminal

- [A]** Electromagnetic Drive Type
[B] Planetary Gear Reduction Type

0000010771E

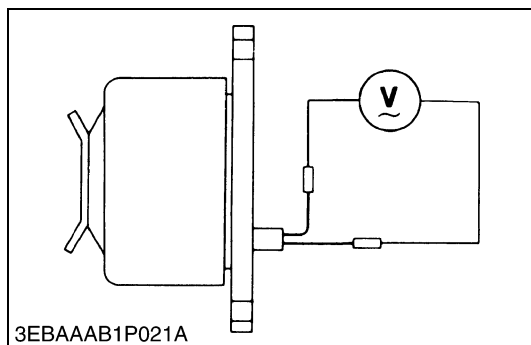
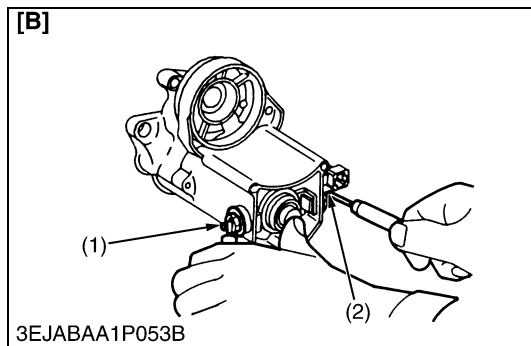

No-load Dynamo Output

1. Disconnect the lead wires from the dynamo.
2. Start the engine and operate the dynamo at the specified speed.
3. Measure the output voltage with a volt meter.
If the measurement is not within the specified values, replace the dynamo.

No-load output voltage	Factory spec.	AC 20 V or more at 5200 min ⁻¹ (rpm)
------------------------	---------------	--

W1021164

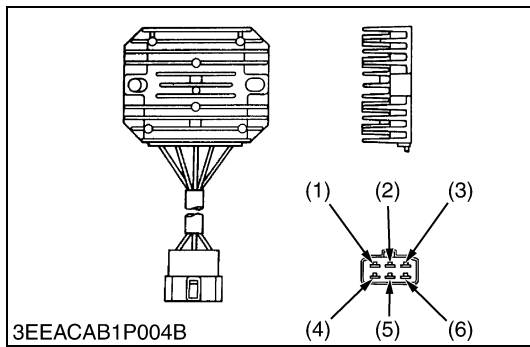

Continuity across Regulator's Terminals

1. Measure with a circuit tester according to the list below.

NOTE

- For this test, use only Analog Meter and do not use a high voltage tester such as a MΩ meter.
- This check sheet shows the results of the test conducted by using the “Sanwa-made tester SP-10 and SP-15D” (Analog Meter).
- Use of other testers than those above may show different measured results. Ω shall be used as the unit for the measuring range.
- The judgement should be as below table.
“ON” if the indicator moves, otherwise “OFF”.

Check Table (★ : ON, ☆ : OFF)

Tester + Terminal \ Tester - Terminal		Code colors					
		Blue	Black	Blue	Green	Yellow	Red
Code colors	Blue	☆	☆	☆	☆	☆	★
	Black	★		☆	☆	☆	☆
	Blue	☆	☆		☆	☆	★
	Green	☆	☆	☆		☆	☆
	Yellow	★	★	★	☆		★
	Red	☆	☆	☆	☆	☆	

- (1) Blue
- (2) Black
- (3) Blue
- (4) Green
- (5) Yellow
- (6) Red

W1021509

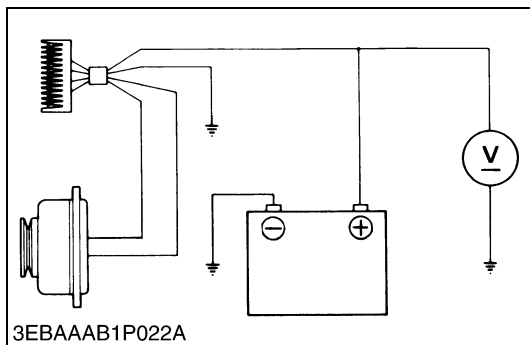

Regulating Voltage

1. Complete the charging circuit with a fully charged battery and operate the dynamo at the specified speed.
2. Measure the output voltage with a volt meter.
3. If the measurement is not within the specified values, replace the dynamo.

Regulating output voltage	Factory spec.	14 to 15 V at 5200 min ⁻¹ (rpm)
---------------------------	---------------	--

W1022299



3TMACAD9P012A

Alternator on Unit Test

(Before testing)

- Before alternator on unit test, check the battery terminal connections, circuit connection, fan belt tension, charging indicator lamp, fuses on the circuit, and abnormal noise from the alternator.
- Prepare full charged battery for the test.

■ **NOTE**

- **Be careful not to touch the rotating engine parts while engine is running.**

Keep safety distance from the engine rotating parts.

1. Start the engine.
2. When the engine is operating measure the voltage between two battery terminals. If the voltage is between 13.8 V and 14.8 V, the alternator is operating normally.
3. If the results of alternator on unit test are not within the specifications, disassemble the alternator and check the each component part for finding out the failure. See the "DISASSEMBLING AND ASSEMBLING" and "SERVICING" for alternator.

Regulating voltage at no load	Factory spec.	13.8 to 14.8 V at 25 °C (77 °F)
-------------------------------	---------------	---------------------------------

0000010745E

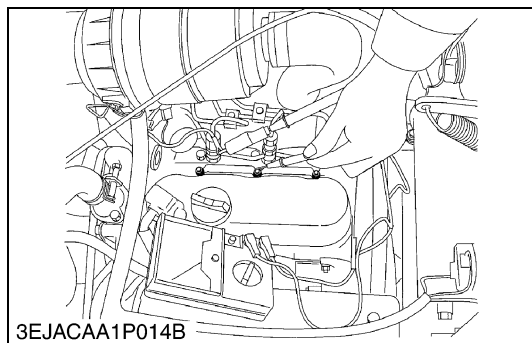

3EJACAA1P014B

Glow Plug Lead Terminal Voltage

1. Turn the key switch to the "GLOW (or PREHEAT)" position, and measure the voltage with a circuit tester between the lead terminal and the engine body.
2. If the voltage differs from the battery voltage, the wiring harness or main switch is faulty.

Voltage	Main switch key at GLOW (or PREHEAT)	Approx. battery voltage
---------	---	-------------------------

0000010725E

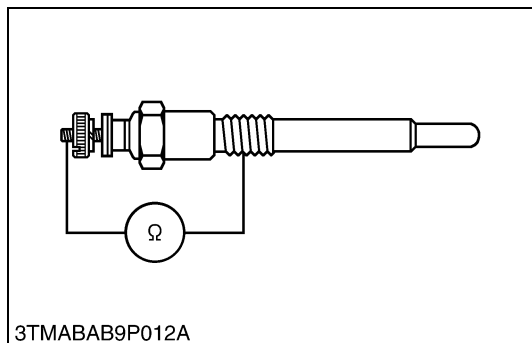

3TMABAB9P012A

Glow Plug Continuity

1. Remove the glow plug.
2. Measure the resistance with a circuit tester between the glow plug terminal and the glow plug housing.
3. If the factory specification is not indicated, glow plug is faulty.

Resistance	Factory spec.	Approx. 0.9 Ω
------------	---------------	---------------

0000010726E

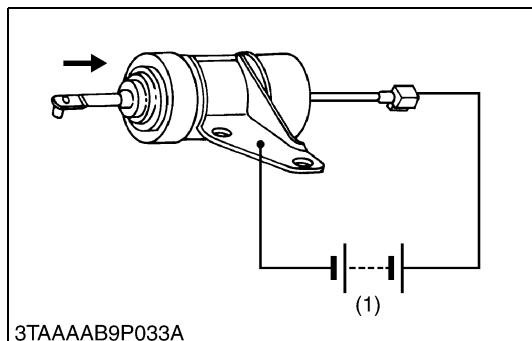

3TAAAAB9P033A

Engine Stop Solenoid Test (Energize to Stop Type)

1. Disconnect the 1P connector from the engine stop solenoid.
2. Remove the engine stop solenoid from the engine.
3. Connect the jumper leads from the battery positive terminal to the 1P connector, and from the battery negative terminal to the engine stop solenoid body.
4. If the solenoid plunger is not attracted, the engine stop solenoid is faulty.

(1) Battery (12 V)

W1019658

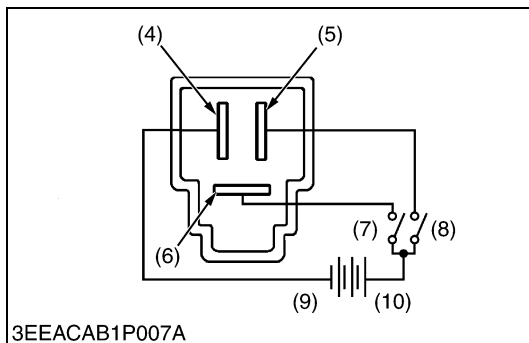
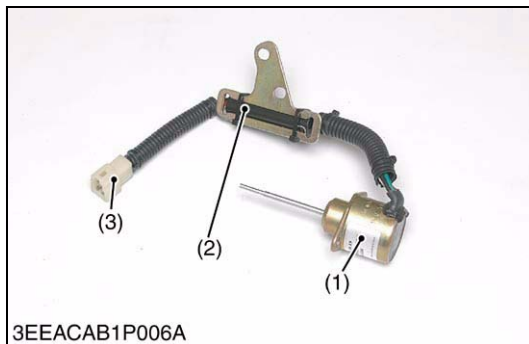
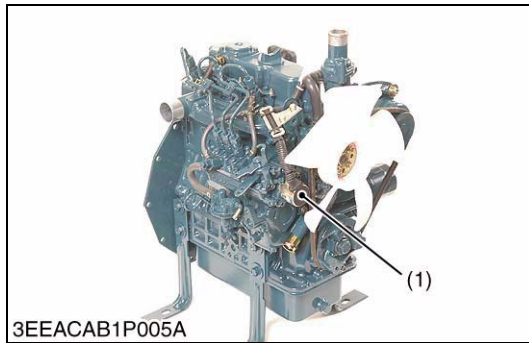

Engine Stop Solenoid Test (Energize to Run Type)

1. Disconnect the **3P** connector (3) from the engine stop solenoid (1) wiring harness.
2. Remove the engine stop solenoid (1) from the engine.
3. Connect the jumper leads from the pulling coil terminal (6) to the switch (7), and from switch (7) to the battery positive terminal (10).
4. Connect the jumper leads from the holding coil terminal (5) to the switch (8), and from switch (8) to the battery positive terminal (10).
5. Connect the jumper leads from the ground terminal (4) to the battery negative terminal (9).
6. When the switch (7) is turned on, the plunger pulls into the solenoid body and then the plunger comes out within approximately 1.2 seconds.
7. Turn on the switch (8) then turn on the switch (7), the plunger pulls into the solenoid body and it keeps in holding position after turning off the switch (7).
8. If the plunger is not attracted, the engine stop solenoid is faulty.

NOTE

- **This solenoid assembly includes reverse polarity protected pulling coil timer module (2) to prevent solenoid burnout due to engine over crank or misadjustment of linkage by limiting the pull coil ON time.**

Pull coil energized time	Factory spec.	0.52 to 1.20 seconds
--------------------------	---------------	----------------------

- | | |
|-------------------------------|--------------------------------|
| (1) Engine Stop Solenoid | (6) Pulling Coil Terminal |
| (2) Pulling Coil Timer Module | (7) Switch for Pulling Coil |
| (3) 3P Connector | (8) Switch for Holding Coil |
| (4) Ground Terminal | (9) Battery Negative Terminal |
| (5) Holding Coil Terminal | (10) Battery Positive Terminal |

W1022853

[2] DISASSEMBLING AND ASSEMBLING

(1) Draining Engine Oil and Coolant

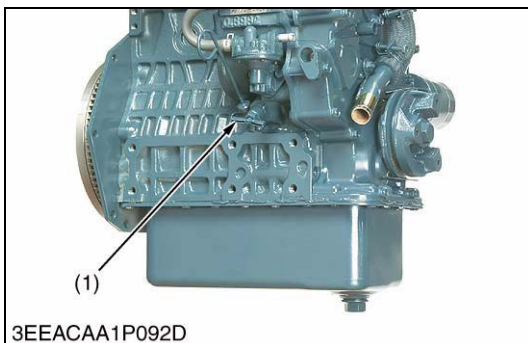
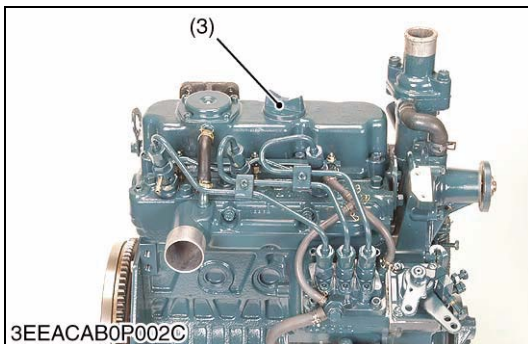
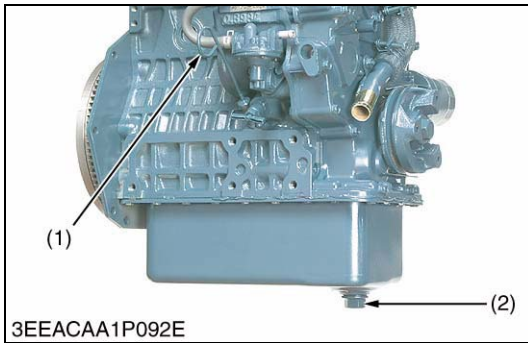

Draining Engine Oil

1. Start and warm up the engine for approx. 5 minutes.
2. Place an oil pan underneath the engine.
3. Remove the drain plug (2) to drain oil.
4. After draining, screw in the drain plug.

(When refilling)

- Fill the engine oil up to the upper line on the dipstick (1).

■ **IMPORTANT**

- **Never mix two different types of oil.**
- **Use the proper SAE Engine Oil according to ambient temperature.**

- (1) Dipstick
(2) Drain Plug

- (3) Oil Inlet Plug

W1023464

Draining Coolant

⚠ **CAUTION**

- **Never remove radiator cap while operating or immediately after stopping. Otherwise, hot water will spout out from the radiator. Wait for more than ten minutes to cool the radiator, before opening the cap.**

1. Prepare a bucket. Open the coolant drain cock.

- (1) Coolant Drain Cock

W1023496

(2) External Components

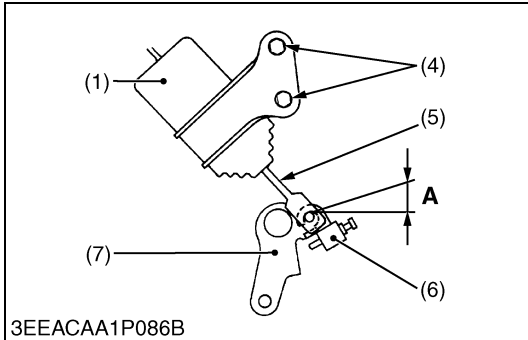
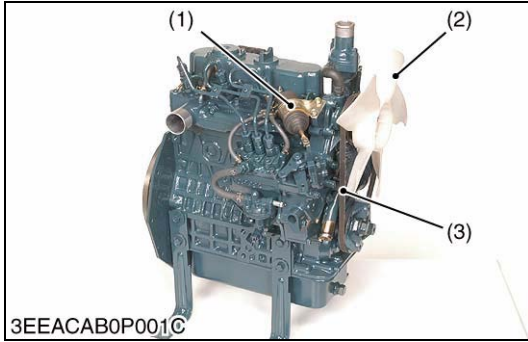

Alternator, Starter and Others

1. Remove the air cleaner and muffler.
2. Remove the engine stop solenoid (1).
3. Remove the cooling fan (2), fan pulley and fan belt (3).
4. Remove the alternator.
5. Remove the starter.

(When reassembling)

- Check to see that there are no cracks on the belt surface.

■ IMPORTANT

- **Keep the engine stop lever (7) to touch the stopper (6). Tighten the engine stop solenoid mounting screw (4) so that there be no gap between the engine stop lever and the engine stop solenoid plunger (5).**
- **After reassembling the fan belt, be sure to adjust the fan belt tension.**
- **Do not confuse the direction of the fan.**

- | | |
|---|-------------------------|
| (1) Engine Stop Solenoid | (6) Stopper |
| (2) Cooling Fan | (7) Engine Stop Lever |
| (3) Fan Belt | |
| (4) Engine Stop Solenoid Mounting Screw | A : 0 mm (0 in.) |
| (5) Plunger | |

W1023769

(3) Cylinder Head, Valves and Oil Pan

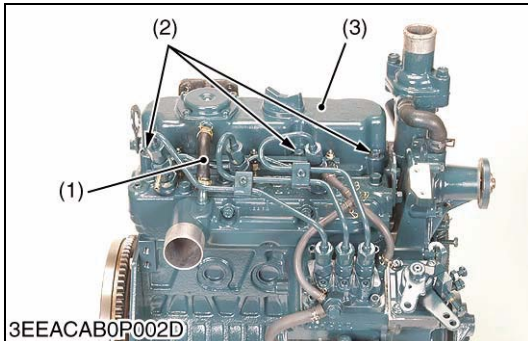

Cylinder Head Cover

1. Disconnect the breather hose (1).
2. Remove the cylinder head cover screws (2).
3. Remove the cylinder head cover (3).

(When reassembling)

- Check to see if the cylinder head cover gasket is not defective.

Tightening torque	Cylinder head cover screw	9.8 to 11.3 N·m 1.0 to 1.15 kgf·m 7.2 to 8.3 ft-lbs
-------------------	---------------------------	---

- | | |
|--------------------------------|-------------------------|
| (1) Breather Hose | (3) Cylinder Head Cover |
| (2) Cylinder Head Cover Screws | |

W1028468

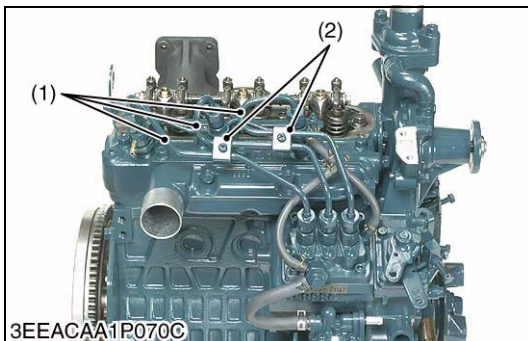

Injection Pipes

1. Loosen the screws to the pipe clamp (2).
2. Detach the injection pipes (1).

(When reassembling)

- Sent compressed air into the pipes to blow out dust. Then, reassemble the pipes in the reverse order.

Tightening torque	Injection pipe retaining nut	24.5 to 34.3 N·m 2.5 to 3.5 kgf·m 18.1 to 25.3 ft-lbs
-------------------	------------------------------	---

- | | |
|--------------------|----------------|
| (1) Injection Pipe | (2) Pipe Clamp |
|--------------------|----------------|

W1028640

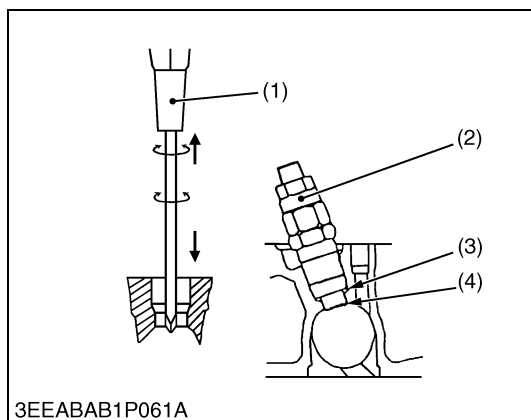
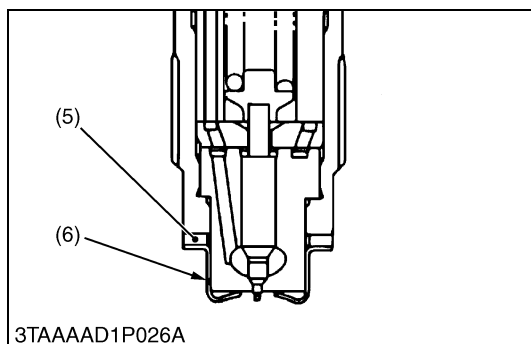
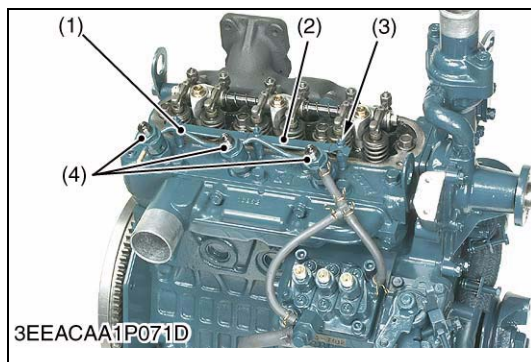

Nozzle Holder Assembly and Glow Plug

1. Remove the overflow pipe (1).
2. Remove the nozzle holder assemblies (4).
3. Remove the copper gasket (5) and heat seal (6).
4. Remove the lead (2) from the glow plugs (3).
5. Remove the glow plugs (3).

(When reassembling)

- Replace the copper gasket and heat seal with new one.

Tightening torque	Overflow pipe retaining nut	19.6 to 24.5 N·m 2.0 to 2.5 kgf·m 14.5 to 18.1 ft-lbs
	Nozzle holder assembly	49.0 to 68.6 N·m 5.0 to 7.0 kgf·m 36.2 to 50.6 ft-lbs
	Glow plug	7.8 to 14.7 N·m 0.8 to 1.5 kgf·m 5.8 to 10.8 ft-lbs

- | | |
|-------------------|----------------------------|
| (1) Overflow Pipe | (4) Nozzle Holder Assembly |
| (2) Lead | (5) Copper Gasket |
| (3) Glow Plug | (6) Heat Seal |

W1024604

Nozzle Heat Seal Service Removal Procedure

■ IMPORTANT

- Use a plus (phillips head) screw driver (1) that has a diameter which is bigger than the heat seal hole (Approx. 6 mm (1/4 in.)).

1. Drive screw driver (1) lightly into the heat seal hole.
2. Turn screw driver three or four times each way.
3. While turning the screw driver, slowly pull the heat seal (4) out together with the injection nozzle gasket (3).
4. If the heat seal drops, repeat the above procedure.

(When reassembling)

- Heat seal and injection nozzle gasket must be changed when the injection nozzle is removed for cleaning or for service.

- | | |
|-----------------------|-----------------------------|
| (1) Plus Screw Driver | (3) Injection Nozzle Gasket |
| (2) Injection Nozzle | (4) Heat Seal |

W1021255

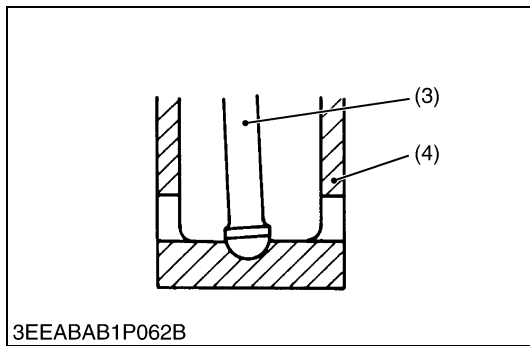
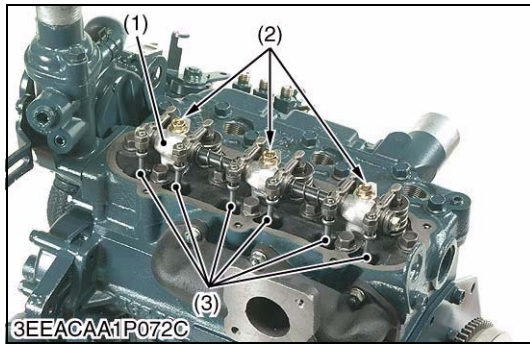

Rocker Arm and Push Rod

1. Remove the rocker arm bracket screws (2).
2. Detach the rocker arm assembly (1).
3. Remove the push rods (3).

(When reassembling)

- When putting the push rods (3) onto the tappets (4), check to see if their ends are properly engaged with the dimples.

■ IMPORTANT

- **After installing the rocker arm, be sure to adjust the valve clearance.**

Tightening torque	Rocker arm bracket screw	9.8 to 11.3 N·m 1.00 to 1.15 kgf·m 7.2 to 8.3 ft-lbs
-------------------	--------------------------	--

(1) Rocker Arm Assembly

(2) Rocker Arm Bracket Screws

(3) Push Rod

(4) Tappet

W1021437

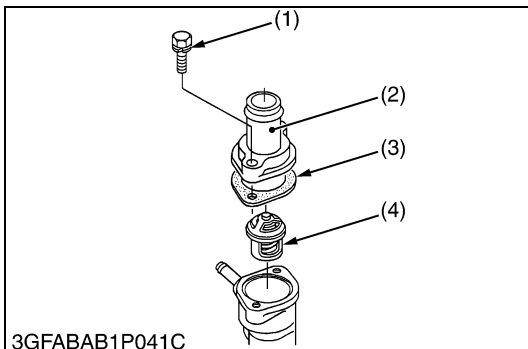
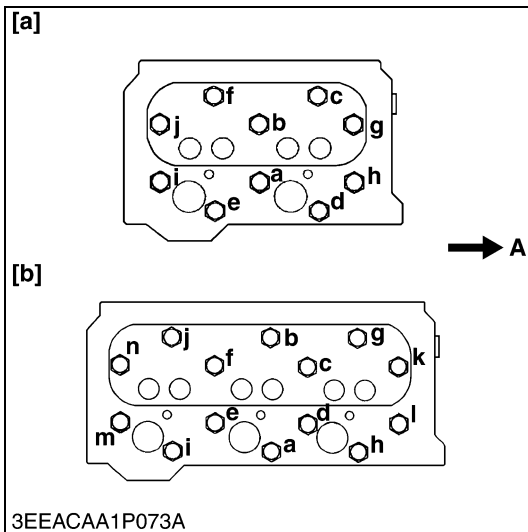
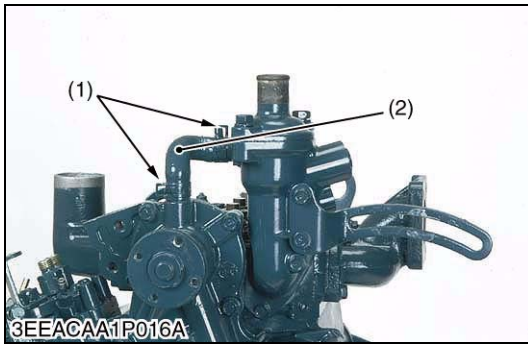

Cylinder Head

1. Loosen the pipe clamps (1), and remove the water return pipe (2).
2. Remove the cylinder head screw in the order of (n or j) to (a).
3. Lift up the cylinder head to detach.
4. Remove the cylinder head gasket and O-ring (3).

(When reassembling)

- Replace the cylinder head gasket with a new one.
- Securely fit the O-ring (3) to the pipe pin.
- Tighten the cylinder head screws after applying sufficient oil.
- Tighten the cylinder head screws in order of (a) to (n or j).
- Tighten them uniformly, or the head may deform in the long run.
- Retighten the cylinder head screws after running the engine for 30 minutes.

Tightening torque	Cylinder head screw	37.3 to 42.2 N·m 3.8 to 4.3 kgf·m 27.5 to 31.1 ft·lbs
-------------------	---------------------	---

- (1) Pipe Clamp
(2) Water Return Pipe
(3) O-ring

A : Gear Case Side

(n or j) to (a) : To Loosen

(a) to (n or j) : To Tighten

[a] Z482-E2B, Z602-E2B

[b] D662-E2B, D722-E2B,
D782-E2B, D902-E2B

W1025645

Thermostat Assembly

1. Remove the thermostat cover mounting screws (1), and remove the thermostat cover (2).
2. Remove the thermostat assembly (4).

(When reassembling)

- Apply a liquid gasket (Three Bond 1215 or equivalent) only at the thermostat cover side of the gasket (3).

- (1) Thermostat Cover Mounting Screw (3) Thermostat Cover Gasket
(2) Thermostat Cover (4) Thermostat Assembly

W10363950

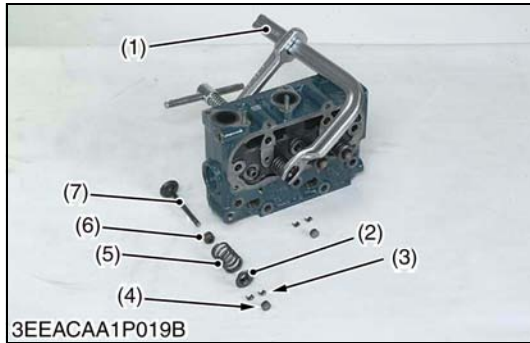

Tappets

1. Remove the tappets (1) from the crankcase.

(When reassembling)

- Visually check the contact between tappets and cams for proper rotation. If defect is found, replace tappets.
- Before installing the tappets, apply engine oil thinly around them.

■ **IMPORTANT**

- **Do not change the combination of tappet and tappet guide.**

- (1) Tappet

W10209700

Valves

1. Remove the valve caps (4).
2. Remove the valve spring collet (3), pushing the valve spring retainer (2) by valve spring replacer (1).
3. Remove the valve spring retainer (2), valve spring (5) and valve stem seal (6).
4. Remove the valve (7).

(When reassembling)

- Wash the valve stem and valve guide hole, and apply engine oil sufficiently.
- After installing the valve spring collets, lightly tap the stem to assure proper fit with a plastic hammer.

■ **IMPORTANT**

- **Don't change the combination of valve and valve guide.**

- | | |
|---------------------------|---------------------|
| (1) Valve Spring Replacer | (5) Valve Spring |
| (2) Valve Spring Retainer | (6) Valve Stem Seal |
| (3) Valve Spring Collet | (7) Valve |
| (4) Valve Cap | |

W10211070

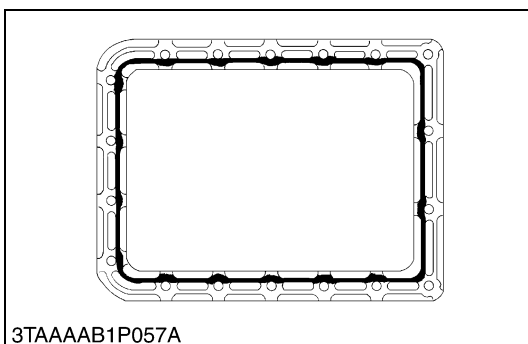
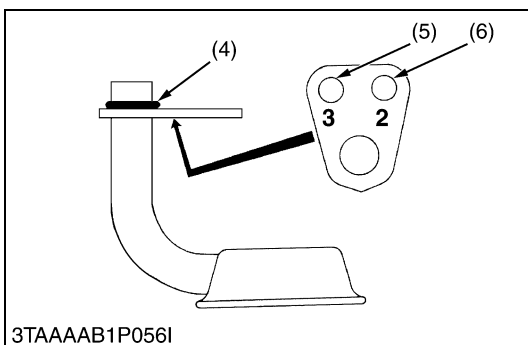

Oil Pan and Oil Strainer

1. Remove the oil pan mounting screws (2).
2. Remove the oil pan (1) by lightly tapping the rim of the pan with a wooden hammer.
3. Remove the oil strainer (3).

(When reassembling)

- After cleaning the oil strainer, check to see that the filter mesh is clean, and install it.
- Visually check the O-ring (4), apply engine oil, and install it.
- Securely fit the O-ring to the oil strainer.
- To avoid uneven tightening, tighten oil pan mounting screws in diagonal order from the center.

For Z482-E2B, Z602-E2B

- Using the hole (6) numbered "2", install the oil strainer by mounting screw

For D662-E2B, D722-E2B, D782-E2B, D902-E2B

- Using the hole (5) numbered "3", install the oil strainer by mounting screw

■ IMPORTANT

- **Scrape off the old adhesive completely. Wipe the sealing surface clean using waste cloth soaked with gasoline. Now apply new adhesive 3 to 5 mm (0.12 to 0.20 in.) thick all over the contact surface. Apply the adhesive also on the center of the flange as well as on the inner wall of each bolt hole.**
- **Cut the nozzle of the "liquid gasket" (Three Bond 1207D or equivalent) container at its second notch. Apply "liquid gasket" about 3 to 5 mm (0.12 to 0.20 in.) thick. Within 20 minutes after the application of fluid sealant, reassemble the components. Wait then for about 30 minutes, and pour oil in the crankcase.**

- | | |
|----------------------------|-------------------------|
| (1) Oil Pan | [a] Z482-E2B, Z602-E2B |
| (2) Oil Pan Mounting Screw | [b] D662-E2B, D722-E2B, |
| (3) Oil Strainer | D782-E2B, D902-E2B |
| (4) O-ring | |
| (5) Hole Numbered "3" | |
| (6) Hole Numbered "2" | |

W10236610

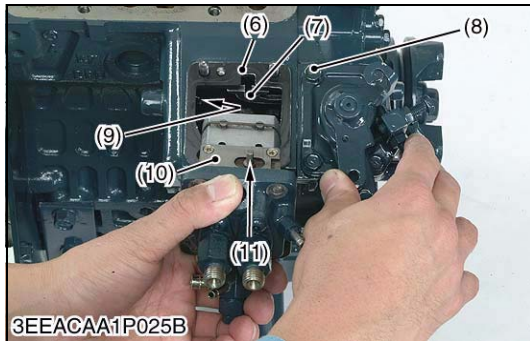
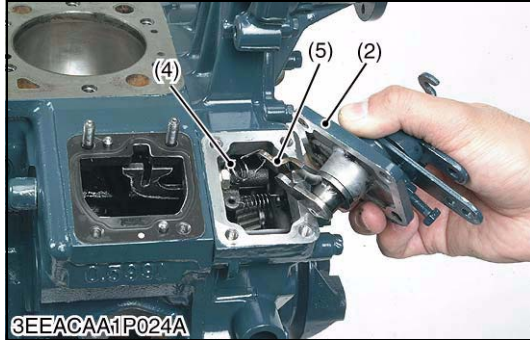
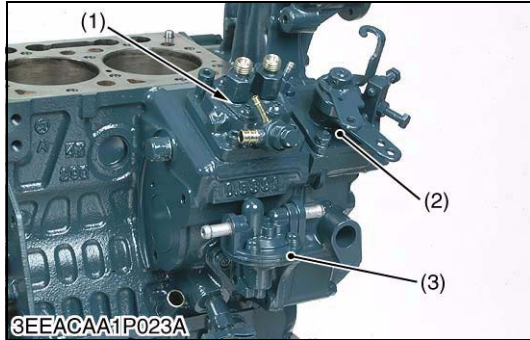
(4) Gear Case and Timing Gears**Injection Pump, Fuel Feed Pump and Speed Control Plate (for Energize to Stop Type Engine Stop Solenoid)**

1. Remove the socket head screws and nuts, and remove the injection pump (1).
2. Remove the screws and separate the speed control plate (2), taking care not to damage the governor spring (4).
3. Disconnect the governor spring (4) and remove the speed control plate (2).
4. Remove the fuel feed pump (3).

(When reassembling)

- Hook the governor spring (4) to the governor lever (5) first and install the speed control plate (2).
- Be sure to place the copper washers underneath two screws (8). (Two screws (8) in the upper of the speed control plate (2).)
- Position the slot (7) on the fork lever just under the slot (6) on the crankcase.
- Insert the injection pump (1) so that the control rod (10) should be pushed by the idling adjusting spring (9) at its end and the pin (11) on the rod engages with the slot (7) on the fork lever (as shown in the photo).

■ NOTE

- **The sealant is applied to both sides of the soft metal gasket shim. The liquid gasket is not required for assembling.**
- **Addition or reduction of shim (0.05 mm, 0.0020 in.) delays or advances the injection timing by approx. 0.0087 rad (0.5 °).**
- **In disassembling and replacing, be sure to use the same number of new gasket shims with the same thickness.**

- | | |
|---------------------------|-----------------------------|
| (1) Injection Pump | (7) Slot (Fork Lever Side) |
| (2) Speed Control Plate | (8) Screw and Copper Washer |
| (3) Fuel Feed Pump | (9) Idling Adjusting Spring |
| (4) Governor Spring | (10) Control Rod |
| (5) Governor Lever | (11) Pin |
| (6) Slot (Crankcase Side) | |

W1027230

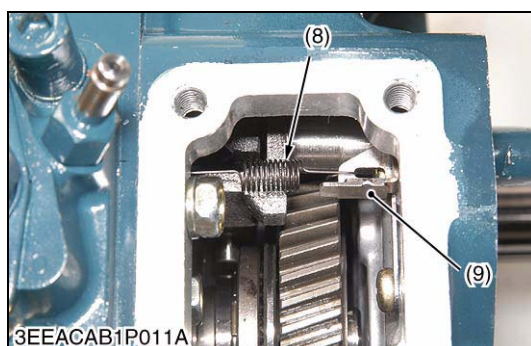
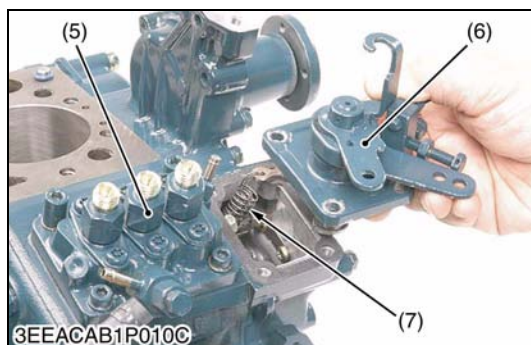
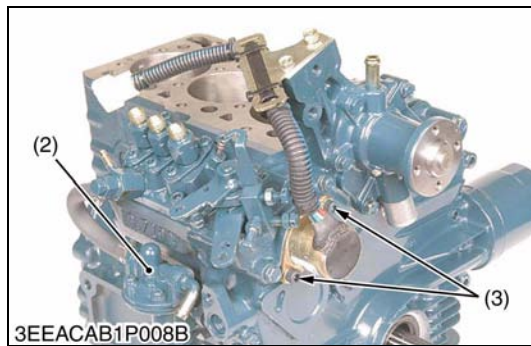
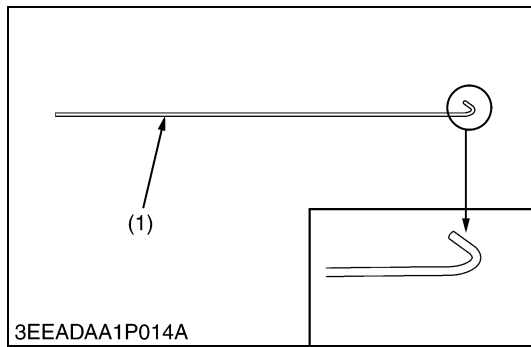

Injection Pump, Fuel Feed Pump and Speed Control Plate (for Energize to Run Type Engine Stop Solenoid)

■ NOTE

- Specific tool (1) :

1.2 mm diameter hard wire with its end hooked, overall length 200 mm (7.87 in.).

The tip of wire is bent like the hook to hang governor springs.

1. Remove the socket head screws (3), and remove the engine stop solenoid (4).
2. Remove the screws and separate the speed control plate (6), taking care not to damage the governor spring (7).
3. Disconnect the governor spring (7) and remove the speed control plate (6) using the specific tool (1).
4. Remove the fuel feed pump (2).
5. Disconnect the start spring (8) from the bracket (9) using the specific tool (1).
6. Remove the socket head screws and nuts, and remove the injection pump (5).

- (1) Specific Tool
 (2) Fuel Feed Pump
 (3) Socket Head Screw
 (4) Engine Stop Solenoid
 (5) Injection Pump

- (6) Speed Control Plate
 (7) Governor Spring
 (8) Start Spring
 (9) Bracket

W1148604

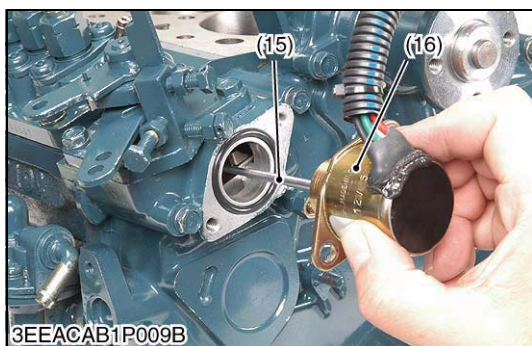
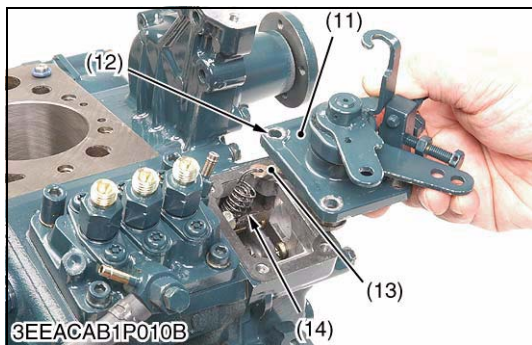
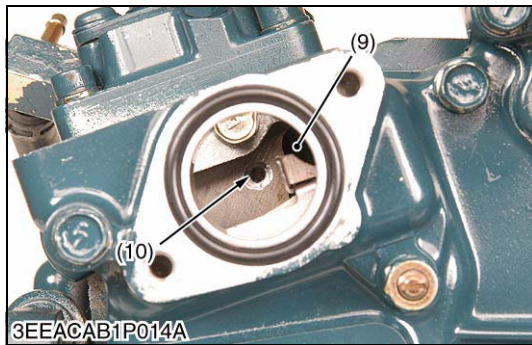
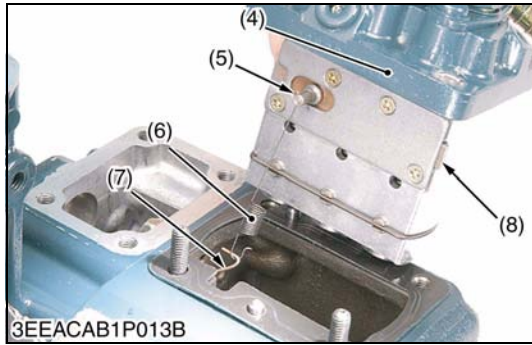
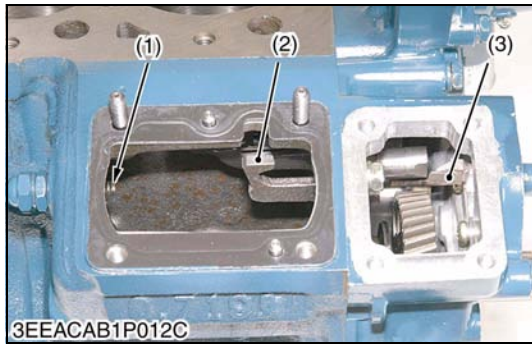

Injection Pump, Fuel Feed Pump and Speed Control Plate (for Energize to Run Type Engine Stop Solenoid) (Continued) (When reassembling)

1. Move the fork lever (2) to the gear case side.
2. Hook the start spring (6) to the injection pump control rack pin (5).
3. Put the specific tool (7) through the fork lever hole of cylinder block (9) and hook the start spring (6).
4. Keep this spring slightly extended and install the injection pump (4). Make sure the control rod (8) should be pushed by the idling adjusting spring (1) and the pin (5) on the rod engages with the fork lever (2).
5. Hook the start spring (6) to the bracket (3) using the specific tool (7).
6. Hook the governor springs (small and large) (14) to the governor lever (13) using the specific tool (7) and install the speed control plate (11). Be sure to place the copper washers underneath two screws (12) in the upper of the speed control plate.
7. Install the engine stop solenoid rod (15) to the guide hole of cylinder block (10) and fix the engine stop solenoid (16) with socket head screws.

NOTE

- Be careful not to stretch the start spring (6) too long. Otherwise it may get deformed permanently.
- Make sure the start spring (6) is tight on the bracket (3).
- The sealant is applied to both sides of the soft metal gasket shim. The liquid gasket is not required for assembling.
- Addition or reduction of shim (0.05 mm, 0.0020 in.) delays or advances the injection timing by approx. 0.0087 rad (0.5 °).
- In disassembling and replacing, be sure to use the same number of new gasket shims with the same thickness.

- | | |
|-------------------------------------|---------------------------------------|
| (1) Idling Adjusting Spring | (9) Fork Lever Hole of Cylinder Block |
| (2) Fork Lever | (10) Guide Hole of Cylinder Block |
| (3) Bracket | (11) Speed Control Plate |
| (4) Injection Pump | (12) Screw and Copper Washer |
| (5) Injection Pump Control Rack Pin | (13) Governor Lever |
| (6) Start Spring | (14) Governor Spring |
| (7) Specific Tool | (15) Engine Stop Solenoid Rod |
| (8) Injection Pump Control Rod | (16) Engine Stop Solenoid |

W1028534

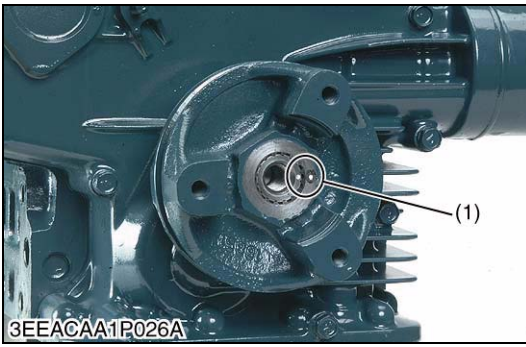

Fan Drive Pulley

1. Secure the flywheel to keep it from turning.
2. Remove the fan drive pulley screw.
3. Draw out the fan drive pulley with a puller.

(When reassembling)

- Install the pulley to crankshaft, aligning the mark (1) on them.
- Apply engine oil to the fan drive pulley retaining screw. And tighten it.

Tightening torque	Fan drive pulley screw	117.7 to 127.5 N·m 12.0 to 13.0 kgf·m 86.8 to 94.0 ft-lbs
-------------------	------------------------	---

(1) Alignment Mark

W10181950

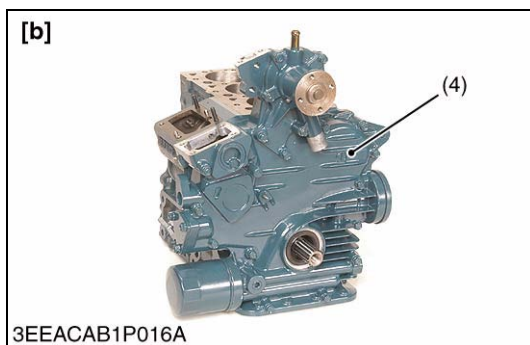
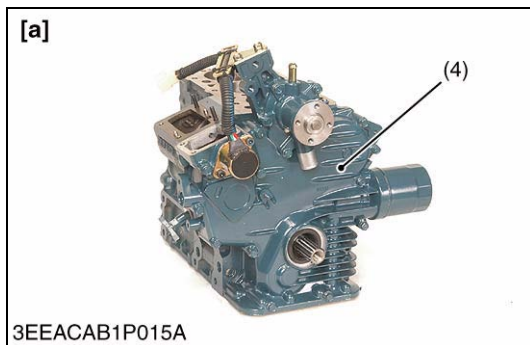
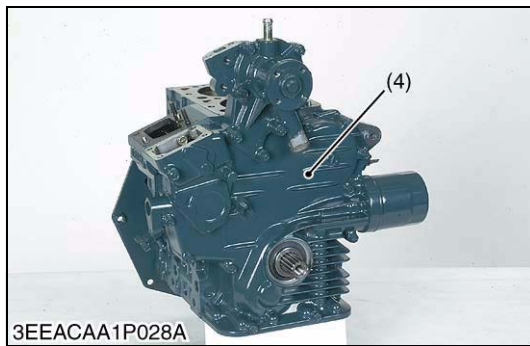
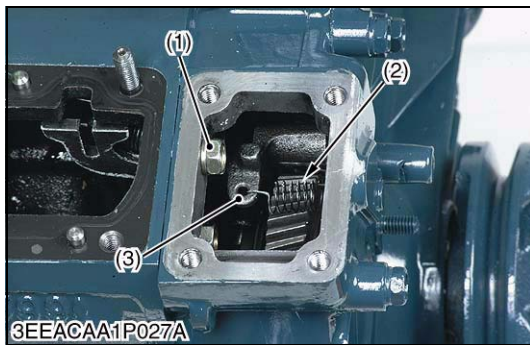

Gear Case

1. Disconnect the start spring (2) from the fork lever 1 (3).
2. Remove the screw (1) of inside the gear case and outside screws.
3. Remove the gear case (4).

(When reassembling)

- Apply a liquid gasket (Three Bond 1215 or equivalent) to both sides of the gear case gasket.
- Be sure to set three O-rings inside the gear case.

■ NOTE

- **The gear case for energize to run type stop solenoid and the gear case for one-side maintenance are available to meet customer's requirements. (Option)**

- (1) Screw (Inside)
- (2) Start Spring
- (3) Fork Lever 1
- (4) Gear Case

[a] Gear Case for Energize to Run Type Stop Solenoid (Option)

[b] Gear Case for One-side Maintenance (Option)

W1029858

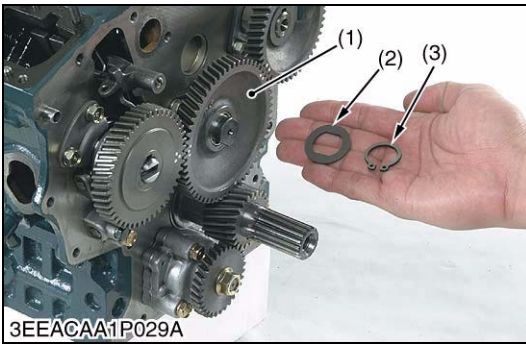
**Idle Gear**

1. Remove the external snap ring (3), the collar (2) and the idle gear (1).
2. Remove the idle gear shaft mounting screws (4).
3. Remove the idle gear shaft (5) (if necessary).

(When reassembling)

- Apply engine oil to the idle gear shaft mounting screw (4). And tighten them.
- Install the idle gear, aligning the mark (6) on the gears referring to the photo.

Tightening torque	Idle gear shaft mounting screw	9.8 to 11.3 N·m 1.00 to 1.15 kgf·m 7.2 to 8.3 ft·lbs
-------------------	--------------------------------	--

- | | |
|------------------------|------------------------------------|
| (1) Idle Gear | (4) Idle Gear Shaft Mounting Screw |
| (2) Idle Gear Collar | (5) Idle Gear Shaft |
| (3) External Snap Ring | (6) Alignment Mark |

W1030437

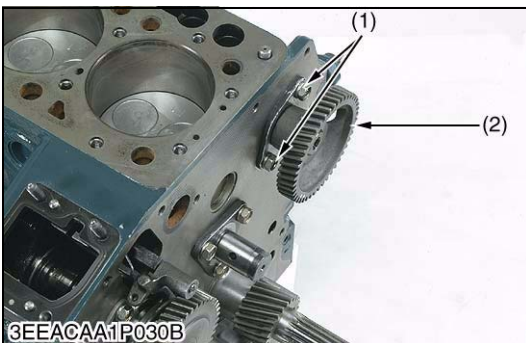
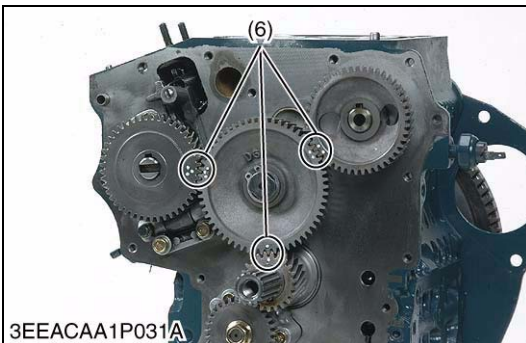
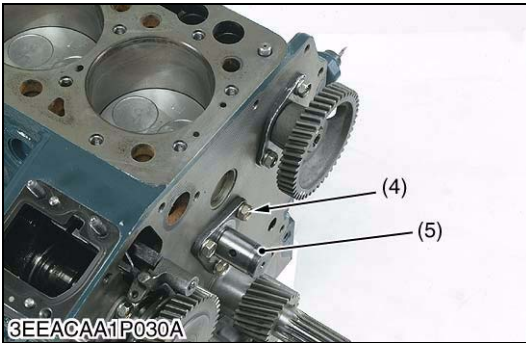
**Camshaft**

1. Remove the camshaft mounting screws (1) and draw out the camshaft with gear (2) on it.

(When reassembling)

- When install the camshaft, apply engine oil to the camshaft journals.
- Apply engine oil to the camshaft mounting screws. And tighten them.

- | | |
|-----------------------------|-------------------|
| (1) Camshaft Mounting Screw | (2) Camshaft Gear |
|-----------------------------|-------------------|

W1030808

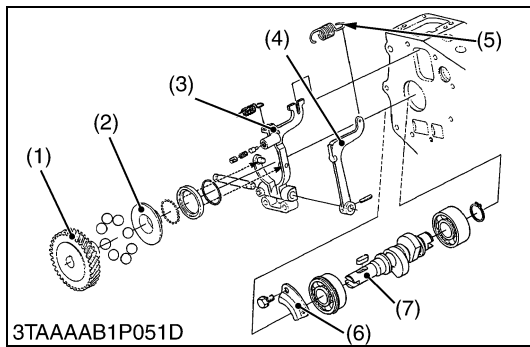

Fuel Camshaft

1. Remove the retaining plate (6).
2. Remove the fork lever holder mounting screws (8), then draw out the injection pump gear (1) and fuel camshaft (7) with the governor fork assembly.

(When reassembling)

- Hook the governor spring (5) to the fork lever 2 (4) before installing the fork lever assembly to the crankcase.

- | | |
|-------------------------|--------------------------------------|
| (1) Injection Pump Gear | (5) Governor Spring |
| (2) Governor Sleeve | (6) Retaining Plate |
| (3) Fork Lever 1 | (7) Fuel Camshaft |
| (4) Fork Lever 2 | (8) Fork Lever Holder Mounting Screw |

W10178820

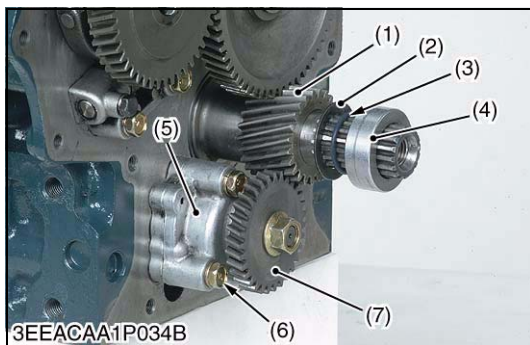
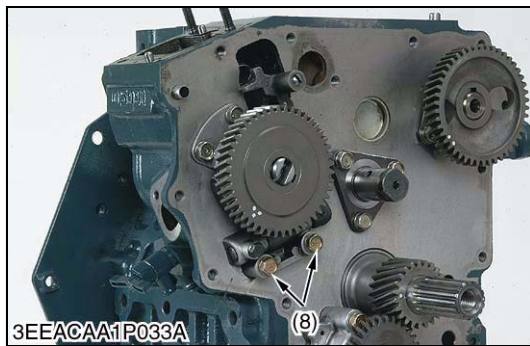

Oil Pump and Crankshaft Gear

1. Remove the oil pump gear (7).
2. Remove the oil pump mounting screw (6) and the oil pump (5).
3. Remove the collar (4), O-ring (3) and crankshaft oil slinger (2).

For Z482-E2B, D662-E2B, D722-E2B, D782-E2B

4. Remove the crankshaft gear (1) with a puller.

(When reassembling)

- Install the collar (4) after aligning the marks on the gears. (See the photo at "Idle Gear".)

Tightening torque	Oil pump mounting screw	17.7 to 21.6 N·m 1.80 to 2.20 kgf·m 13.0 to 15.9 ft-lbs
-------------------	-------------------------	---

- | | |
|----------------------------|-----------------------------|
| (1) Crankshaft Gear | (5) Oil Pump |
| (2) Crankshaft Oil Slinger | (6) Oil Pump Mounting Screw |
| (3) O-ring | (7) Oil Pump Gear |
| (4) Crankshaft Collar | |

W10180290

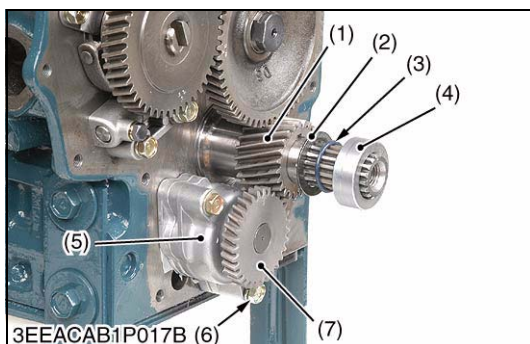

Oil Pump and Crankshaft Gear (One-side Maintenance Type)

1. Remove the oil pump mounting screw (6) and the oil pump (5).
2. Remove the collar (4), O-ring (3) and crankshaft oil slinger (2).

For Z482-E2B, D662-E2B, D722-E2B, D782-E2B

3. Remove the crankshaft gear (1) with a puller.

(When reassembling)

- Install the collar (4) after aligning the marks on the gears. (See the photo at "Idle Gear".)

Tightening torque	Oil pump mounting screw	17.7 to 21.6 N·m 1.80 to 2.20 kgf·m 13.0 to 15.9 ft-lbs
-------------------	-------------------------	---

- | | |
|----------------------------|-----------------------------|
| (1) Crankshaft Gear | (5) Oil Pump |
| (2) Crankshaft Oil Slinger | (6) Oil Pump Mounting Screw |
| (3) O-ring | (7) Oil Pump Gear |
| (4) Crankshaft Collar | |

W10314010

(5) Piston and Connecting Rod

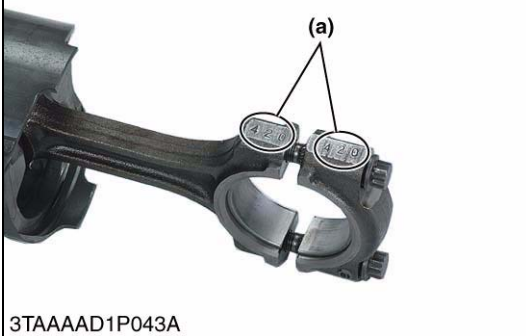

Connecting Rod Cap

1. Remove the connecting rod caps (1) using a bihexagonal 8 mm socket.

(When reassembling)

- Align the marks **(a)** with each other. (Face the marks toward the injection pump.)
- Apply engine oil to the connecting rod screws and lightly screw it in by hand, then tighten it to the specified torque.

If the connecting rod screw won't be screwed in smoothly, clean the threads.

If the connecting rod screw is still hard to screw in, replace it.

Tightening torque	Connecting rod screw	26.5 to 30.4 N·m 2.7 to 3.1 kgf·m 19.5 to 22.4 ft-lbs
-------------------	----------------------	---

(1) Connecting Rod Cap

(a) Mark

W10275480

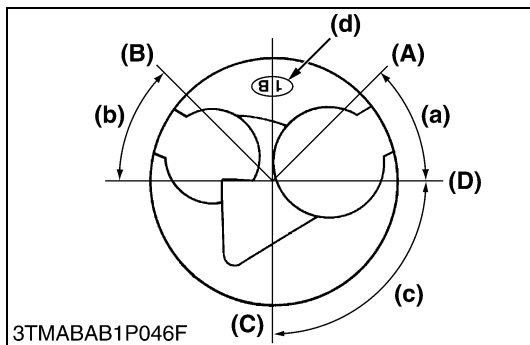
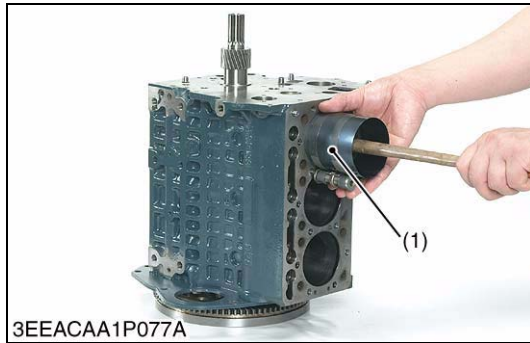
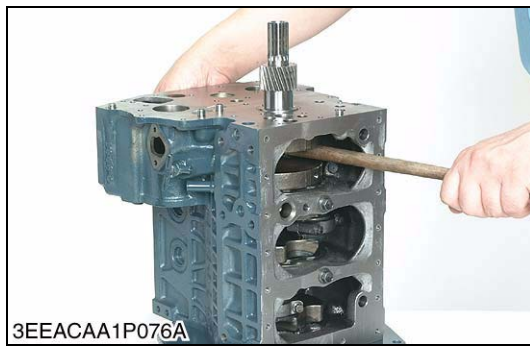

Piston

1. Turn the flywheel and bring the piston to top dead center.
2. Draw out the piston upward by lightly tapping it from the bottom of the crankcase with the grip of a hammer.
3. Draw out the other pistons after the same method as above.

(When reassembling)

- Before inserting the piston into the cylinder, apply enough engine oil to the cylinder.
- When inserting the piston into the cylinder, face the mark on the connecting rod to the injection pump.

■ IMPORTANT

- Do not change the combination of cylinder and piston. Make sure of the position of each piston by marking. For example, mark "1" on the No. 1 piston.
- When installing the piston into the cylinder, place the gaps of all of the piston rings as shown in the figure.
- Carefully insert the piston using a piston ring compressor (1). Otherwise, their chrome-plated section may be scratched, causing trouble inside the cylinder.

Models	Mark
Z482-E2B, D722-E2B	3
D662-E2B	4
D782-E2B	A
Z602-E2B, D902-E2B (3200 min ⁻¹ (rpm) spec.)	2A
Z602-E2B, D902-E2B (3600 min ⁻¹ (rpm) spec.)	1B

- (1) Piston Ring Compressor
(A) Top Ring Gap
(B) Second Ring Gap
(C) Oil Ring Gap
(D) Piston Pin Hole

- (a) 0.785 rad (45 °)**
(b) 0.785 rad (45 °)
(c) 1.57 rad (90 °)
(d) Mark

W10277450

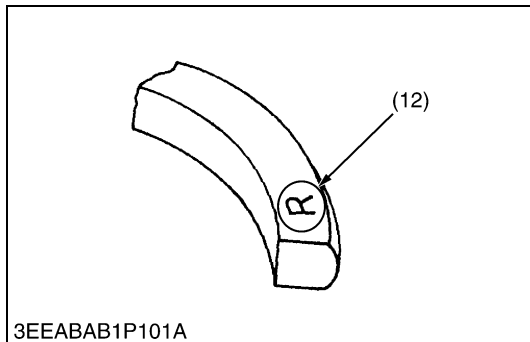
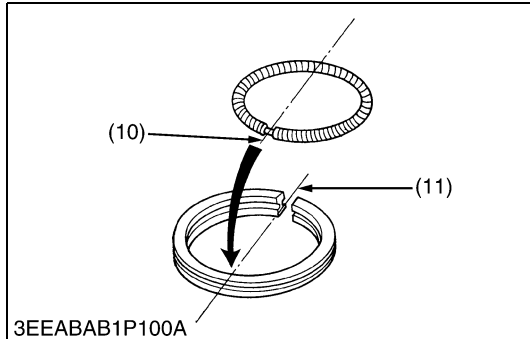
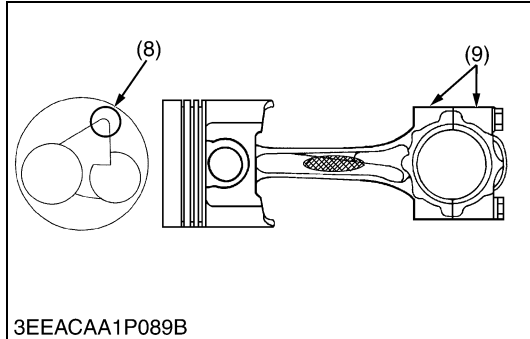
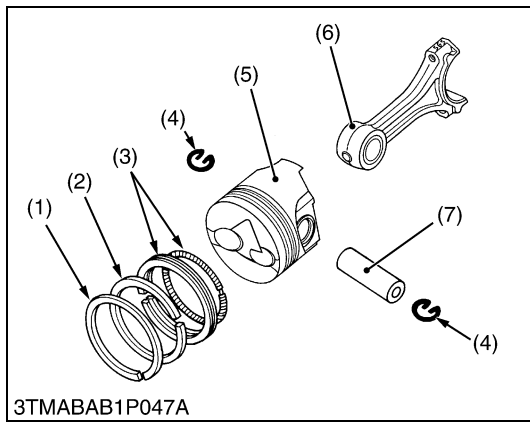

Piston Ring and Connecting Rod

1. Remove the piston rings using a piston ring tool.
2. Remove the piston pin (7), and separate the connecting rod (6) from the piston (5).

(When reassembling)

- When installing the ring, assemble the rings so that the manufacturer's mark (12) near the gap faces the top of the piston.
- When installing the oil ring onto the piston, place the expander joint (10) on the opposite side of the oil ring gap (11).
- Apply engine oil to the piston pin.
- When installing the connecting rod to the piston, immerse the piston in 80 °C (176 °F) oil for 10 to 15 minutes and insert the piston pin to the piston.
- When installing the connecting rod to the piston, align the mark (9) on the connecting rod to the fan-shaped concave (8).

■ IMPORTANT

- **Mark the same number on the connecting rod and the piston so as not to change the combination.**

- | | |
|--------------------------|--------------------------|
| (1) Top Ring | (7) Piston Pin |
| (2) Second Ring | (8) Fan-Shaped Concave |
| (3) Oil Ring | (9) Mark |
| (4) Piston Pin Snap Ring | (10) Expander Joint |
| (5) Piston | (11) Oil Ring Gap |
| (6) Connecting Rod | (12) Manufacturer's Mark |

W10281670

(6) Flywheel and Crankshaft

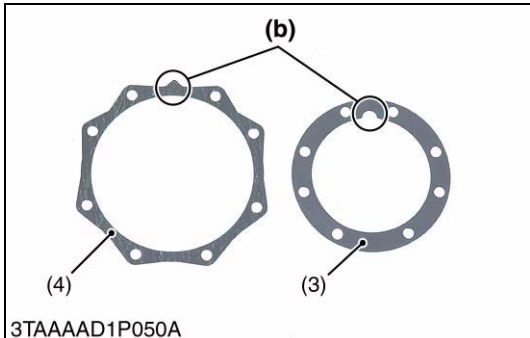
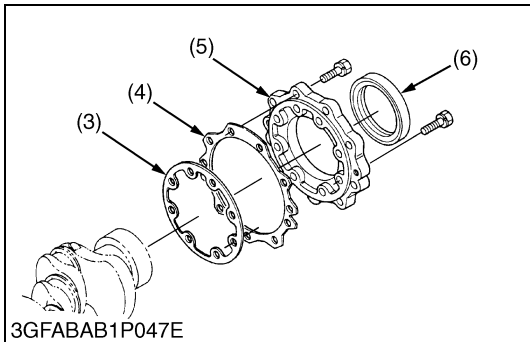
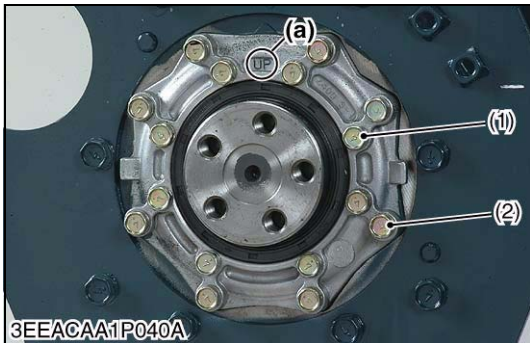
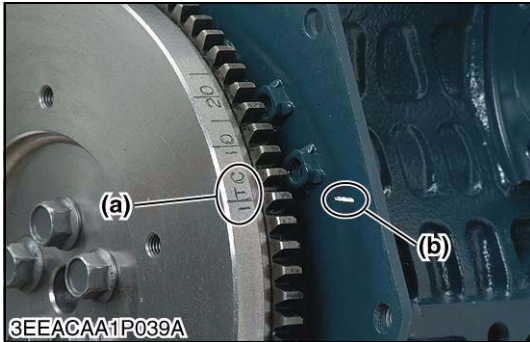

Flywheel

1. Secure the flywheel to keep it from turning using a flywheel stopper. (Refer to “**SPECIAL TOOLS**”.)
2. Remove all flywheel screws (1) and then remove the flywheel (2).

(When reassembling)

- Set the No. 1 crankpin at the top dead center (T.D.C.).
- Align the “**1TC**” mark **(a)** on the outer surface of the flywheel horizontally with the alignment mark **(b)** on the rear end plate.
- Apply engine oil to the threads and the undercut surface of the flywheel screw and fit the screw.

Tightening torque	Flywheel screw	53.9 to 58.8 N·m 5.5 to 6.0 kgf·m 39.8 to 43.4 ft·lbs
-------------------	----------------	---

- (1) Flywheel Screw
- (2) Flywheel

- (a) 1TC Mark**
- (b) Alignment Mark**

W1030810

Bearing Case Cover

1. Remove the bearing case cover mounting screws. First, remove inside screws (1) and then outside screws (2).
2. Remove the bearing case cover (5).

(When reassembling)

- Fit the bearing case gasket (3) and the bearing case cover gasket (4) with correct directions.
- Install the bearing case cover (5) to position the casting mark “UP” **(a)** on it upward.
- Apply engine oil to the oil seal (6) lip and take care that it is not rolled when installing.
- Tighten the bearing case cover mounting screws with even force on the diagonal line.

Tightening torque	Bearing case cover mounting screw	9.8 to 11.3 N·m 1.00 to 1.15 kgf·m 7.2 to 8.3 ft·lbs
-------------------	-----------------------------------	--

- (1) Bearing Case Cover Mounting Screw (Inside)
- (2) Bearing Case Cover Mounting Screw (Outside)
- (3) Bearing Case Gasket
- (4) Bearing Case Cover Gasket
- (5) Bearing Case Cover
- (6) Oil Seal
- (a) Top Mark “UP”**
- (b) Upside**

W1031168

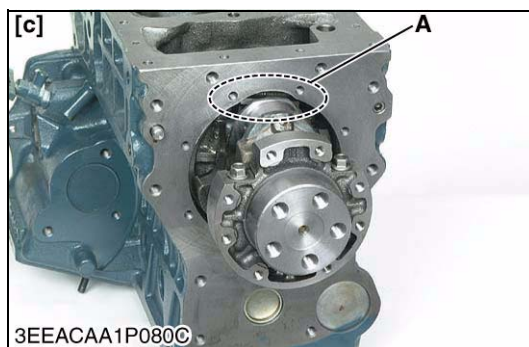
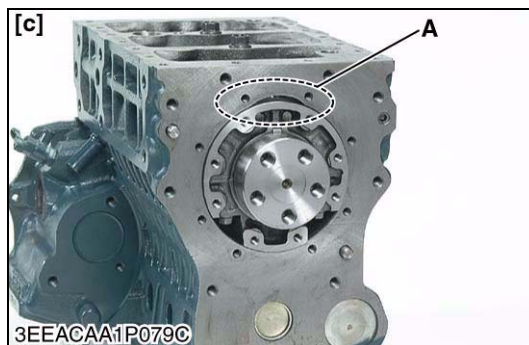
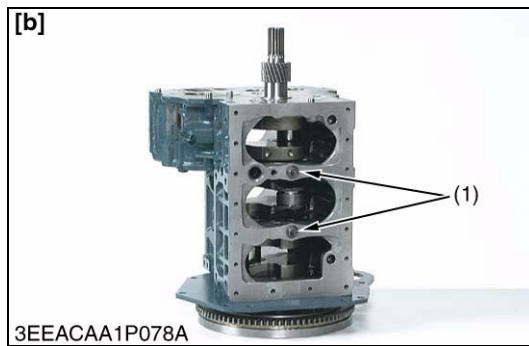

Crankshaft Assembly

For Z482-E2B, D662-E2B, D722-E2B

1. Remove the main bearing case screw 2 (1).
2. Draw out all the crankshaft.

For Z602-E2B

1. Remove the main bearing case screw 2 (1).
2. Turn the crankshaft to set the crankpin of the cylinder to the horizontal directions (right or left). Then draw out all the crankshaft, holding the crankpins to the horizontal directions.

For D782-E2B, D902-E2B

1. Remove the main bearing case screw 2 (1).
2. Turn the crankshaft to set the crankpin of the third cylinder to the bottom dead center. Then draw out the crankshaft until the crankpin of the second cylinder comes to the center of the third cylinder.
3. Turn the crankshaft by 2.09 rad (120 °) counterclockwise to set the crankpin of the second cylinder to the bottom dead center. Draw out the crankshaft until the crankpin of the first cylinder comes to the center of the third cylinder.
4. Repeat the above steps to draw out all the crankshaft.

(When reassembling)

- Clean the oil passage of the crankshaft with compressed air.
- Install the crankshaft assembly, aligning the screw hole of main bearing case screw 2 with the screw hole of crankcase.
- When tightening the main bearing case 2, apply oil to the main bearing case screw 2 (1) and screw by hand before tightening the specific torque. If not smooth to screw by hand, align the screw holes between the crankcase and the main bearing case.

Tightening torque	Main bearing case screw 2	26.5 to 30.4 N·m 2.7 to 3.1 kgf·m 19.5 to 22.4 ft·lbs

(1) Main Bearing Case Screw 2

[a] Z482-E2B, D602-E2B

[b] D662-E2B, D722-E2B,
D782-E2B, D902-E2B

[c] D782-E2B, D902-E2B

A : Cut place for removing and
installing the crankshaft
(D782-E2B, D902-E2B)

W1031360

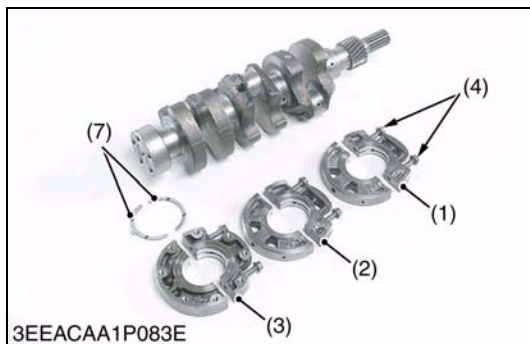
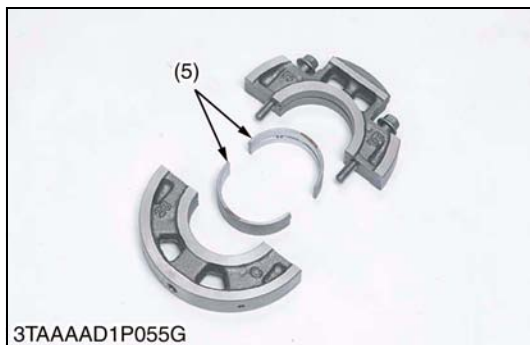
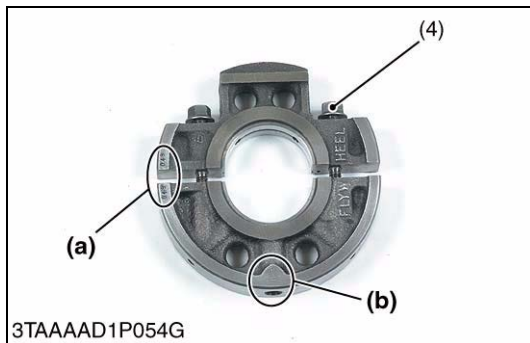
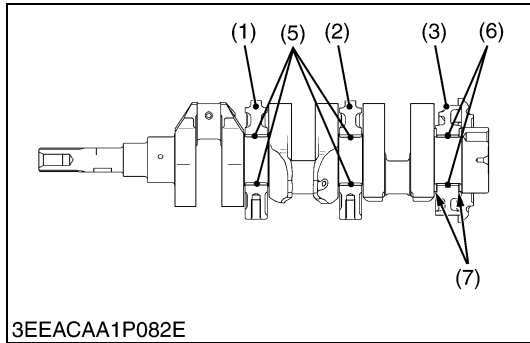
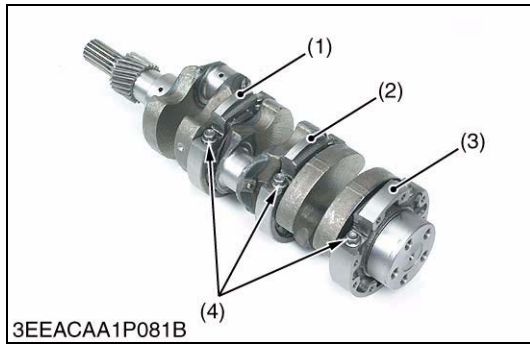

Main Bearing Case Assembly
(Z482-E2B, D662-E2B, D722-E2B, D782-E2B)

1. Remove the two main bearing case screws 1 (4), and remove the main bearing case assembly 1 (1), being careful with crankshaft bearing 3 (5).
2. Remove the main bearing case assembly 2 (2) and the main bearing case assembly (3) as above. Keep in mind, however, that the thrust bearing (7) is installed in the main bearing case assembly (3).

(When reassembling)

- Clean the oil passage in the main bearing cases.
- Apply clean engine oil to the bearings.
- Install the main bearing case assemblies in original positions. Since diameters of main bearing cases vary, install them in order of marking **(b)** (1 for Z482-E2B and 1, 2 for D662-E2B, D722-E2B, D782-E2B) from the gear case side. (Refer to the figure.).
- Match the alignment numbers **(a)** on the main bearing case assembly 1 (1).
- Do the same for the main bearing case assembly 2 (2) and the main bearing case assembly (3) too.
- When installing the main bearing case 1 and 2, face the mark “FLYWHEEL” to the flywheel.
- Install the thrust bearing (7) with its oil groove facing outward.
- Confirm that the main bearing case moves smoothly after tightening the main bearing case screw 1 to the specified torque.

Tightening torque	Main bearing case screw 1	12.7 to 15.7 N·m 1.3 to 1.6 kgf·m 9.4 to 11.6 ft·lbs
-------------------	---------------------------	--

- (1) Main Bearing Case Assembly 1 **(a) Alignment Number**
- (2) Main Bearing Case Assembly 2 **(b) Marking (1 or 2)**
- (3) Main Bearing Case Assembly
- (4) Main Bearing Case Screw 1
- (5) Crankshaft Bearing 3
- (6) Crankshaft Bearing 2
- (7) Thrust Bearing

W1031597

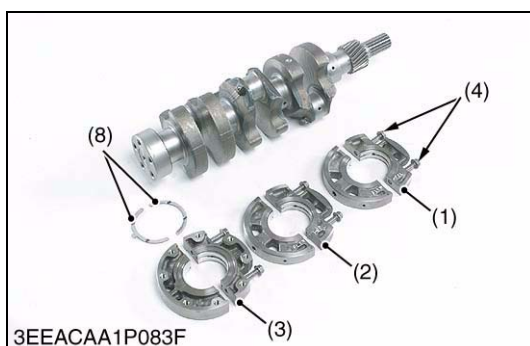
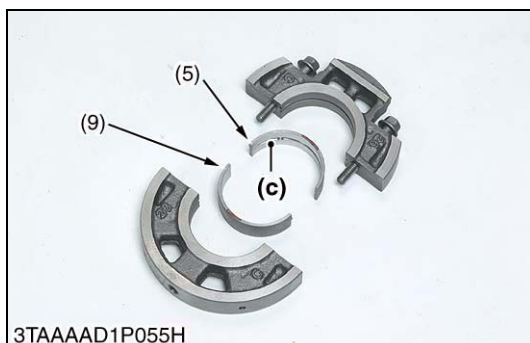
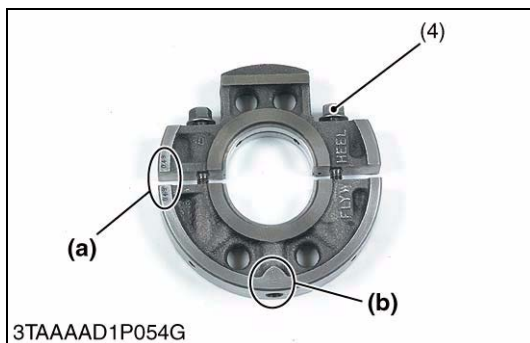
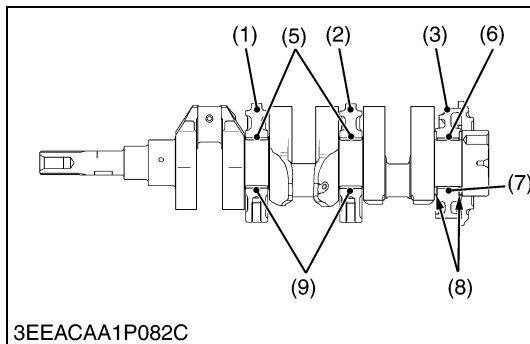
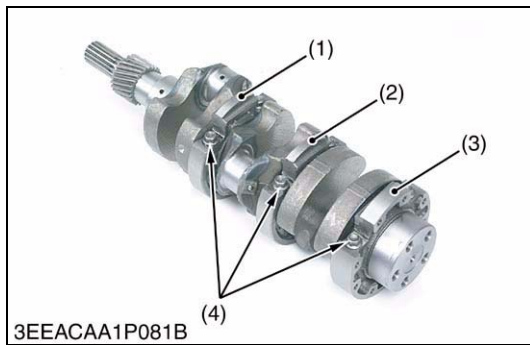

Main Bearing Case Assembly (Z602-E2B, D902-E2B)

1. Remove the two main bearing case screws 1 (4), and remove the main bearing case assembly 1 (1), being careful with crankshaft bearing 3 (5) (9).
2. Remove the main bearing case assembly 2 (2) and the main bearing case assembly (3) as above. Keep in mind, however, that the thrust bearing (8) is installed in the main bearing case assembly (3).

(When reassembling)

- Clean the oil passage in the main bearing cases.
- Apply clean engine oil to the bearings.
- Install the main bearing case assemblies in original positions. Since diameters of main bearing cases vary, install them in order of marking **(b)** (1 for Z602-E2B and 1, 2 for D902-E2B) from the gear case side. (Refer to the figure.).
- Be careful not to confuse the top and bottom of the crankshaft bearing 3 (5) (9). (Install the bearing with the oil groove **(c)** up.)
- Match the alignment numbers **(a)** on the main bearing case assembly 1 (1).
- Do the same for the main bearing case assembly 2 (2) and the main bearing case assembly (3) too.
- When installing the main bearing case 1 and 2, face the mark **“FLYWHEEL”** to the flywheel.
- Install the thrust bearing (8) with its oil groove facing outward.
- Confirm that the main bearing case moves smoothly after tightening the main bearing case screw 1 to the specified torque.

Tightening torque	Main bearing case screw 1	12.7 to 15.7 N·m 1.3 to 1.6 kgf·m 9.4 to 11.6 ft·lbs
-------------------	---------------------------	--

- (1) Main Bearing Case Assembly 1 **(a) Alignment Number**
- (2) Main Bearing Case Assembly 2 **(b) Marking (1 or 2)**
- (3) Main Bearing Case Assembly **(c) Oil Groove**
- (4) Main Bearing Case Screw 1
- (5) Crankshaft Bearing 3
(Upper, with Oil Groove)
- (6) Crankshaft Bearing 2
(Upper, with Oil Groove)
- (7) Crankshaft Bearing 2 (Lower)
- (8) Thrust Bearing
- (9) Crankshaft Bearing 3 (Lower)

W1034602

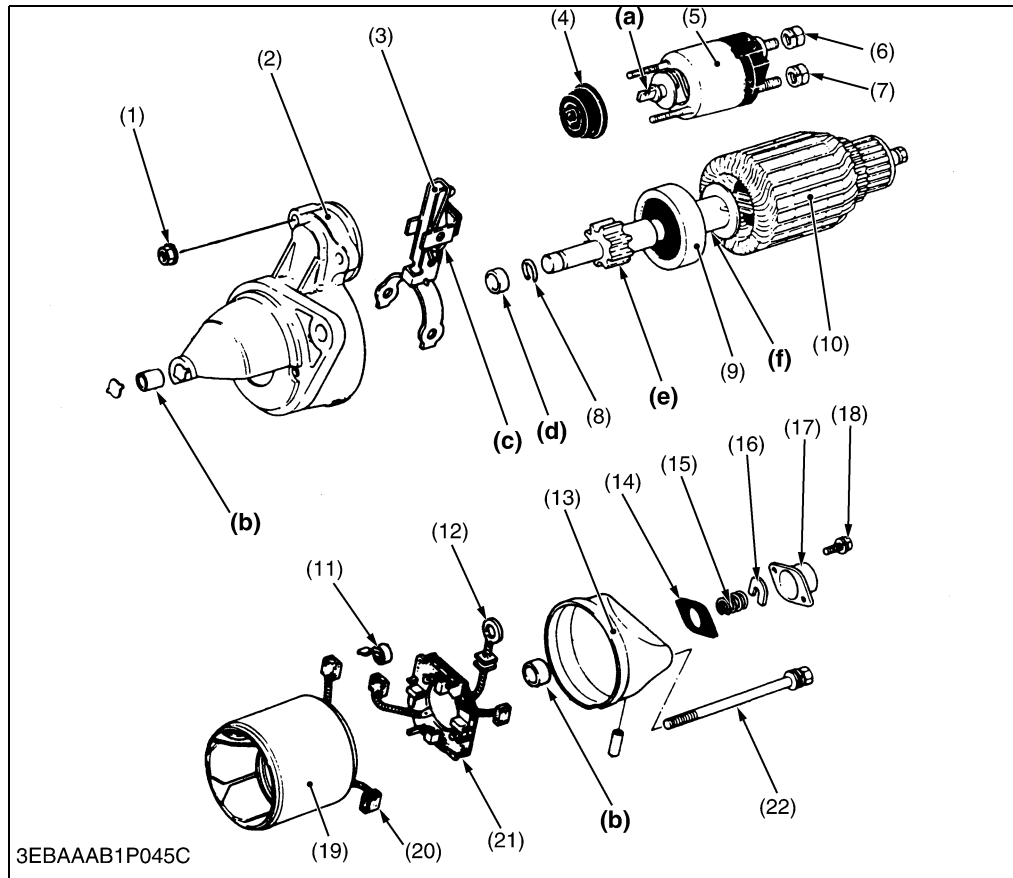
(7) Starter**■ Electromagnetic Drive Type**

- (1) Solenoid Switch Mounting Nut
- (2) Starter Drive Housing
- (3) Drive Lever
- (4) Gasket
- (5) Solenoid Switch
- (6) **B** Terminal Nut
- (7) **C** Terminal Nut
- (8) Snap Ring
- (9) Overrunning Clutch
- (10) Armature
- (11) Brush Spring
- (12) Connecting Lead
- (13) Rear End Frame
- (14) Gasket
- (15) Brake Spring
- (16) Brake Shoe
- (17) End Frame Cap
- (18) Screw
- (19) Yoke
- (20) Brush
- (21) Brush Holder
- (22) Through Bolt

W1037593

1. Unscrew the **C** terminal nut (7), and disconnect the connecting lead (12).
2. Unscrew the solenoid switch mounting nuts (1), and remove the solenoid switch (5).
3. Remove the end frame cap (17).
4. Remove the brake shoe (16), brake spring (15) and gasket (14).
5. Unscrew the through bolts (22), and remove the rear end frame (13).
6. Remove the brush from the brush holder while holding the spring up.
7. Remove the brush holder (21).
8. Draw out the yoke (19) from the starter drive housing (2).
9. Draw out the armature (10) with the drive lever (3).

■ NOTE

- **Do not damage to the brush and commutator.**

(When reassembling)

- Apply grease (DENSO.CO.LTD. No. 50 or equivalent) to the parts indicated in the figure.
 - Joint of solenoid switch **(a)**
 - Bushing **(b)**
 - Drive lever **(c)**
 - Collar **(d)**
 - Teeth of pinion gear **(e)**
 - Armature shaft **(f)**

Tightening torque	B terminal nut	7.8 to 9.8 N·m 0.8 to 1.0 kgf·m 5.8 to 7.2 ft·lbs
-------------------	-----------------------	---

W1012736

■ Planetary Gear Reduction Type

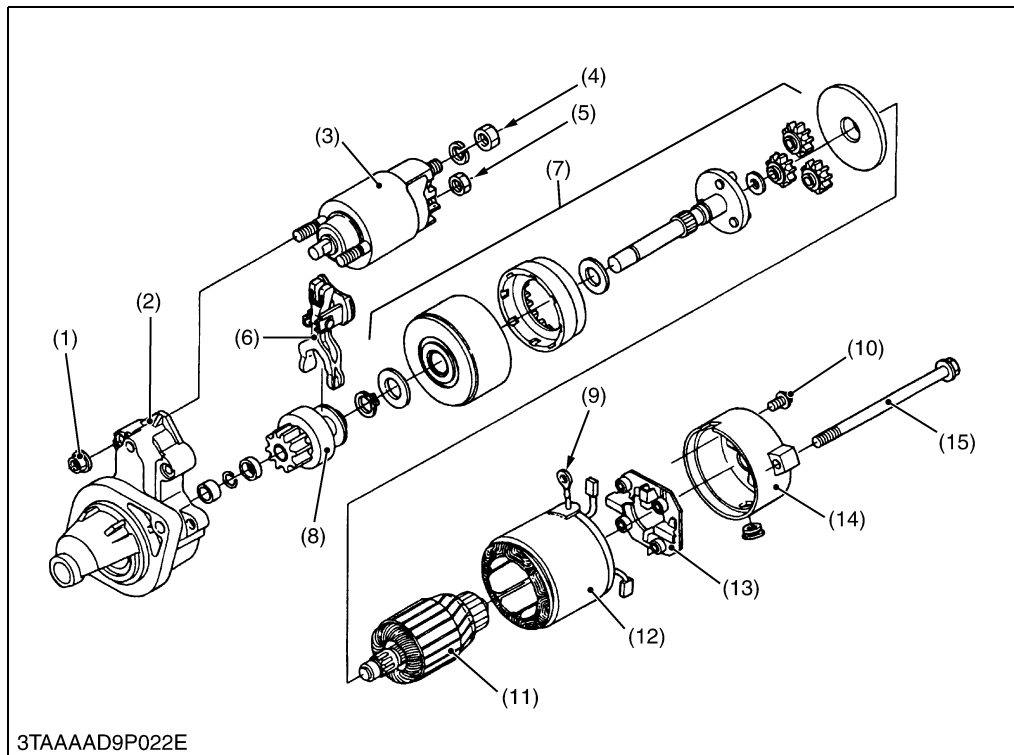

- (1) Magnetic Switch Mounting Nut
- (2) Housing
- (3) Magnetic Switch
- (4) **B** Terminal Nut
- (5) **C** Terminal Nut
- (6) Drive Lever
- (7) Shaft Assembly
- (8) Overrunning Clutch
- (9) Connecting Lead
- (10) Mounting Screw
- (11) Armature
- (12) Yoke
- (13) Brush Holder
- (14) Rear End Frame
- (15) Through Bolt

W1222714

3TAAAD9P022E

1. Unscrew the **C** terminal nut (5), and disconnect the connecting lead (9).
2. Unscrew the magnetic switch mounting nuts (1), and remove the magnetic switch (3) from the housing (2).
3. Unscrew the through bolts (15) and mounting screw (10), and remove the rear end frame (14).
4. Remove the brush from the brush holder while holding the spring up.
5. Remove the brush holder (13).
6. Draw out the armature (11) and yoke (12) from the housing.
7. Draw out the shaft assembly (7) with the drive lever (6) and overrunning clutch (8) from the housing.

(When reassembling)

Tightening torque	B terminal nut	5.9 to 11.8 N·m 0.6 to 1.2 kgf·m 4.3 to 8.7 ft·lbs
-------------------	-----------------------	--

W1012736

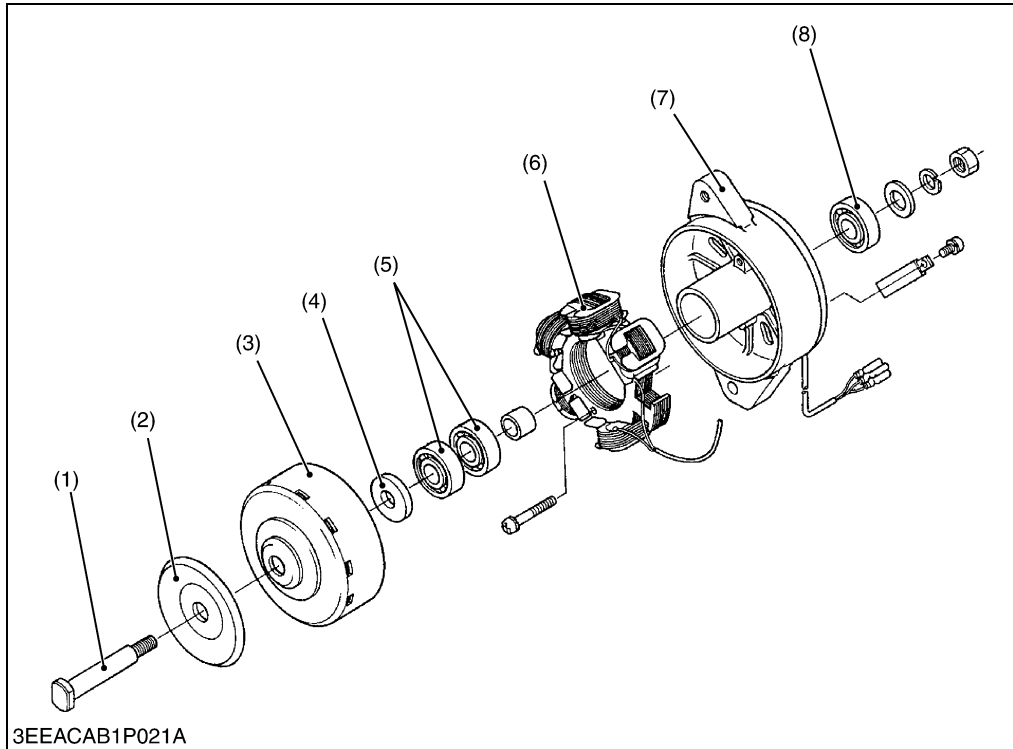
(8) Dynamo

- (1) Shaft
- (2) Pulley
- (3) Rotor
- (4) Collar
- (5) Bearing
- (6) Stator
- (7) Plate
- (8) Bearing

W1036558

3EEACAB1P021A

1. Remove the nut and separate the plate (7).
2. Tap out the shaft (1) from the rotor (3).
3. Unscrew the screws and remove the stator (6).

(When reassembling)

- Take care the direction of the collar (4), the flat side should face to the pulley side

Tightening torque	Pulley nut	39.2 to 44.1 N·m 4.0 to 4.5 kgf·m 28.9 to 32.5 ft-lbs
-------------------	------------	---

W1224556

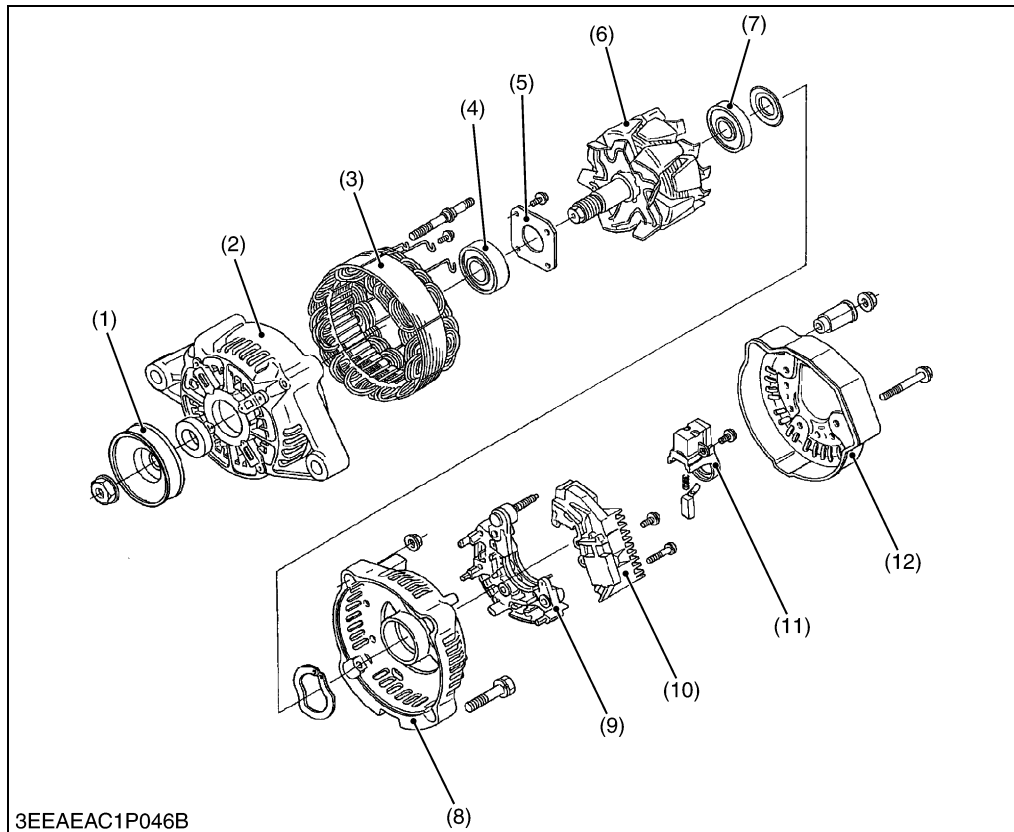
(9) Alternator

- (1) Pulley
- (2) Drive End Frame
- (3) Stator
- (4) Bearing
- (5) Retainer Plate
- (6) Rotor
- (7) Bearing
- (8) Rear End Frame
- (9) Rectifier
- (10) IC Regulator
- (11) Brush Holder
- (12) Rear End Cover

W1224079

1. Remove the pulley (1).
2. Remove the rear end cover (12).
3. Remove the brush holder (11).
4. Remove the IC regulator (10).
5. Remove the four screws holding the stator lead wires.
6. Remove the rectifier (9).
7. Remove the rear end frame (8).
8. Press out the rotor (6) from drive end frame (2).
9. Remove the retainer plate (5).
10. Press out the bearing (4) from drive end frame (2) with a press and jig.
11. Lightly secure the rotor with a vise to prevent damage, and remove the bearing (7) with a puller.

(When reassembling)

Tightening torque	Pulley nut	58.3 to 78.9 N-m 5.95 to 8.05 kgf-m 43.0 to 58.2 ft-lbs
-------------------	------------	---

W1224556

[3] SERVICING

(1) Cylinder Head and Valves

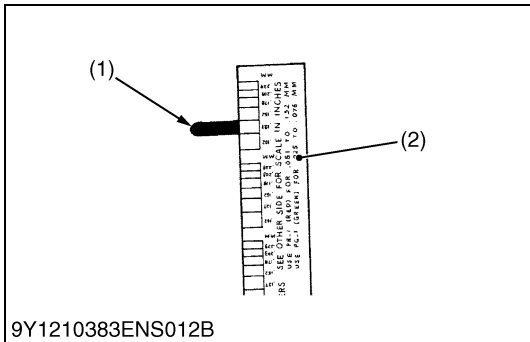
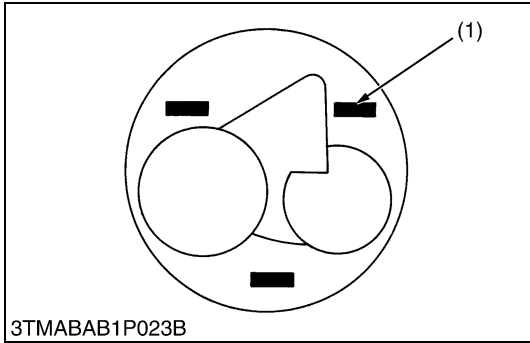

Top Clearance

1. Remove the cylinder head.
2. With the piston at TDC, use grease to affix three or four plastigauges of a diameter 1.5 mm (0.059 in.) x 5.0 to 7.0 mm (0.20 to 0.27 in.) long to the crown of the piston; keep the gauges away from the intake valve and combustion chamber fittings.
3. Take the piston to an intermediate position, install the cylinder head and tighten the head bolts to the specified torque.
4. Turn the crankshaft so the piston goes through TDC.
5. Remove the cylinder head and compare the width of the crushed plastigages with the scale.
6. If they are out of spec, check the oil clearance of the crank pin, journals and piston pin.

NOTE

- Top clearance = Width of the crushed plastigauge.

Top clearance	Factory spec.	0.50 to 0.70 mm 0.0197 to 0.0276 in.
Tightening torque	Cylinder head mounting screw	37.3 to 42.2 N·m 3.8 to 4.3 kgf·m 27.5 to 31.1 ft-lbs

(1) Plastigauge

(2) Scale

W1020190



Cylinder Head Surface Flatness

1. Clean the cylinder head surface.
2. Place a straightedge on the cylinder head's four sides and two diagonal as shown in the figure.
3. Measure the clearance with a thickness gauge.
4. If the measurement exceeds the allowable limit, correct it with a surface grinder.

IMPORTANT

- Do not place the straightedge on the combustion chamber.
- Be sure to check the valve recessing after correcting.

Cylinder head surface flatness	Allowable limit	0.05 mm 0.0020 in.
--------------------------------	-----------------	-----------------------

W1027737

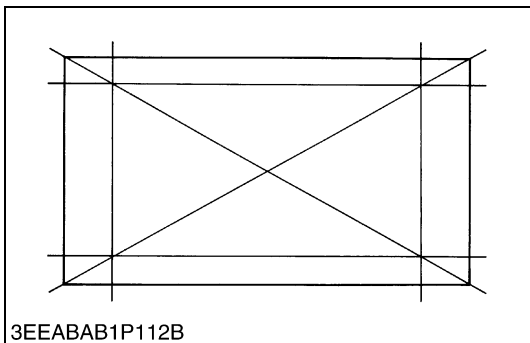

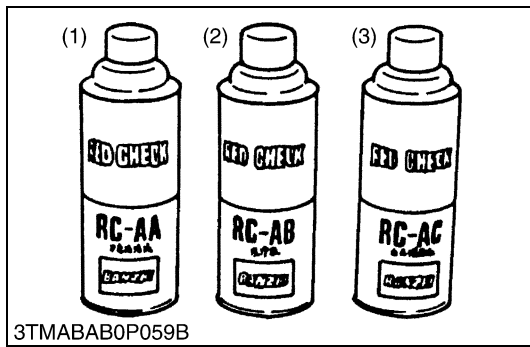

Cylinder Head Flaw

1. Prepare an air spray red check.
2. Clean the surface of the cylinder head with detergent (2).
3. Spray the cylinder head surface with the red permeative liquid (1). Leave it five to ten minutes after spraying.
4. Wash away the red permeative liquid on the cylinder head surface with the detergent (2).
5. Spray the cylinder head surface with white developer (3).
6. If flawed, it can be identified as red marks.

- (1) Red Permeative Liquid (3) White Developer
 (2) Detergent

W1076542



Valve Recessing

1. Clean the cylinder head surface, valve face and valve seat.
2. Insert the valve into the valve guide.
3. Measure the valve recessing with a depth gauge.
4. If the measurement exceeds the allowable limit, replace the valve.
5. If it still exceeds the allowable limit after replacing the valve, replace the cylinder head.

Valve recessing (Intake and exhaust)	Factory spec.	0.10 (protrusion) to 0.10 (recessing) mm 0.0039 (protrusion) to 0.0039 (recessing) in.
	Allowable limit	0.30 (recessing) mm 0.0118 (recessing) in.

- (1) Cylinder Head Surface (A) Recessing
 (B) Protrusion

W10768800

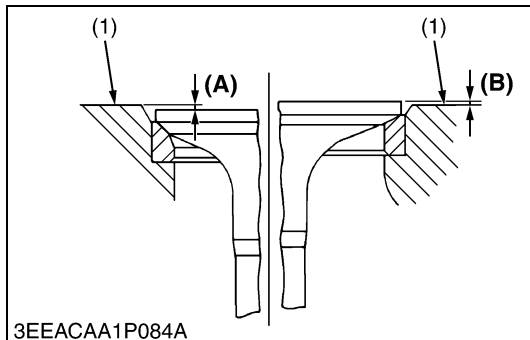

Clearance between Valve Stem and Valve Guide

1. Remove carbon from the valve guide section.
2. Measure the valve stem O.D. with an outside micrometer.
3. Measure the valve guide I.D. with a small hole gauge, and calculate the clearance.
4. If the clearance exceeds the allowable limit, replace the valves. If it still exceeds the allowable limit, replace the valve guide.

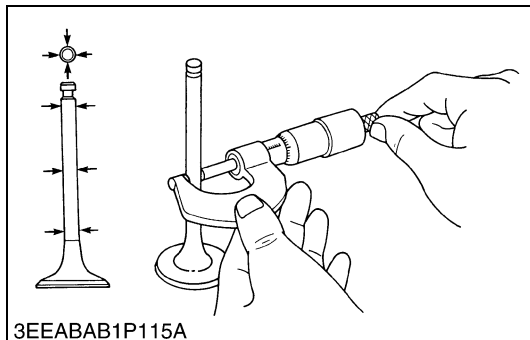

Clearance between valve stem and valve guide	Factory spec.	0.030 to 0.057 mm 0.00118 to 0.00224 in.
	Allowable limit	0.10 mm 0.0039 in.

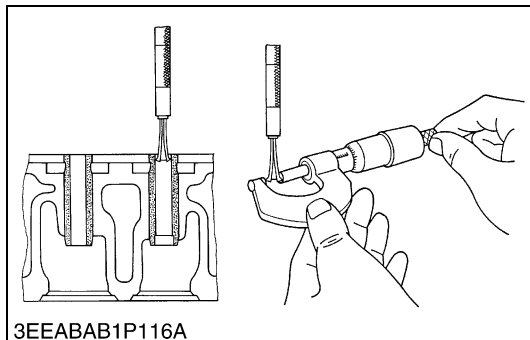

Valve stem O.D.	Factory spec.	5.968 to 5.980 mm 0.23496 to 0.23543 in.
Valve guide I.D.	Factory spec.	6.010 to 6.025 mm 0.23661 to 0.23720 in.

W10311740

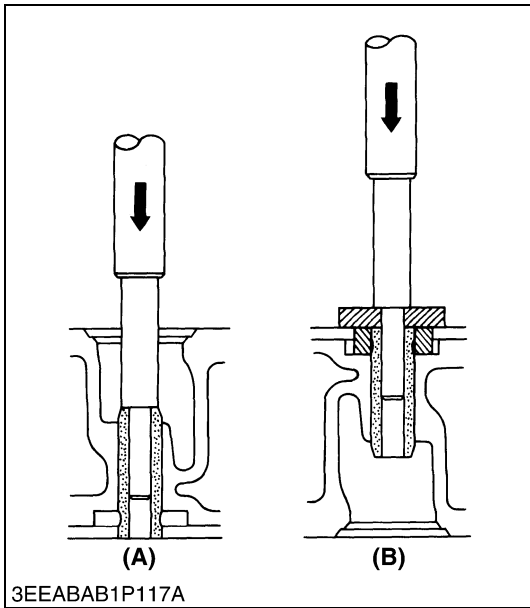

Replacing Valve Guide

(When removing)

1. Press out the used valve guide using a valve guide replacing tool. (Refer to "SPECIAL TOOLS".)

(When installing)

1. Clean a new valve guide and valve guide bore, and apply engine oil to them.
2. Press in a new valve guide using a valve guide replacing tool.
3. Ream precisely the I.D. of the valve guide to the specified dimension.

Valve guide I.D. (Intake and exhaust)	Factory spec.	6.010 to 6.025 mm 0.23661 to 0.23720 in.
--	---------------	---

■ IMPORTANT

- Do not hit the valve guide with a hammer during replacement.

(A) When Removing

(B) When Installing

W10314690

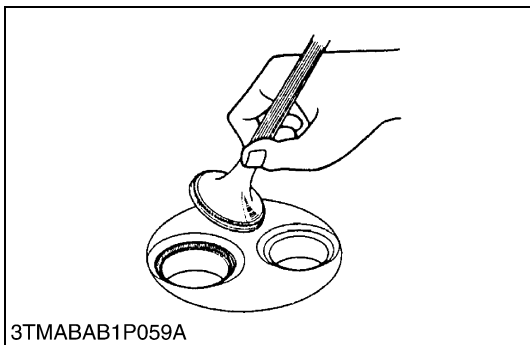

Valve Seating

1. Coat the valve face lightly with prussian blue and put the valve on its seat to check the contact.
2. If the valve does not seat all the way around the valve seat or the valve contact is less than 70 %, correct the valve seating as follows.
3. If the valve contact does not comply with the reference value, replace the valve or correct the contact of valve seating.

Valve seat width	Factory spec.	2.12 mm 0.0835 in.
------------------	---------------	-----------------------

- (1) Correct
(2) Incorrect

(3) Incorrect

W10282190

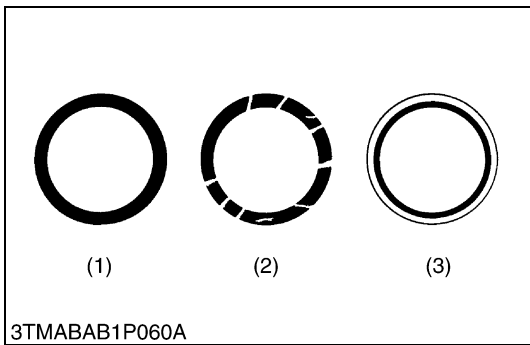

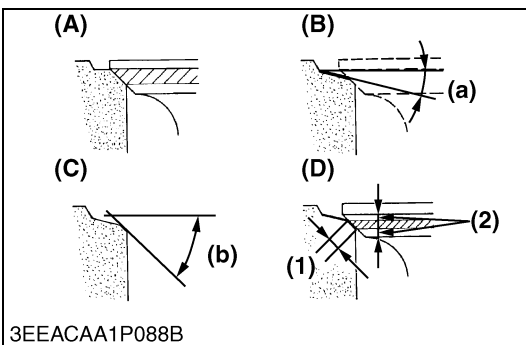
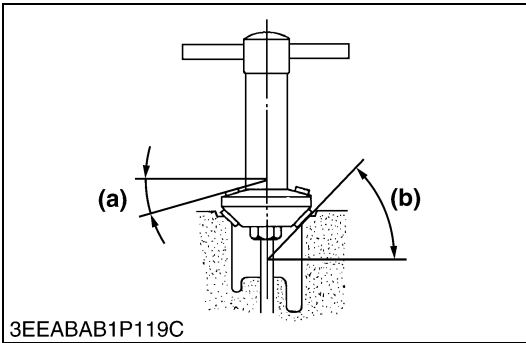
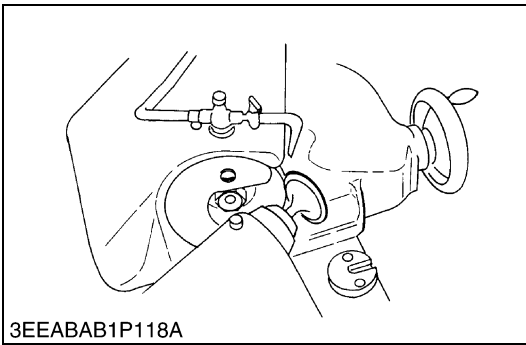

Correcting Valve and Valve Seat

NOTE

- Before correcting the valve and seat, check the valve stem and the I.D. of valve guide section, and repair them if necessary.
- After correcting the valve seat, be sure to check the valve recessing.

1) Correcting Valve

1. Correct the valve with a valve refacer.

Valve face angle	Factory spec.	0.785 rad 45 °
------------------	---------------	-------------------

2) Correcting Valve Seat

1. Slightly correct the seat surface with a 0.785 rad (45 °) valve seat cutter.
2. Fitting the valve, check the contact position of the valve face and seat surface with prussian blue. (Visual check) [If the valve has been used for a long period, the seat tends to come in contact with the upper side of the valve face.]
3. Grind the upper surface of the seat with a 0.262 rad (15 °) valve seat cutter until the valve seat touches to the center of the valve face (so that (1) equals (2) as shown in the figure.)
4. Grind the seat with a 0.785 rad (45 °) valve seat cutter again, and visually recheck the contact between the valve and seat.
5. Repeat steps 3 and 4 until the correct contact is achieved.
6. Continue lapping until the seated rate becomes more than 70 % of the total contact area.

Valve seat angle	Factory spec.	0.785 rad 45 °
------------------	---------------	-------------------

- (1) Valve Seat Width (a) 0.262 rad (15 °)
 (2) Identical Dimensions (b) 0.785 rad (45 °)

- (A) Check Contact
 (B) Correct Seat Width
 (C) Check Seat Surface
 (D) Check Contact

W10283500

Valve Lapping

1. Apply compound evenly to the valve lapping surface.
2. Insert the valve into the valve guide. Lap the valve onto its seat with a valve flapper or screwdriver.
3. After lapping the valve, wash the compound away and apply oil, then repeat valve lapping with oil.
4. Apply prussian blue to the contact surface to check the seated rate. If it is less than 70 %, repeat valve lapping again.

IMPORTANT

- When valve lapping is performed, be sure to check the valve recessing and adjust the valve clearance after assembling the valve.

W10288140

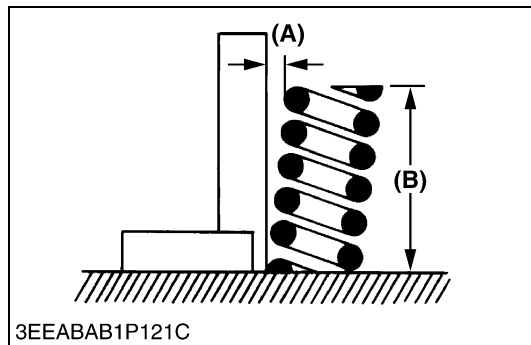

Free Length and Tilt of Valve Spring

1. Measure the free length **(B)** of valve spring with vernier calipers. If the measurement is less than the allowable limit, replace it.
2. Put the valve spring on a surface plate, place a square on the side of the valve spring.
3. Check to see if the entire side is in contact with the square. Rotate the valve spring and measure the maximum tilt **(A)**. If the measurement exceeds the allowable limit, replace it.
4. Check the entire surface of the valve spring for scratches. If there is any defect, replace it.

Tilt (A)	Allowable limit	1.2 mm 0.047 in.
-----------------	-----------------	---------------------

Free length (B)	Factory spec.	31.3 to 31.8 mm 1.232 to 1.252 in.
	Allowable limit	28.4 mm 1.118 in.

(A) Tilt**(B) Free Length**

W11157830

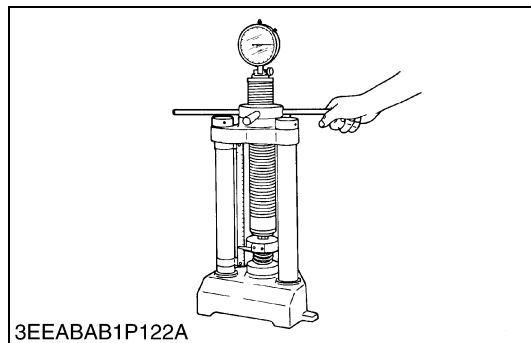

Valve Spring Setting Load

1. Place the valve spring on a tester and compress it to the same length it is actually compressed the engine.
2. Read the compression load on the gauge.
3. If the measurement is less than the allowable limit, replace it.

Setting load / Setting length	Factory spec.	64.7 N / 27.0 mm 6.6 kgf / 27.0 mm 14.6 lbs / 1.063 in.
	Allowable limit	54.9 N / 27.0 mm 5.6 kgf / 27.0 mm 12.3 lbs / 1.063 in.

W11177330



Oil Clearance between Rocker Arm and Rocker Arm Shaft

1. Measure the rocker arm shaft O.D. with an outside micrometer.
2. Measure the rocker arm I.D. with an inside micrometer, and then calculate the oil clearance.
3. If the oil clearance exceeds the allowable limit, replace the rocker arm and measure the oil clearance again. If it still exceeds the allowable limit, replace also the rocker arm shaft.

Oil clearance between rocker arm and rocker arm shaft	Factory spec.	0.016 to 0.045 mm 0.00063 to 0.00177 in.
	Allowable limit	0.15 mm 0.0059 in.

Rocker arm shaft O.D.	Factory spec.	10.473 to 10.484 mm 0.41232 to 0.41276 in.
Rocker arm I.D.	Factory spec.	10.500 to 10.518 mm 0.41339 to 0.41410 in.

W11199710

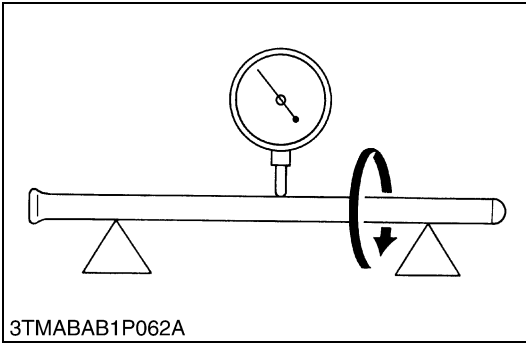

Push Rod Alignment

1. Place the push rod on V blocks.
2. Measure the push rod alignment.
3. If the measurement exceeds the allowable limit, replace the push rod.

Push rod alignment	Allowable limit	0.25 mm 0.0098 in.
--------------------	-----------------	-----------------------

W11220210



Oil Clearance between Tappet and Tappet Guide Bore

1. Measure the tappet O.D. with an outside micrometer.
2. Measure the I.D. of the tappet guide bore with a cylinder gauge, and calculate the oil clearance.
3. If the oil clearance exceeds the allowable limit or the tappet is damaged, replace the tappet.

Oil clearance between tappet and tappet guide bore	Factory spec.	0.016 to 0.052 mm 0.00063 to 0.00205 in.
	Allowable limit	0.10 mm 0.0039 in.



Tappet O.D.	Factory spec.	17.966 to 17.984 mm 0.70732 to 0.70803 in.
Tappet guide bore I.D.	Factory spec.	18.000 to 18.018 mm 0.70866 to 0.70937 in.

W11231410

(2) Timing Gears

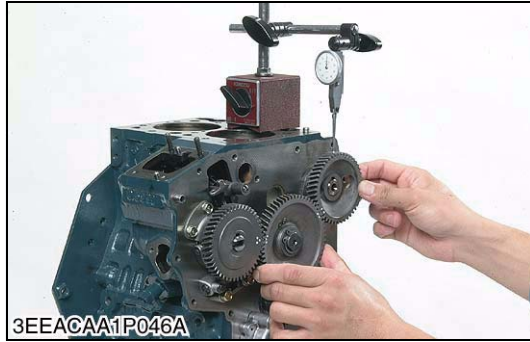

Timing Gear Backlash

1. Set a dial indicator (lever type) with its tip on the gear tooth.
2. Move the gear to measure the backlash, holding its mating gear.
3. If the backlash exceeds the allowable limit, check the oil clearance of the shaft and the gear.
4. If the oil clearance is proper, replace the gear.

Backlash between idle gear and crank gear	Factory spec.	0.043 to 0.124 mm 0.00169 to 0.00488 in.
	Allowable limit	0.15 mm 0.0059 in.

Backlash between idle gear and cam gear	Factory spec.	0.047 to 0.123 mm 0.00185 to 0.00484 in.
	Allowable limit	0.15 mm 0.0059 in.

Backlash between idle gear and injection pump gear	Factory spec.	0.046 to 0.124 mm 0.00181 to 0.00488 in.
	Allowable limit	0.15 mm 0.0059 in.

Backlash between oil pump drive gear and crank gear	Factory spec.	0.041 to 0.123 mm 0.00161 to 0.00484 in.
	Allowable limit	0.15 mm 0.0059 in.

W11264830



Idle Gear Side Clearance

1. Set a dial indicator with its tip on the idle gear.
2. Measure the side clearance by moving the idle gear to the front and rear.
3. If the measurement exceeds the allowable limit, replace the idle gear collar.

Idle gear side clearance	Factory spec.	0.20 to 0.51 mm 0.0079 to 0.0201 in.
	Allowable limit	0.80 mm 0.0315 in.

W11286770



Camshaft Side Clearance

1. Set a dial indicator with its tip on the camshaft.
2. Measure the side clearance by moving the cam gear to the front and rear.
3. If the measurement exceeds the allowable limit, replace the camshaft stopper.

Camshaft side clearance	Factory spec.	0.15 to 0.31 mm 0.0059 to 0.0122 in.
	Allowable limit	0.50 mm 0.0197 in.

W11299720

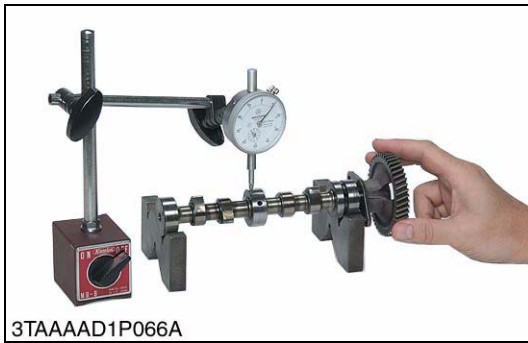

3TAAAD1P066A

Camshaft Alignment

1. Support the camshaft with V blocks on the surface plate at both end journals.
2. Set a dial indicator with its tip on the intermediate journal.
3. Measure the camshaft alignment.
4. If the measurement exceeds the allowable limit, replace the camshaft.

Camshaft alignment	Allowable limit	0.01 mm 0.0004 in.
--------------------	-----------------	-----------------------

W11312720

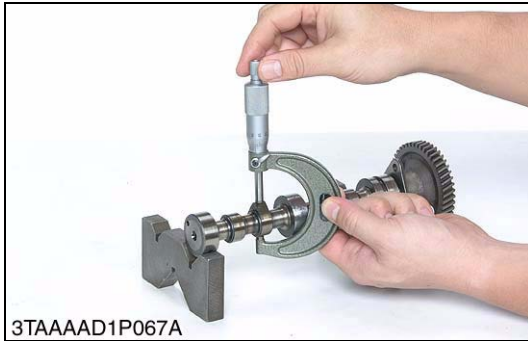

3TAAAD1P067A

Cam Height

1. Measure the height of the cam at its highest point with an outside micrometer.
2. If the measurement is less than the allowable limit, replace the camshaft.

Cam height of intake and exhaust	Factory spec.	26.88 mm 1.0583 in.
	Allowable limit	26.83 mm 1.0563 in.

W11324040



3TAAAD1P069A

Oil Clearance of Camshaft Journal

1. Measure the camshaft journal O.D. with an outside micrometer.
2. Measure the cylinder block bore I.D. for camshaft with a inside micrometer, and calculate the oil clearance.
3. If the oil clearance exceeds the allowable limit, replace the camshaft.

Oil clearance of camshaft journal	Factory spec.	0.050 to 0.091 mm 0.00197 to 0.00358 in.
	Allowable limit	0.15 mm 0.0059 in.



3EEACAA1P049A

Camshaft journal O.D.	Factory spec.	32.934 to 32.950 mm 1.29661 to 1.29724 in.
Camshaft Bearing I.D. (Cylinder block bore I.D.)	Factory spec.	33.000 to 33.025 mm 1.29921 to 1.30020 in.

W11335580

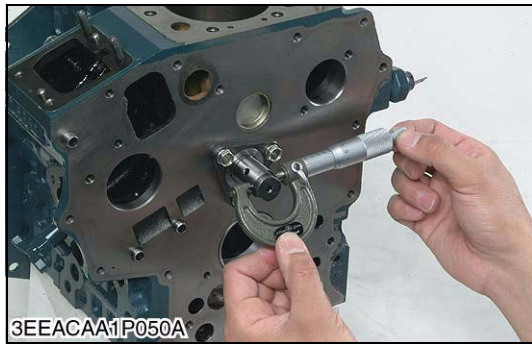

3EEACAA1P050A



3TAAAD1P071A

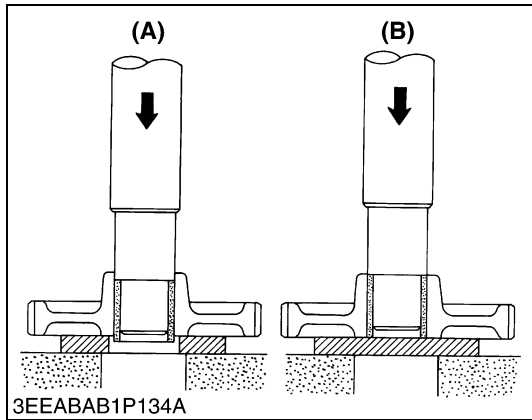

3EEABAB1P134A

(3) Piston and Connecting Rod

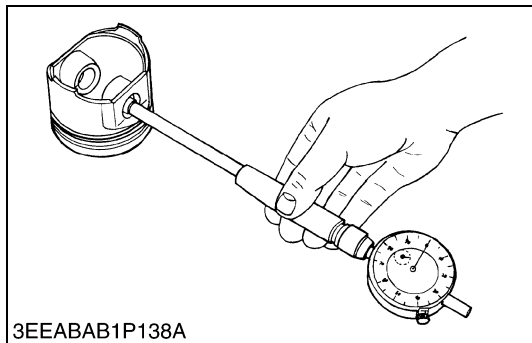

3EEABAB1P138A

Oil Clearance between Idle Gear Shaft and Idle Gear Bushing

1. Measure the idle gear shaft O.D. with an outside micrometer.
2. Measure the idle gear bushing I.D. with an inside micrometer, and calculate the oil clearance.
3. If the oil clearance exceeds the allowable limit, replace the bushing.
4. If it still exceeds the allowable limit, replace the idle gear shaft.

Oil clearance between idle gear shaft and idle gear bushing	Factory spec.	0.020 to 0.084 mm 0.00079 to 0.00331 in.
	Allowable limit	0.10 mm 0.0039 in.

Idle gear shaft O.D.	Factory spec.	19.967 to 19.980 mm 0.78610 to 0.78661 in.
Idle gear bushing I.D.	Factory spec.	20.000 to 20.051 mm 0.78740 to 0.78941 in.

W11356150

Replacing Idle Gear Bushing

(When removing)

1. Press out the used idle gear bushing using an idle gear bushing replacing tool. (Refer to "SPECIAL TOOLS".)

(When installing)

1. Clean a new idle gear bushing and idle gear bore, and apply engine oil to them.
2. Press in a new bushing using an idle gear bushing replacing tool, until it is flush with the end of the idle gear.

(A) When Removing

(B) When Installing

W11373220

Piston Pin Bore I.D.

1. Measure the piston pin bore I.D. in both the horizontal and vertical directions with a cylinder gauge.
2. If the measurement exceeds the allowable limit, replace the piston.

Piston pin bore I.D.	Factory spec.	20.000 to 20.013 mm 0.78740 to 0.78791 in.
	Allowable limit	20.05 mm 0.7894 in.

W11406200

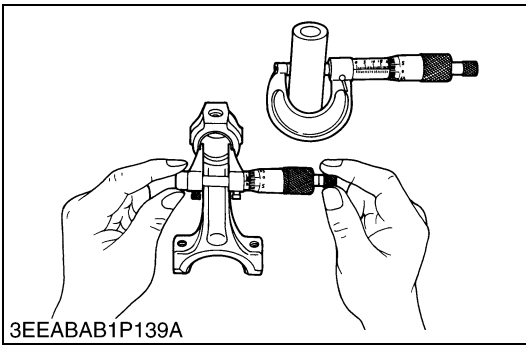

3EEABAB1P139A

Oil Clearance between Piston Pin and Small End Bushing

1. Measure the piston pin O.D. where it contacts the bushing with an outside micrometer.
2. Measure the small end bushing I.D. with an inside micrometer, and calculate the oil clearance.
3. If the oil clearance exceeds the allowable limit, replace the bushing. If it still exceeds the allowable limit, replace the piston pin.

Oil clearance between piston pin and small end bushing	Factory spec.	0.014 to 0.038 mm 0.00055 to 0.00150 in.
	Allowable limit	0.10 mm 0.0039 in.

Piston pin O.D.	Factory spec.	20.002 to 20.011 mm 0.78748 to 0.78783 in.
Small end bushing I.D.	Factory spec.	20.025 to 20.040 mm 0.78839 to 0.78897 in.

W11420110

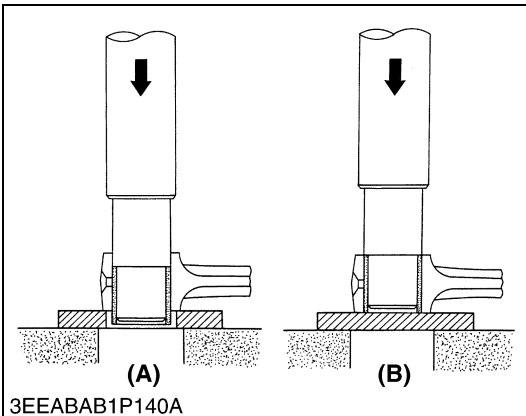

3EEABAB1P140A

Replacing Small End Bushing

(When removing)

1. Press out the used bushing using a small end bushing replacing tool. (Refer to "SPECIAL TOOLS")

(When installing)

1. Clean a new small end bushing and small end hole, and apply engine oil to them.
2. Using a small end bushing replacing tool, press in a new bushing (service parts) taking due care to see that the position of the connecting rod oil hole matches the bushing hole.

[Servicing parts dimension]

Oil clearance between piston pin and small end bushing (Spare parts)	Factory spec.	0.015 to 0.075 mm 0.00059 to 0.00295 in.
	Allowable limit	0.15 mm 0.0059 in.

Small end bushing I.D. (Spare parts)	Factory spec.	20.026 to 20.077 mm 0.78843 to 0.79043 in.
--------------------------------------	---------------	---

- (1) Seam
(2) Oil Hole

- (A) When Removing
(B) When Installing
(a) 0.785 rad (45°)

W11437590

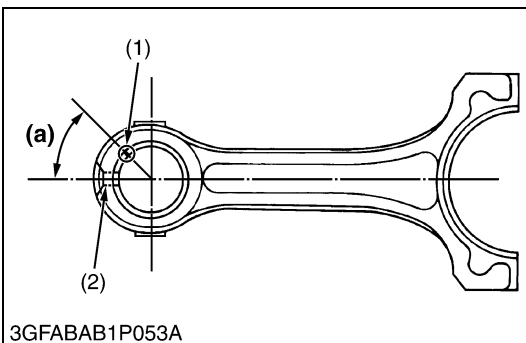

3GFABAB1P053A

Connecting Rod Alignment

NOTE

- Since the I.D. of the connecting rod small end bushing is the basis of this check, check bushing for wear beforehand.

1. Install the piston pin into the connecting rod.
2. Install the connecting rod on the connecting rod alignment tool.
3. Put a gauge over the piston pin, and move it against the face plate.
4. If the gauge does not fit squarely against the face plate, measure the space between the pin of the gauge and the face plate.
5. If the measurement exceeds the allowable limit, replace the connecting rod.

Connecting rod alignment	Allowable limit	0.05 mm 0.0020 in.
--------------------------	-----------------	-----------------------

W10314620

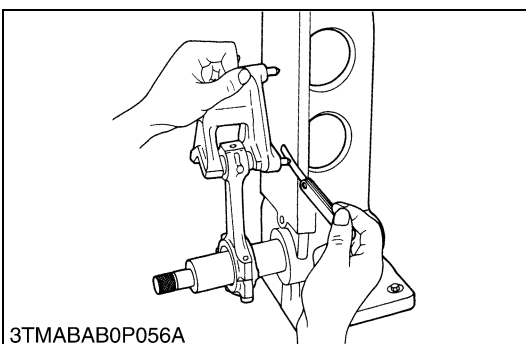

3TMABAB0P056A

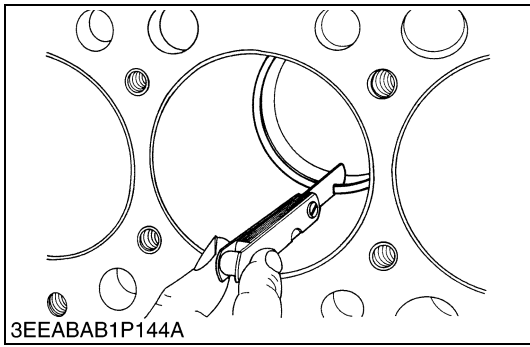

Piston Ring Gap

1. Insert the piston ring into the lower part of the cylinder (the least worn out part) with a piston ring compressor and piston.
2. Measure the ring gap with a feeler gauge.
3. If the measurement exceeds the allowable limit, replace the piston ring.

Piston ring gap [Z482-E2B] [D662-E2B] [D722-E2B] [D782-E2B]	Top ring	Factory spec.	0.15 to 0.30 mm 0.0059 to 0.0118 in.
		Allowable limit	1.20 mm 0.0472 in.
	Second ring	Factory spec.	0.30 to 0.45 mm 0.0118 to 0.0177 in.
		Allowable limit	1.20 mm 0.0472 in.
	Oil ring	Factory spec.	0.15 to 0.30 mm 0.0059 to 0.0118 in.
		Allowable limit	1.20 mm 0.0472 in.
Piston ring gap [Z602-E2B] [D902-E2B]	Top ring	Factory spec.	0.20 to 0.35 mm 0.0079 to 0.0138 in.
		Allowable limit	1.25 mm 0.0492 in.
	Second ring	Factory spec.	0.35 to 0.50 mm 0.0138 to 0.0197 in.
		Allowable limit	1.25 mm 0.0492 in.
	Oil ring	Factory spec.	0.20 to 0.35 mm 0.0079 to 0.0138 in.
		Allowable limit	1.25 mm 0.0492 in.

W11466710

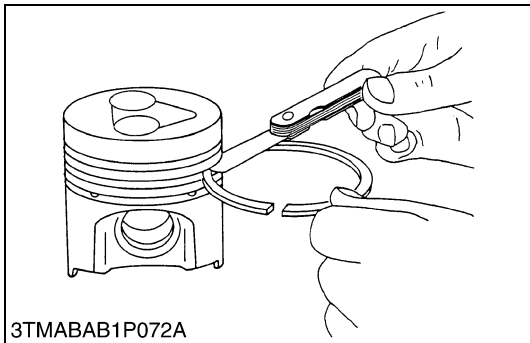

Clearance between Piston Ring and Piston Ring Groove

1. Clean the rings and the ring grooves, and install each ring in its groove.
2. Measure the clearance between the ring and the groove with a feeler gauge.
3. If the clearance exceeds the allowable limit, replace the piston ring.
4. If the clearance still exceeds the allowable limit after replacing the ring, replace the piston.

Clearance between piston ring and piston ring groove	Second ring	Factory spec.	0.090 to 0.120 mm 0.00354 to 0.00472 in.
		Allowable limit	0.15 mm 0.0059 in.
	Oil ring	Factory spec.	0.04 to 0.08 mm 0.0016 to 0.0031 in.
		Allowable limit	0.15 mm 0.0059 in.

W11485500

(4) Crankshaft

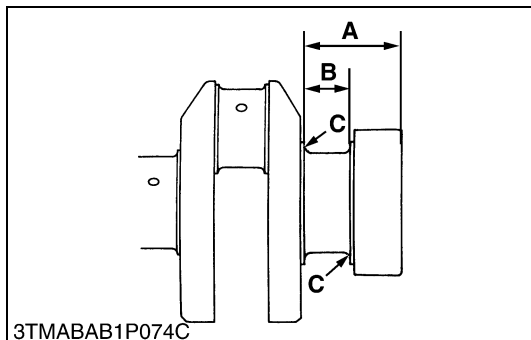
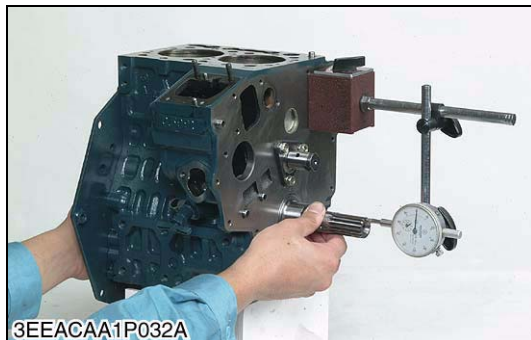

Crankshaft Side Clearance

1. Set a dial indicator with its tip on the end of the crankshaft.
2. Measure the side clearance by moving the crankshaft to the front and rear.
3. If the measurement exceeds the allowable limit, replace the thrust bearings.
4. If the same size bearing is useless because of the crankshaft journal wear, replace it with an oversize one referring to the table and figure.

Crankshaft side clearance	Factory spec.	0.15 to 0.31 mm 0.0059 to 0.0122 in.
	Allowable limit	0.50 mm 0.0197 in.

(Reference)

- Oversize thrust bearing

Oversize	Bearing	Code Number	Marking
0.2 mm 0.008 in.	Thrust bearing 1 02	15261-23950	020 OS
	Thrust bearing 2 02	15261-23970	020 OS
0.4 mm 0.016 in.	Thrust bearing 1 04	15261-23960	040 OS
	Thrust bearing 2 04	15261-23980	040 OS

- Oversize dimensions of crankshaft journal

Oversize	0.2 mm 0.008 in.	0.4 mm 0.016 in.
Dimension A	46.1 to 46.3 mm 1.815 to 1.823 in.	46.3 to 46.5 mm 1.823 to 1.831 in.
Dimension B	23.40 to 23.45 mm 0.9213 to 0.9232 in.	23.80 to 23.85 mm 0.9370 to 0.9390 in.
Dimension C	1.8 to 2.2 mm radius 0.071 to 0.087 in. radius	1.8 to 2.2 mm radius 0.071 to 0.087 in. radius
(0.8S)		
The crankshaft journal must be fine-finished to higher than ∇∇∇∇.		

W11586190



Crankshaft Alignment

1. Support the crankshaft with V blocks on the surface plate at both end journals.
2. Set a dial indicator with its tip on the intermediate journal.
3. Measure the crankshaft alignment.
4. If the measurement exceeds the allowable limit, replace the crankshaft.

Crankshaft alignment	Allowable limit	0.02 mm 0.0008 in.
----------------------	-----------------	-----------------------

W11613530

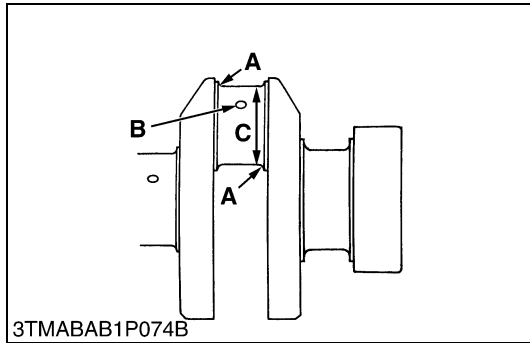
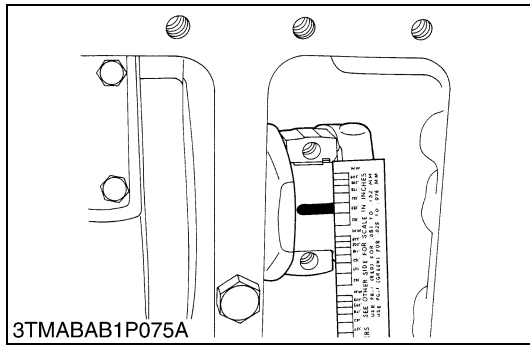

Oil Clearance between Crankpin and Crankpin Bearing

1. Clean the crankpin and crankpin bearing.
2. Put a strip of plastigage on the center of the crankpin.
3. Install the connecting rod cap and tighten the connecting rod screws to the specified torque, and remove the cap again.
4. Measure the amount of the flattening with the scale, and get the oil clearance.
5. If the oil clearance exceeds the allowable limit, replace the crankpin bearing.
6. If the same size bearing is useless because of the crankpin wear, replace it with an undersize one referring to the table and figure.

NOTE

- Never insert the plastigage into the crankpin oil hole.
- Be sure not to move the crankshaft while the connecting rod screws are tightened.

Oil clearance between crankpin and crankpin bearing	Factory spec.	0.020 to 0.051mm 0.00079 to 0.00201 in.
	Allowable limit	0.15 mm 0.0059 in.

Crankpin O.D.	Factory spec.	33.959 to 33.975 mm 1.33697 to 1.33760 in.
Crankpin bearing I.D.	Factory spec.	33.995 to 34.010 mm 1.33839 to 1.33898 in.

(Reference)

- Undersize crankpin bearing

Undersize	Bearing	Code Number	Marking
0.2 mm 0.008 in.	Crankpin bearing 02	15861-22970	020 US
0.4 mm 0.016 in.	Crankpin bearing 04	15861-20980	040 US

- Undersize dimensions of crankpin

Undersize	0.2 mm 0.008 in.	0.4 mm 0.016 in.
Dimension A	2.3 to 2.7 mm radius 0.091 to 0.106 in. radius	2.3 to 2.7 mm radius 0.091 to 0.106 in. radius
*Dimension B	1.0 to 1.5 mm relief 0.0394 to 0.0591 in. relief	1.0 to 1.5 mm relief 0.0394 to 0.0591 in. relief
Dimension C	33.759 to 33.775 mm dia. 1.32910 to 1.32973 in. dia.	33.559 to 33.575 mm dia. 1.32122 to 1.32185 in. dia.

(0.8S)

The crankpin must be fine-finished to higher than ∇∇∇∇.
 *Holes to be de-burred and edges rounded with 1.0 to 1.5 mm (0.0394 to 0.0591 in.) relief.

W11625390

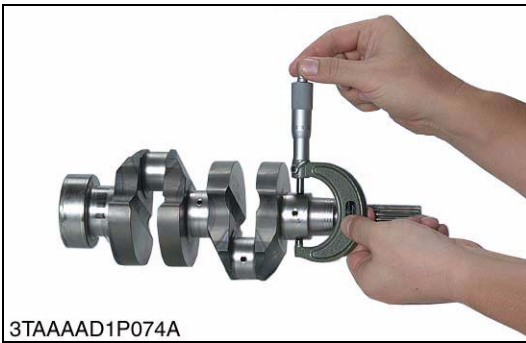

3TAAAD1P074A



3EEACAA1P012A

Oil Clearance between Crankshaft Journal and Crankshaft Bearing 1

1. Measure the O.D. of the crankshaft front journal with an outside micrometer.
2. Measure the I.D. of the crankshaft bearing 1 with an inside micrometer, and calculate the oil clearance.
3. If the oil clearance exceeds the allowable limit, replace the crankshaft bearing 1.
4. If the same size bearing is useless because of the crankshaft journal wear, replace it with an undersize one referring to the table and the figure.

Oil Clearance between crankshaft journal and crankshaft bearing 1	Factory spec.	0.034 to 0.106 mm 0.00134 to 0.00417 in.
	Allowable limit	0.20 mm 0.0079 in.

Crankshaft journal O.D.	Factory spec.	Z482-E2B D662-E2B D722-E2B D782-E2B	39.934 to 39.950 mm 1.57221 to 1.57284 in.
		Z602-E2B D902-E2B	43.934 to 43.950 mm 1.72968 to 1.73031 in.
Crankshaft bearing 1 I.D.	Factory spec.	Z482-E2B D662-E2B D722-E2B D782-E2B	39.984 to 40.040 mm 1.57417 to 1.57638 in.
		Z602-E2B D902-E2B	43.984 to 44.040 mm 1.73165 to 1.73386 in.

W10323470

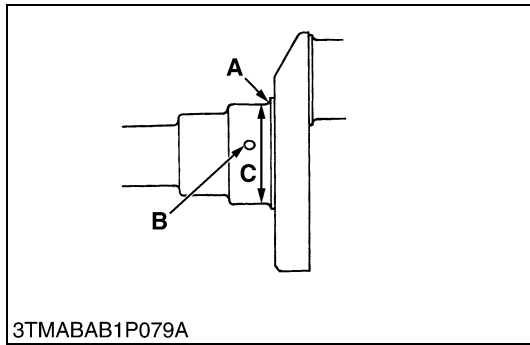

3TMABAB1P079A

Oil Clearance between Crankshaft Journal and Crankshaft Bearing 1 (Continued)

(Reference)

- Undersize crankshaft bearing 1

Undersize	Models	Bearing	Code Number	Marking
0.2 mm 0.008 in.	Z482-E2B D662-E2B D722-E2B D782-E2B	Crankshaft bearing 1 02	15861-23910	020 US
	Z602-E2B D902-E2B		1G460-23910	
0.4 mm 0.016 in.	Z482-E2B D662-E2B D722-E2B D782-E2B	Crankshaft bearing 1 04	15861-23920	040 US
	Z602-E2B D902-E2B		1G460-23920	

- Undersize dimensions of crankshaft journal

Undersize	Models	0.2 mm 0.008 in.	0.4 mm 0.016 in.
Dimension A	All models	1.8 to 2.2 mm radius 0.071 to 0.087 in. radius	1.8 to 2.2 mm radius 0.071 to 0.087 in. radius
*Dimension B	All models	1.0 to 1.5 mm relief 0.0394 to 0.0591 in. relief	1.0 to 1.5 mm relief 0.0394 to 0.0591 in. relief
Dimension C	Z482-E2B D662-E2B D722-E2B D782-E2B	39.734 to 39.750 mm dia. 1.56433 to 1.56496 in. dia.	39.534 to 39.550 mm dia. 1.55646 to 1.55709 in. dia.
	Z602-E2B D902-E2B	43.734 to 43.750 mm dia. 1.72181 to 1.72244 in. dia.	43.534 to 43.550 mm dia. 1.71394 to 1.71457 in. dia.

(0.8S)
The crankshaft journal must be fine-finished to higher than ∇∇∇∇.
*Holes to be de-burred and edges rounded with 1.0 to 1.5 mm (0.0394 to 0.0591 in.) relief.

W1044484

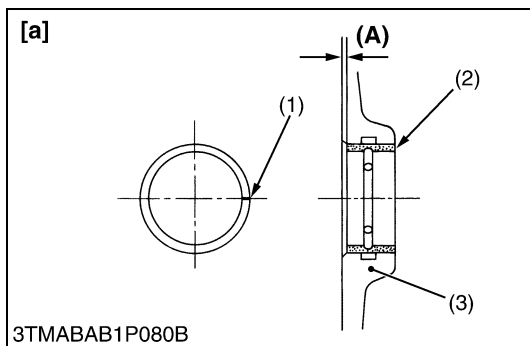

3TMABAB1P080B

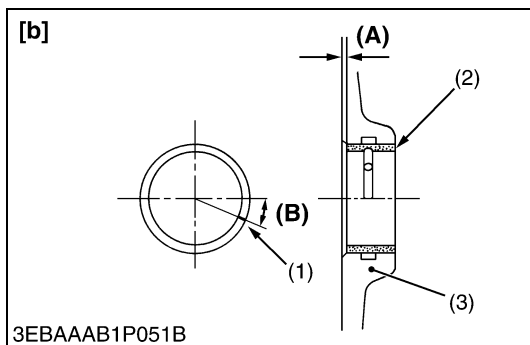

3EBAAAB1P051B

Replacing Crankshaft Bearing 1

(When removing)

1. Press out the used crankshaft bearing 1 using a crankshaft bearing 1 replacing tool. (Refer to "SPECIAL TOOLS".)

(When installing)

1. Clean a new crankshaft bearing 1 and crankshaft journal bore, and apply engine oil to them.
2. Using a crankshaft bearing 1 replacing tool, press in a new bearing 1 (2) so that its seam (1) directs toward the exhaust manifold side. (See figure.)

Dimension (A)	Factory spec.	0.0 to 0.3 mm 0.0 to 0.0118 in.
---------------	---------------	------------------------------------

- (1) Seam
 - (2) Crankshaft Bearing 1
 - (3) Cylinder Block
- [a] Z482-E2B, D662-E2B, D722-E2B, D782-E2B**
[b] Z602-E2B, D902-E2B

(A) Dimension
(B) 0.366 rad (21 °)

W10342000

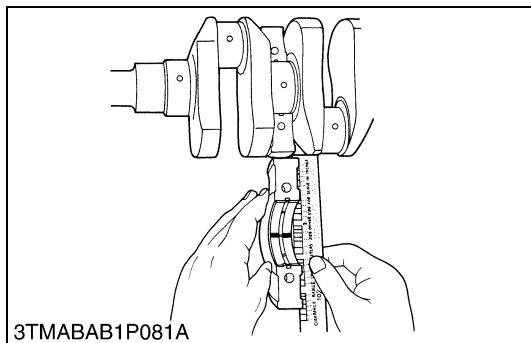

Oil Clearance between Crankshaft Journal and Crankshaft Bearing 2 and Crankshaft Bearing 3

1. Put a strip of plastigage on the center of the journal.
2. Install the bearing case and tighten the bearing case screws 1 to the specified torque, and remove the bearing case again.
3. Measure the amount of the flattening with the scale, and get the oil clearance.
4. If the oil clearance exceeds the allowable limit, replace the crankshaft bearing 2 (crankshaft bearing 3).
5. If the same size bearing is useless because of the crankshaft journal wear, replace it with an undersize one referring to the table and figure.

■ NOTE

- **Be sure not to move the crankshaft while the bearing case screws are tightened.**

Oil clearance between crankshaft journal and crankshaft bearing 2 (crankshaft bearing 3)	Factory spec.	0.028 to 0.059 mm 0.00110 to 0.00232 in.
	Allowable limit	0.20 mm 0.0079 in.

Crankshaft journal O.D. (Flywheel side)	Factory spec.	43.934 to 43.950 mm 1.72968 to 1.73031 in.
Crankshaft bearing 2 I.D.	Factory spec.	43.978 to 43.993 mm 1.73142 to 1.73201 in.

Crankshaft journal O.D. (Intermediate)	Factory spec.	Z482-E2B D662-E2B D722-E2B D782-E2B	39.934 to 39.950 mm 1.57221 to 1.57284 in.
		Z602-E2B D902-E2B	43.934 to 43.950 mm 1.72968 to 1.73031 in.
Crankshaft bearing 3 I.D.	Factory spec.	Z482-E2B D662-E2B D722-E2B D782-E2B	39.978 to 39.993 mm 1.57394 to 1.57453 in.
		Z602-E2B D902-E2B	43.978 to 43.993 mm 1.73142 to 1.73201 in.

W10344030

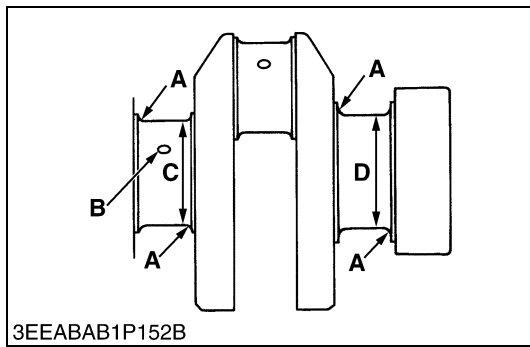

Oil Clearance between Crankshaft Journal and Crankshaft Bearing 2 and Crankshaft Bearing 3 (Continued)

(Reference)

- Undersize crankshaft bearing 2 and 3 (0.2 mm (0.008 in.))

Models	Bearing	Code Number	Marking
Z482-E2B D662-E2B D722-E2B D782-E2B	Crankshaft bearing 2 02	15694-23930	020 US
	Crankshaft bearing 3 02	15861-23860	
Z602-E2B D902-E2B	Crankshaft bearing 2 02	1G460-23930	020 US
	Crankshaft bearing 3 02	1G460-23940	

- Undersize crankshaft bearing 2 and 3 (0.4 mm (0.016 in.))

Models	Bearing	Code Number	Marking
Z482-E2B D662-E2B D722-E2B D782-E2B	Crankshaft bearing 2 04	15694-23940	040 US
	Crankshaft bearing 3 04	15861-23871	
Z602-E2B D902-E2B	Crankshaft bearing 2 04	1G460-23950	040 US
	Crankshaft bearing 3 04	1G460-23960	

- Undersize dimensions of crankshaft journal

Undersize	Models	0.2 mm 0.008 in.	0.4 mm 0.016 in.
Dimension A	All models	1.8 to 2.2 mm radius 0.071 to 0.087 in. radius	1.8 to 2.2 mm radius 0.071 to 0.087 in. radius
*Dimension B	All models	1.0 to 1.5 mm relief 0.0394 to 0.0591 in. relief	1.0 to 1.5 mm relief 0.0394 to 0.0591 in. relief
Dimension C	Z482-E2B D662-E2B D722-E2B D782-E2B	39.734 to 39.750 mm dia. 1.56433 to 1.56496 in. dia.	39.534 to 39.550 mm dia. 1.55646 to 1.55709 in. dia.
	Z602-E2B D902-E2B	43.734 to 43.750 mm dia. 1.72181 to 1.72244 in. dia.	43.534 to 43.550 mm dia. 1.71394 to 1.71457 in. dia.
Dimension D	All models	43.734 to 43.750 mm dia. 1.72181 to 1.72244 in. dia.	43.534 to 43.550 mm dia. 1.71394 to 1.71457 in. dia.

(0.8S)

The crankshaft journal must be fine-finished to higher than ∇∇∇∇.

*Holes to be de-burred and edges rounded with 1.0 to 1.5 mm (0.0394 to 0.0591 in.) relief.

W1047088

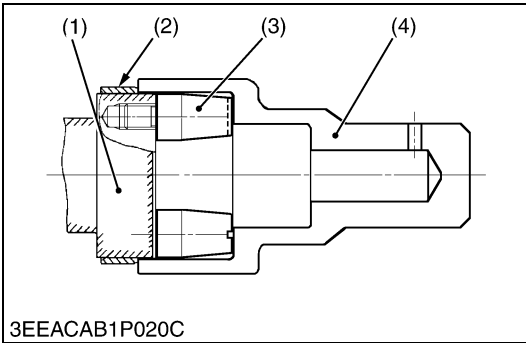
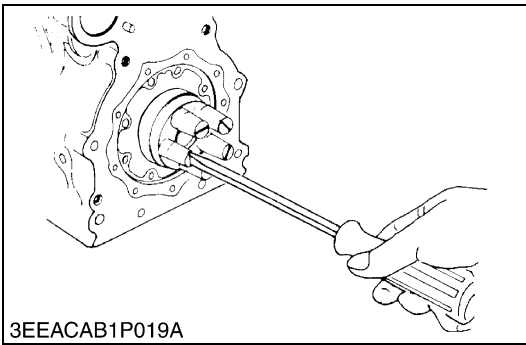

Replacing Crankshaft Sleeve (Z482-E2B, D662-E2B, D722-E2B, D782-E2B)

1. Remove the used crankshaft sleeve (2).
2. Set the sleeve guide (3) to the crankshaft (1).
3. Heat a new sleeve to a temperature between 150 and 200 °C (302 and 392 °F), and fix the sleeve to the crankshaft as shown in figure.
4. Press fit the sleeve using the auxiliary socket for pushing (4). (Refer to “SPECIAL TOOLS”.)

■ **NOTE**

- Mount the sleeve with its largely chamfered surface facing outward.
- Should heating is not enough, a sleeve might stop halfway, so careful.

- | | |
|-----------------------|----------------------------------|
| (1) Crankshaft | (3) Sleeve Guide |
| (2) Crankshaft Sleeve | (4) Auxiliary Socket for Pushing |

W1048540

(5) Cylinder



Cylinder Wear

1. Measure the cylinder liner I.D. at the six positions (see figure) with a cylinder gauge to find the maximum and minimum I.D.'s.
2. Get the difference (Maximum wear) between the maximum and the minimum I.D.'s.
3. If the wear exceeds the allowable limit, bore and hone to the oversize dimension. (Refer to “Correcting Cylinder”.)
4. Visually check the cylinder wall for scratches. If deep scratches are found, the cylinder should be bored. (Refer to “Correcting Cylinder”.)

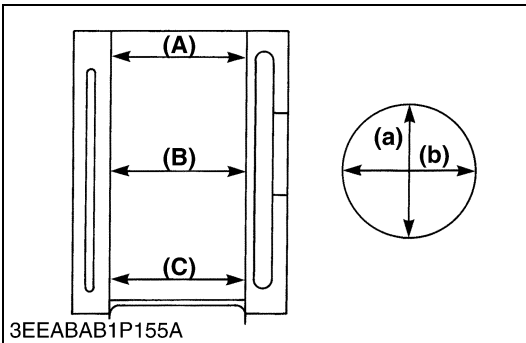

Cylinder liner I.D.	Factory spec.	D662-E2B	64.000 to 64.019 mm 2.51968 to 2.52043 in.
		Z482-E2B D722-E2B D782-E2B	67.000 to 67.019 mm 2.63779 to 2.63854 in.
		Z602-E2B D902-E2B	72.000 to 72.019 mm 2.83464 to 2.83539 in.
	Allowable limit	D662-E2B	64.150 mm 2.52559 in.
		Z482-E2B D722-E2B D782-E2B	67.150 mm 2.64370 in.
		Z602-E2B D902-E2B	72.150 mm 2.84055 in.

- (A) Top
- (B) Middle
- (C) Bottom (Skirt)

- (a) Right-angled to Piston Pin
- (b) Piston Pin Direction

W10360060

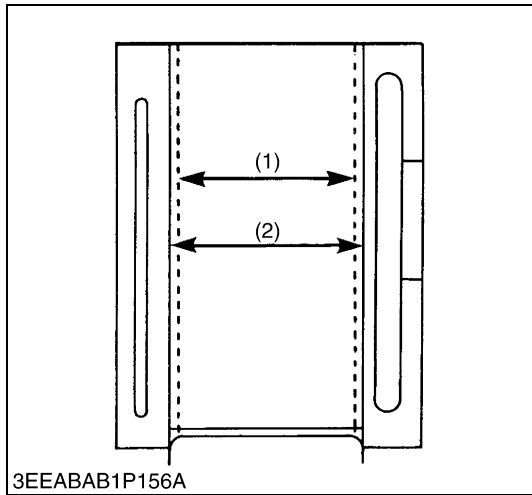

Correcting Cylinder (Oversize)

1. When the cylinder is worn beyond the allowable limit, bore and hone it to the specified dimension.

Cylinder liner I.D.	Factory spec.	D662-E2B	64.250 to 64.269 mm 2.52953 to 2.53027 in.
		Z482-E2B D722-E2B D782-E2B	67.250 to 67.269 mm 2.64764 to 2.64839 in.
		Z602-E2B D902-E2B	72.250 to 72.269 mm 2.84449 to 2.84524 in.
	Allowable limit	D662-E2B	64.400 mm 2.53543 in.
		Z482-E2B D722-E2B D782-E2B	67.400 mm 2.65354 in.
		Z602-E2B D902-E2B	72.400 mm 2.85040 in.
Finishing	Hone to 2.2 to 3.0 μmRz (0.000087 to 0.00012 in.Rz) $\nabla\nabla\nabla$.		

2. Replace the piston and piston rings with oversize ones.
Oversize : 0.25 mm (0.0098 in.)
Marking : 025

NOTE

- When the oversize cylinder is worn beyond the allowable limit, replace the cylinder block with a new one.

(1) Cylinder I.D. (Before Correction) (2) Cylinder I.D. [Oversize]

W10367470

(6) Oil Pump



Rotor Lobe Clearance

1. Measure the clearance between lobes of the inner rotor and the outer rotor with a thickness gauge.
2. If the clearance exceeds the factory specifications, replace the oil pump rotor assembly.

Rotor lobe clearance	Factory spec.	0.03 to 0.14 mm 0.0012 to 0.0055 in.
----------------------	---------------	---

W10378950

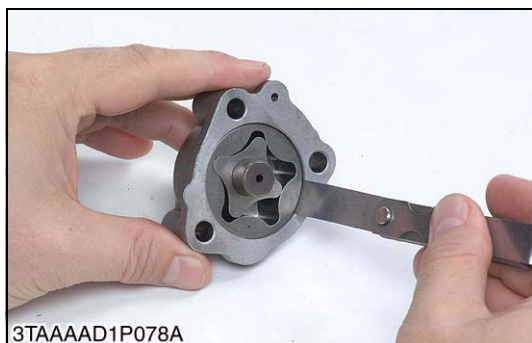

Clearance between Outer Rotor and Pump Body

1. Measure the clearance between the outer rotor and the pump body with a thickness gauge.
2. If the clearance exceeds the factory specifications, replace the oil pump rotor assembly.

Clearance between outer rotor and pump body	Factory spec.	0.07 to 0.15 mm 0.0028 to 0.0059 in.
---	---------------	---

W10381420

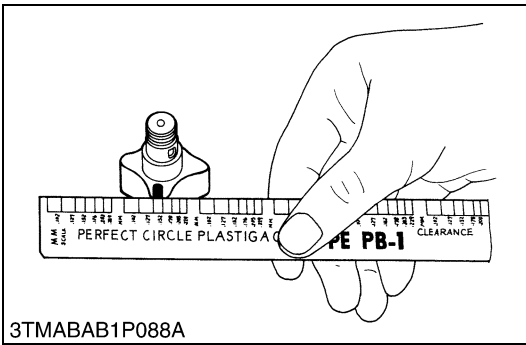

Clearance between Rotor and Cover

1. Put a strip of plastigage onto the rotor face with grease.
2. Install the cover and tighten the screws.
3. Remove the cover carefully, and measure the amount of the flattening with the scale and get the clearance.
4. If the clearance exceeds the factory specifications, replace oil pump rotor assembly.

Clearance between rotor and cover	Factory spec.	0.075 to 0.135 mm 0.00295 to 0.00531 in.
-----------------------------------	---------------	---

W10382660

(7) Starter

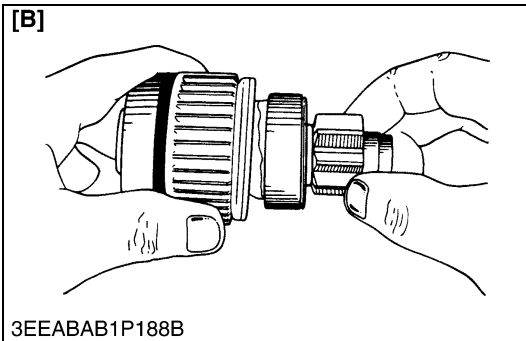
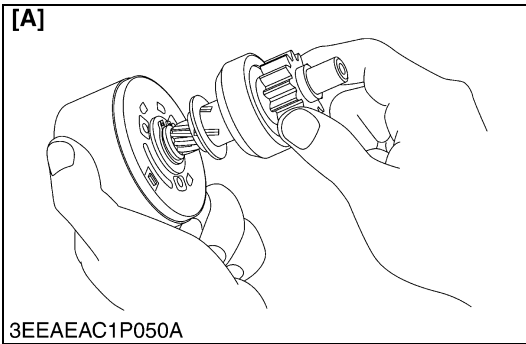

Overrunning Clutch

1. Check the pinion and if worn or damaged, replace the clutch assembly.
2. Check that the pinion turns freely and smoothly in the overrunning direction and does not slip in the cranking direction.
3. If the pinion slips or does not turn in both directions, replace the overrunning clutch assembly.

NOTE

- Do not wash off the grease in the overrunning clutch with the chemicals or oils.

[A] Electromagnetic Drive Type

[B] Planetary Gear Reduction Type

W1156799

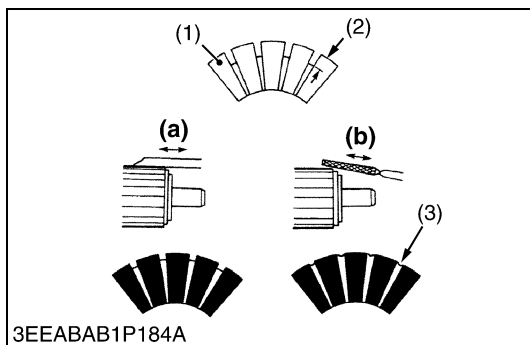
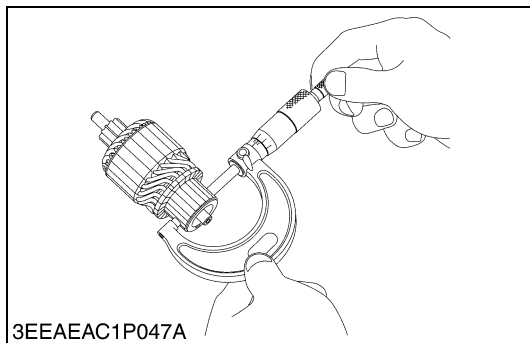
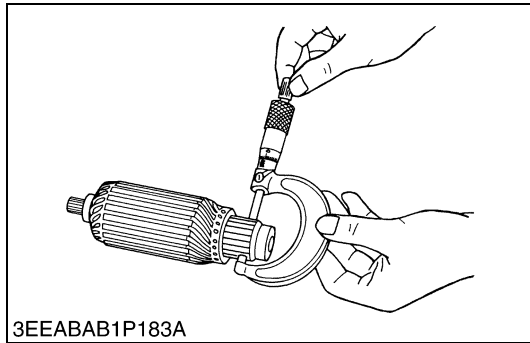
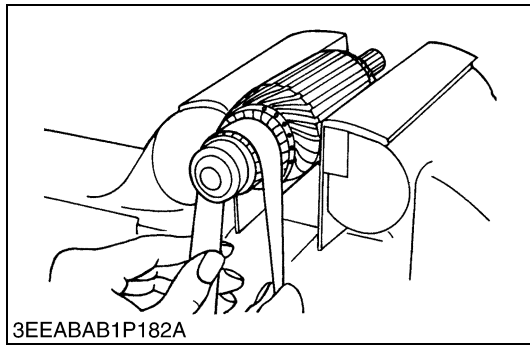

Commutator and Mica

1. Check the contact of the commutator for wear, and grind the commutator with emery paper if it is slightly worn.
2. Measure the commutator O.D. with an outside micrometer at several points.
3. If the minimum O.D. is less than the allowable limit, replace the armature.
4. If the difference of the O.D.'s exceeds the allowable limit, correct the commutator on a lathe to the factory specification.
5. Measure the mica undercut.
6. If the undercut is less than the allowable limit, correct it with a saw blade and chamfer the segment edges.

Commutator O.D.	Factory spec.	Electromagnetic drive type	28.0 mm 1.102 in.
		Planetary gear reduction type	30.0 mm 1.181 in.
	Allowable limit	Electromagnetic drive type	27.0 mm 1.063 in.
		Planetary gear reduction type	29.0 mm 1.142 in.

Difference of O.D.'s	Factory spec.	Electromagnetic drive type	Less than 0.05 mm 0.002 in.
		Planetary gear reduction type	Less than 0.02 mm 0.0008 in.
	Allowable limit	Electromagnetic drive type	0.4 mm 0.016 in.
		Planetary gear reduction type	0.05 mm 0.0020 in.

Mica under cut	Factory spec.	0.50 to 0.80 mm 0.0197 to 0.0315 in.
	Allowable limit	0.20 mm 0.0079 in.

- (1) Segment
- (2) Depth of Mica
- (3) Mica

- (a) Correct
- (b) Incorrect

W1155802

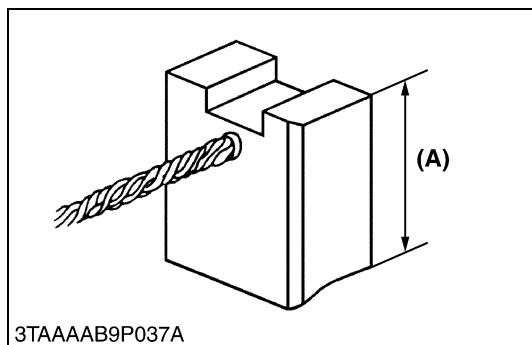

Brush Wear

1. If the connect face of the brush is dirty or dusty, clean it with emery paper.
2. Measure the brush length **(A)** with vernier caliper.
3. If the length is than the allowable limit, replace the yoke assembly and brush holder.

Brush length A	Factory spec.	Electromagnetic drive type	16.0 mm 0.630 in.
		Planetary gear reduction type	14.0 mm 0.551 in.
Allowable limit	Allowable limit	Electromagnetic drive type	10.5 mm 0.413 in.
		Planetary gear reduction type	9.0 mm 0.354 in.

W1156360

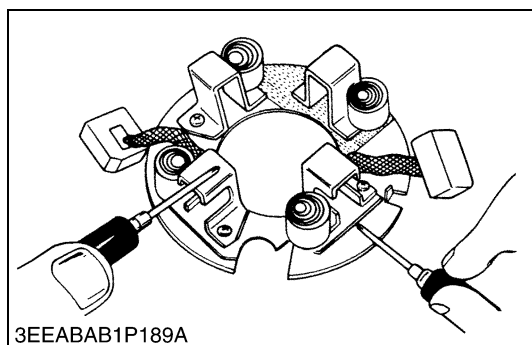

Brush Holder

1. Check the continuity across the brush holder and the holder support with a circuit tester.
2. If it conducts, replace the brush holder.

W1156895

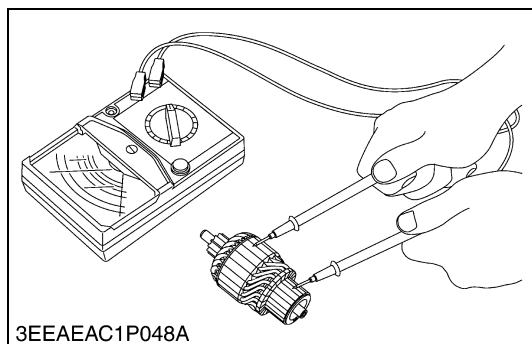

Armature Coil

1. Check the continuity across the commutator and armature coil core with resistance range of circuit tester.
2. If it conducts, replace the armature.
3. Check the continuity across the segments of the commutator with resistance range of circuit tester.
4. If it does not conduct, replace the armature.

W1156507

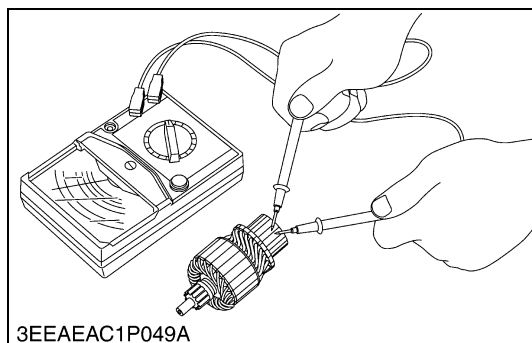

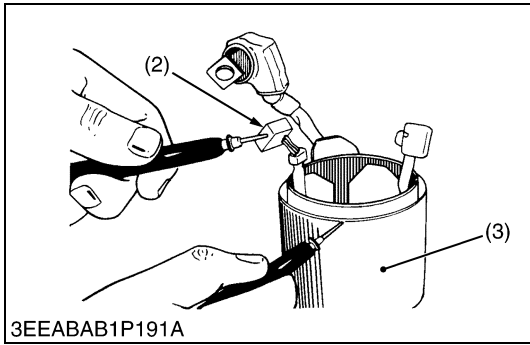
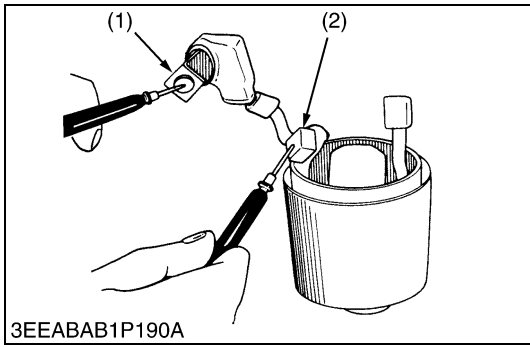

Field Coil

1. Check the continuity across the lead (1) and brush (2) with a circuit tester.
2. If it dose not conduct, replace the yoke assembly.
3. Check the continuity across the brush (2) and yoke (3) with a circuit tester.
4. If it conducts, replace the yoke assembly.

- (1) Lead
- (2) Bush
- (3) Yoke

W1156968

(8) Alternator

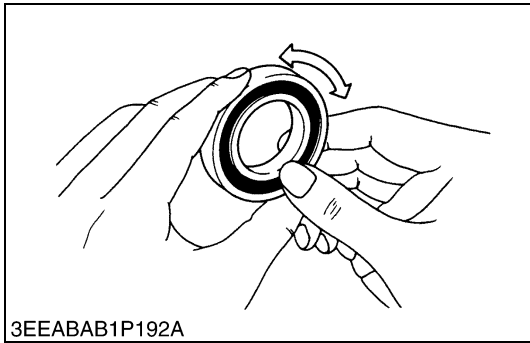

Bearing

1. Check the bearing for smooth rotation.
2. If it does not rotate smoothly, replace it.

W1019790

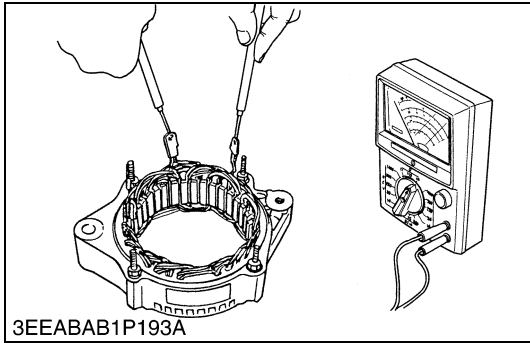

Stator

1. Measure the resistance across each lead of the stator coil with resistance range of circuit tester.
2. If the measurement is not within factory specification, replace it.
3. Check the continuity across each stator coil lead and core with resistance range of circuit tester.
4. If infinity is not indicated, replace it.

Resistance	Factory spec.	Less than 1.0 Ω
------------	---------------	-----------------

W1019964

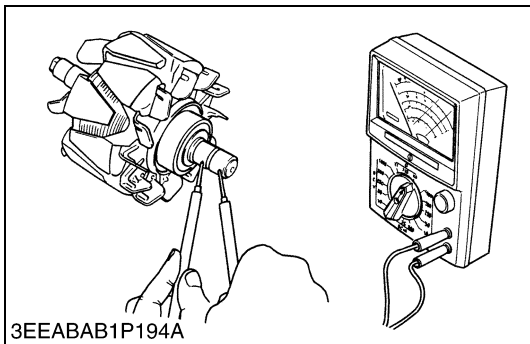

Rotor

1. Measure the resistance across the slip rings.
2. If the resistance is not the factory specification, replace it.
3. Check the continuity across the slip ring and core with resistance range of circuit tester.
4. If infinity is not indicated, replace it.

Resistance	Factory spec.	2.9 Ω
------------	---------------	-------

W1020094

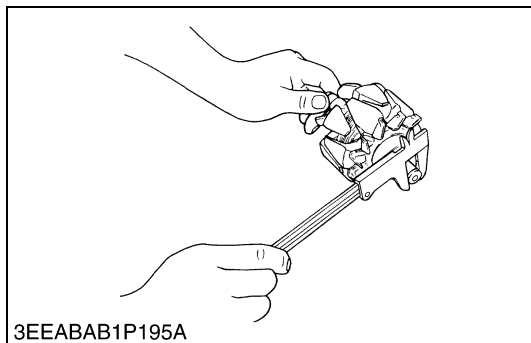
**Slip Ring**

1. Check the slip ring for score.
2. If scored, correct with an emery paper or on a lathe.
3. Measure the O.D. of slip ring with vernier calipers.
4. If the measurement is less than the allowable limit, replace it.

Slip ring O.D.	Factory spec.	14.4 mm 0.567 in.
	Allowable limit	14.0 mm 0.551 in.

W1020208

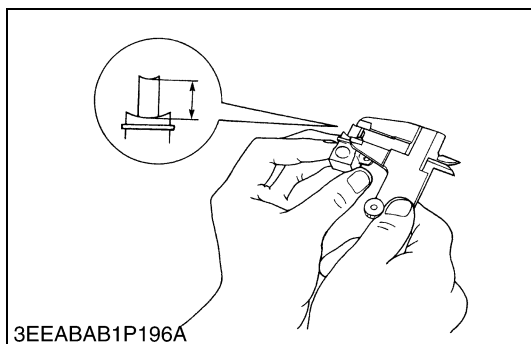
**Brush Wear**

1. Measure the brush length with vernier calipers.
2. If the measurement is less than allowable limit, replace it.
3. Make sure that the brush moves smoothly.
4. If the brush is defective, replace it.

Brush length	Factory spec.	10.5 mm 0.413 in.
	Allowable limit	8.4 mm 0.331 in.

W1020329

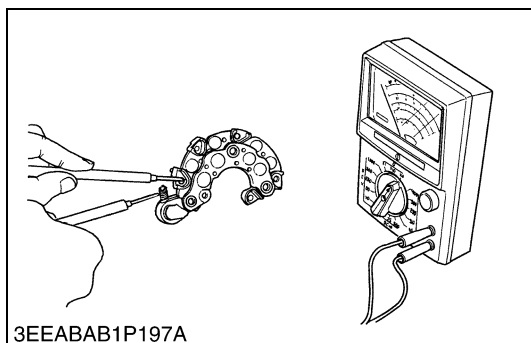
**Rectifier**

1. Check the continuity across each diode of rectifier with resistance range of circuit tester.
2. The rectifier is normal if the diode in the rectifier conducts in one direction and does not conduct in the reverse direction.

W1020452

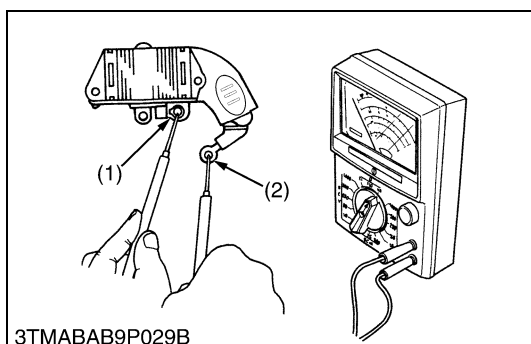
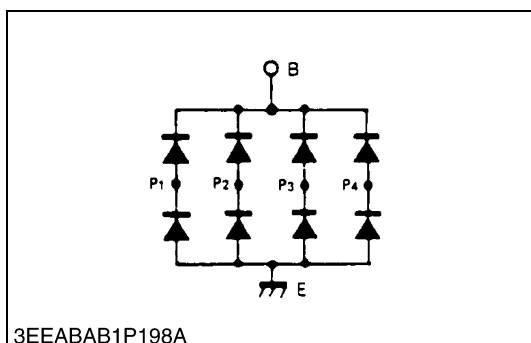
**IC Regulator**

1. Check the continuity across the **B** terminal (2) and the **F** terminal (1) of IC regulator with resistance range of circuit tester.
2. The IC regulator is normal if the conducts in one direction and does not conduct in the reverse direction.

(1) **F** Terminal(2) **B** Terminal

W1020645

EDITOR:

KUBOTA FARM & INDUSTRIAL MACHINERY SERVICE, LTD.

64, ISHIZU-KITAMACHI, SAKAI-KU, SAKAI-CITY, OSAKA, 590-0823, JAPAN

PHONE : (81)72-241-1129

FAX : (81)72-245-2484

E-mail : ksos-pub@kubota.co.jp
