

WG Series

SPARK IGNITED ENGINE

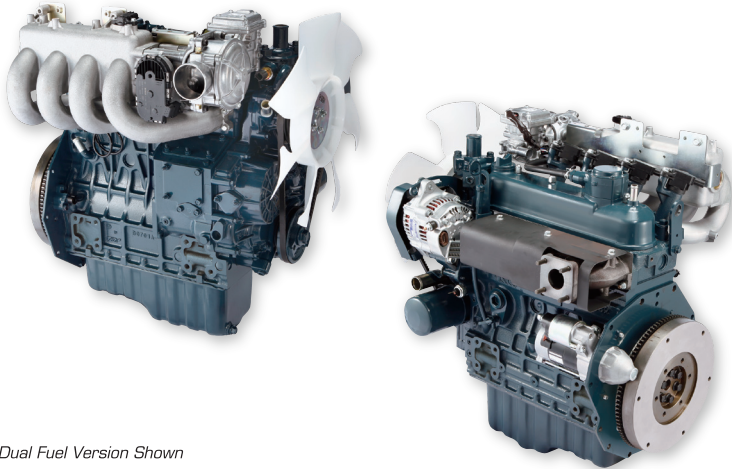

Dual Fuel Version Shown

PERFORMANCE CURVE

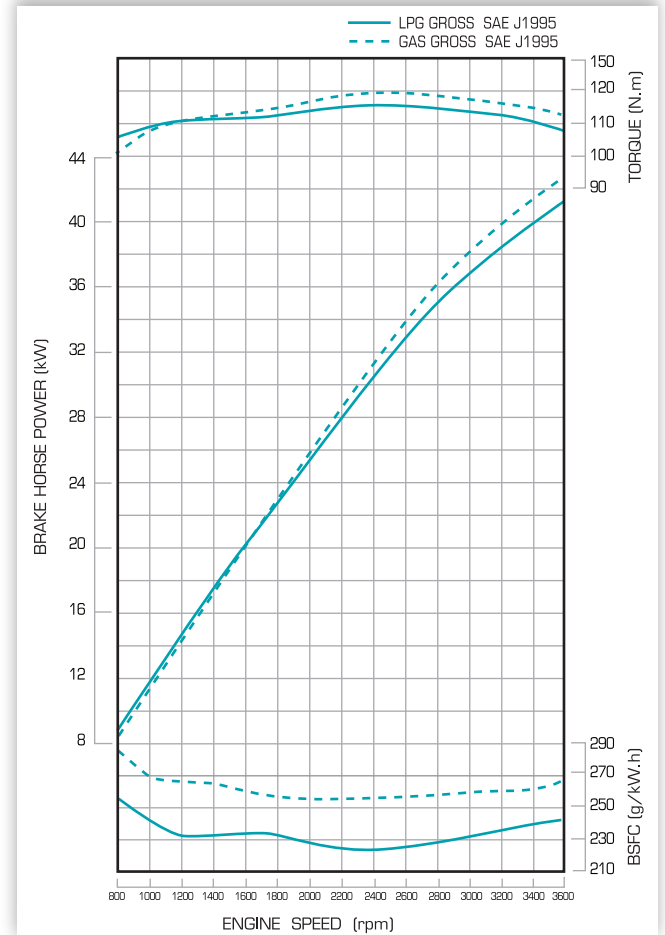

FEATURES & BENEFITS

- Based on industrial diesel engine platform
- Kubota is the Manufacturer of Record (MOR)
- Very low vibration
- Electronic fuel injection
- Throttle control - electronic drive by wire
- 3-Way Catalytic Converter
- Geardrive valve train - no belts or chains
- Diagnostic port
- Wire harness / ECU factory installed
- Hot tested at factory
- Full CAN capabilities - SAE J1939
- Same footprint as with V1505 diesel
- Similar performance to turbo diesel
- Exceptionally quiet

SPECIFICATIONS

Model	WG1605	Cooling System	High Capacity Liquid
Engine Type	Vertical liquid cooled 4 cycle	Direction of Rotation Rev.	Counter-clockwise (view from flywheel)
Number of Cylinders	4 in-line	Oil Pan Capacity L (gal)	6.0 (1.59)
Bore x Stroke mm (in)	79 x 78.4 (3.11 x 3.09)	Starter Capacity V-kW	12V - 1.0 kW
Displacement L	1.537	Alternator Capacity V-A	12V-40A
Ignition System	Coil on plug	Length mm (in)	591.3 (23.3)
Intake System	Naturally Aspirated	Width mm (in)	478.7 (18.8)
Compression Ratio	9.1:1 (all fuels)	Height mm (in)	652.3 (25.7)
Governor Type	Electronic	Dry Weight kg (lbs)	120 (264.6)

WG1605 OUTPUT		kW (HP)					
		50 Hz @ 1500 RPM		60 Hz @ 1800 RPM		3000 RPM	3600 RPM
		Stand-by	Continuous	Stand-by	Continuous	Gross Int.	Gross Int.
FUEL TYPE	GASOLINE	15.9 (21.3)	14.5 (19.4)	19.2 (25.7)	17.5 (23.5)	37.0 (49.6)	42.5 (57.0)
	LPG					36.0 (48.3)	41.0 (55.0)

OPTIONS

- Radiator
- Air Cleaner
- Flywheel: SAE Short #6 1/2
- Flywheel Housing: SAE Short #5
- Some V1505 diesel options are available for WG1605

EMISSION CERTIFICATIONS

- EPA Non-Road LSI Tier 2 Certified
- CARB Off-Road LSI Tier 3 Certified

WARRANTY INFORMATION

Engine Warranty:

- 2 years or 2000 hours whichever occurs first

Engine Major Components Warranty:

- 3 years or 3000 hours whichever occurs first, parts only

Emission Warranty (covers emission parts only):

- 3 years or 2500 hours whichever occurs first

DIMENSIONS mm(in)

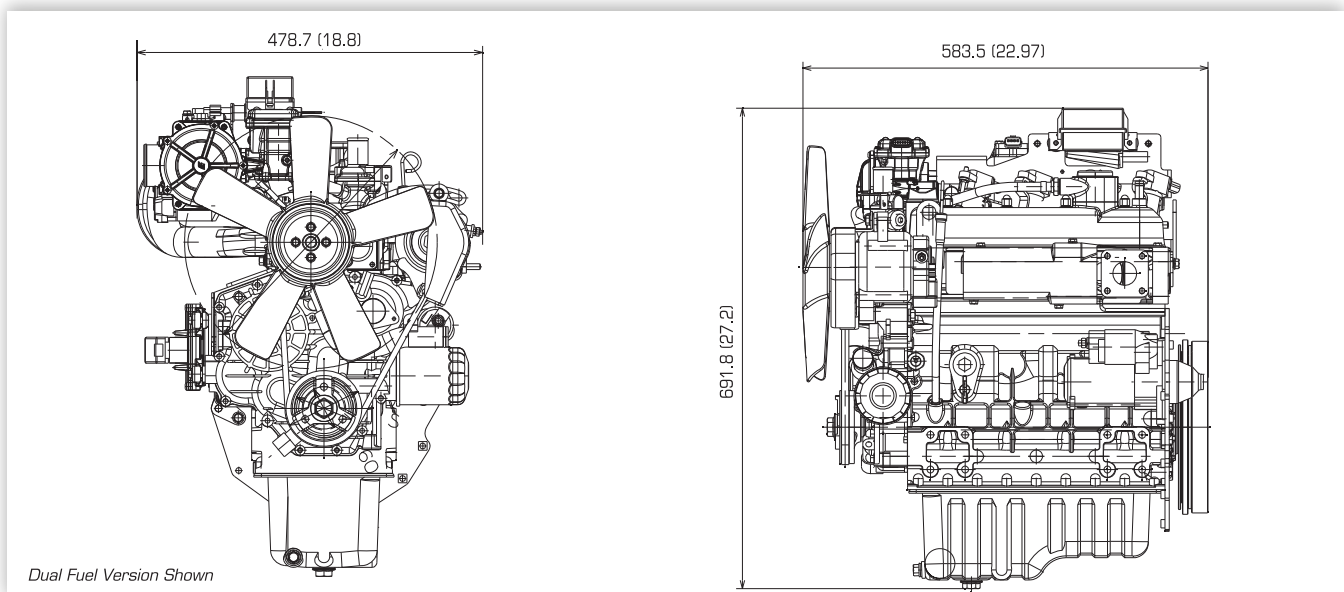

Dual Fuel Version Shown

KUBOTA ENGINE AMERICA

505 Scheller Road Lincolnshire, IL 60069
 Phone: 847-955-2500 Fax: 847-955-2501
www.kubotaengine.com

KUBOTA CANADA, LTD

5900 14th Avenue, Markham, Ontario L3S 4K4
 Phone: 905-294-7477 Fax: 905-294-1554

