

REV	ECH #	DATE	DESCRIPTION OF CHANGE-IS (WAS)	BY:
Ⓐ	4910	6/11/94	RELEASED FOR PRODUCTION	E.J.

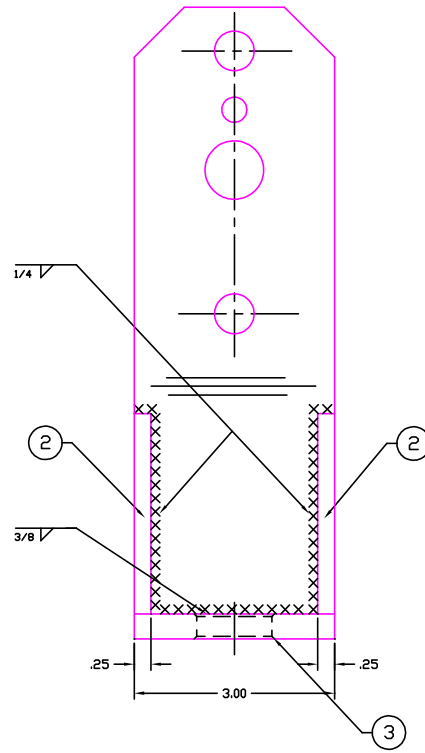
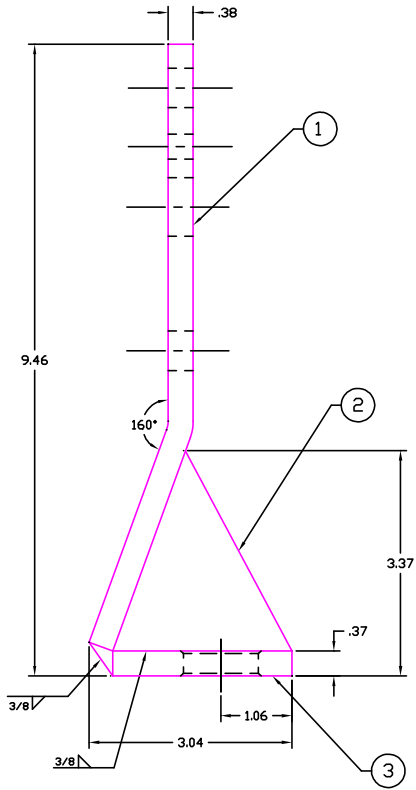

315501 A

BILL OF MATERIAL			
ITEM	PART #	DESCRIPTION	QTY
①	315502	MNT-WD KBTA ENGINE OUTER	1
②	315503	MNT-GUSSET KBTA ENGINE OUTER	2
③	315504	MNT-WLD BOTTOM KBTA ENGINE OUTER	1

<small>THIS DOCUMENT AND ALL INFORMATION CONTAINED IN THIS DOCUMENT ARE CONFIDENTIAL AND PROPRIETARY TO AAR POWERBOSS, INC. (AAR). UNAUTHORIZED REPRODUCTION OR USE THEREOF IS PROHIBITED. THIS DOCUMENT OR ANY PART HEREOF OR ANY INFORMATION CONTAINED HEREIN, MAY NOT BE REPRODUCED, REPRODUCED, OR DISCLOSED TO ANY PERSON FOR ANY PURPOSE EXCEPT AS SPECIFICALLY AUTHORIZED IN WRITING BY AAR. BY ACCEPTING THIS DOCUMENT, RECIPIENT AGREES TO COMPLY WITH THE FOREGOING AND TO RETURN THIS DOCUMENT TO AAR IMMEDIATELY UPON REQUEST. UNPUBLISHED—ALL RIGHTS RESERVED UNDER COPYRIGHT LAWS.</small>		SOURCE: P/N: SEE BDM MATL: FINISH: MAROON UNSPECIFIED TOLERANCES: .X .1 ANGLAR: .XX .03 X 1° .XXX .010 X .5°	AAR PowerBoss Aberdeen, North Carolina 28315 PHONE (919) 944-2105 FAX (919) 944-7409 CAD BY: E.J. SMITH DATE: 6/10/94 DESCRIPTION ASSY-WD MNT KBTA ENG OUTER PART NO. 315501 REV LEV A SHT NO. 1 OF 1
DES. ENG: ENG. REL:			